



Installation and Operation Manual



505 Digital Governor for Steam Turbines with Single or Split-Range Actuators

Volume 1

Manual 85017V1B



WARNING

Read this entire manual and all other publications pertaining to the work to be performed before installing, operating, or servicing this equipment. Practice all plant and safety instructions and precautions. Failure to follow instructions can cause personal injury and/or property damage.

The engine, turbine, or other type of prime mover should be equipped with an overspeed shutdown device to protect against runaway or damage to the prime mover with possible personal injury, loss of life, or property damage.

The overspeed shutdown device must be totally independent of the prime mover control system. An overtemperature or overpressure shutdown device may also be needed for safety, as appropriate.



CAUTION

To prevent damage to a control system that uses an alternator or battery-charging device, make sure the charging device is turned off before disconnecting the battery from the system.

Electronic controls contain static-sensitive parts. Observe the following precautions to prevent damage to these parts.

- Discharge body static before handling the control (with power to the control turned off, contact a grounded surface and maintain contact while handling the control).
- Avoid all plastic, vinyl, and Styrofoam (except antistatic versions) around printed circuit boards.
- Do not touch the components or conductors on a printed circuit board with your hands or with conductive devices.



IMPORTANT DEFINITIONS

WARNING—indicates a potentially hazardous situation which, if not avoided, could result in death or serious injury.



CAUTION—indicates a potentially hazardous situation which, if not avoided, could result in damage to equipment.



NOTE—provides other helpful information that does not fall under the warning or caution categories.

Revisions—Text changes are indicated by a black line alongside the text.

Woodward Governor Company reserves the right to update any portion of this publication at any time. Information provided by Woodward Governor Company is believed to be correct and reliable. However, no responsibility is assumed by Woodward Governor Company unless otherwise expressly undertaken.

© Woodward 1997
All Rights Reserved

Contents

ELECTROSTATIC DISCHARGE AWARENESS	V
CHAPTER 1. GENERAL INFORMATION.....	1
Introduction.....	1
General Description.....	3
505 Inputs and Outputs	5
Control Overview	8
Speed Control.....	8
Auxiliary Control	8
Load Sharing Input	9
Cascade Control.....	9
Valve Limiter	10
Starting Features	10
Critical Speed Avoidance	11
Block Diagrams	11
Keypad and Display.....	14
Watchdog Timer/CPU Fault Control.....	16
CHAPTER 2. INSTALLATION PROCEDURES.....	17
Introduction.....	17
Mechanical Data and Hardware Installation.....	17
Communications Grounding and Shielding.....	33
CHAPTER 3. 505 CONTROL DESCRIPTION.....	35
Introduction.....	35
Turbine Start.....	35
Turbine Start Modes	37
Critical Speed Avoidance	40
Idle/Rated	41
Automatic Start Sequence.....	42
No Idle Programmed	45
Speed Control Overview	45
Speed PID Operational Modes.....	46
Cascade Control.....	58
Auxiliary Control	64
Remote Auxiliary Setpoint	68
Valve Limiter	70
Emergency Shutdown	70
Controlled Shutdown	71
Overspeed Test Function	72
Local/Remote Function	73
Function Keys.....	74
Relays.....	74
CHAPTER 4. CONFIGURATION PROCEDURES	77
Program Architecture	77
Programming the 505.....	78
Exiting the Program Mode.....	101
Valve/Actuator Calibration & Test	105
Calibration/Stroking Procedure	106
Calibration/Stroking Procedure	108

Contents

CHAPTER 5. 505 OPERATION.....	112
Run Mode Architecture.....	112
Keypad and Display.....	116
Run Mode Front Panel Keys	116
Starting Procedures.....	117
Speed Key Screens.....	118
Overspeed Test Function	122
F3 and F4 Keys	123
Limiter (LMTR) Key Screens	123
Actuator (ACTR) Key Screens	124
Control (CONT) Key Screens.....	125
Dynamics (DYN) Key Screens	127
Stop Key Screens.....	128
Auxiliary (Aux) Key Screens	128
Remote/Speed Bias (RMT) Key Screens.....	131
Unit Load (KW) Key Screens	134
Cascade (CAS) Key Screens	135
Alarms.....	137
Trips.....	138
Speed, Cascade, and Auxiliary Dynamics Adjustments	139
CHAPTER 6. COMMUNICATIONS.....	143
Modbus® * Communications.....	143
Port Adjustments	146
505 Control Modbus Addresses.....	146
Specific Address Information.....	157
CHAPTER 7. SERVICE OPTIONS.....	159
Product Service Options.....	159
Returning Equipment for Repair.....	160
Replacement Parts	161
How to Contact Woodward.....	161
Engineering Services.....	162
Technical Assistance.....	163
APPENDIX. 505 PROGRAM MODE WORKSHEETS	164

Illustrations and Tables

Figure 1-1. Typical Single or Dual Inlet Steam Turbine	3
Figure 1-2. Split Range or Admission Type of Turbine Configuration	3
Figure 1-3a. Overview of 505 Functionality.....	6
Figure 1-3b. Overview of 505 Functionality.....	7
Figure 1-4. Overview of 505 Functionality Notes	12
Figure 1-5. Single or Split-Range Turbine Configurations	13
Figure 1-6. Single or Split-Range Turbine Configurations	13
Figure 1-7. Single or Split-Range Turbine Configurations	14
Figure 1-8. 505 Key Pad and Display.....	14
Figure 2-1. 505 Control Layout (Standard Enclosure)	19
Figure 2-2. 505 Bulkhead-Mounted Enclosure.....	20
Figure 2-3. Jumper Options.....	21
Figure 2-4. Jumper Locations.....	21
Figure 2-5. CageClamp Terminal Blocks	23
Figure 2-6. Control Wiring Diagram	24
Figure 2-7. Representative 505 I/O Schematic	25
Figure 2-8. Fuse location.....	26
Figure 2-9. Shielded Wire Connections	27
Figure 2-10. Typical RS-232 Communications	32
Figure 2-11. Typical RS-422 Communications	32
Figure 2-12. Typical RS-485 Communications	33
Figure 2-13. Preferred Multipoint Wiring with a Separate Signal Ground Wire ...	33
Figure 2-14. Alternate Multipoint Wiring without a Separate Signal Ground Wire	34
Figure 3-1. Basic Control Overview.....	35
Figure 3-2. Manual Start Mode Example	38
Figure 3-3. Semiautomatic Start mode Example	39
Figure 3-4. Automatic Start Mode Example	40
Figure 3-5. Idle/Rated Start	42
Figure 3-6. Automatic Start Sequence	43
Figure 3-7. Speed Control Functional Diagram.....	46
Figure 3-8. Speed PID Control Modes	47
Figure 3-9. Frequency and Unit Load Relationship	49
Figure 3-10. Speed Relationships	51
Figure 3-11. Loadsharing Logic.....	57
Figure 3-12. Cascade Functional Diagram	59
Figure 3-13. Aux Control Overview	64
Figure 4-1. Basic Program Architecture	77
Figure 4-2. Initial 505 Program Mode Entry	78
Figure 4-3a. Program Mode Blocks	81
Figure 4-3b. Program Mode Blocks	82
Figure 4-3c. Program Mode Blocks.....	83
Figure 4-3d. Program Mode Blocks	84
Figure 4-4. Exiting the Program Mode	101
Figure 4-5. Stroke Actuator	110
Figure 4-6. Stroking Dual Actuators	111
Figure 5-1. Basic Program Architecture	112
Figure 5-2a. Overview of Run Mode	113
Figure 5-2b. Overview of Run Mode	114
Figure 5-3. 505 Keypad and Display	116
Figure 5-4. SPEED Key Screens	118
Figure 5-5. Direct Setpoint Entry	121
Figure 5-6. Overspeed Test Enable Key Screens.....	122
Figure 5-7. LMTR Key Screens.....	124
Figure 5-8. ACTR Key Screens.....	125

Illustrations and Tables

Figure 5-9. CONT Key Screens	126
Figure 5-10. DYN Key Screens	127
Figure 5-11. STOP Key Screens	128
Figure 5-12. AUX Key Screens	129
Figure 5-13. RMT Key Screens	132
Figure 5-14. KW Key Screens	134
Figure 5-15. CAS Key Screens	135
Figure 5-16. ALARM Screen	137
Figure 5-17. TRIP Screen.....	138
Figure 5-18. Typical Response to Load Change.....	142
Figure 6-1. ASCII/RTU Representation of 3.....	144
Figure 6-2. Modbus Frame Definition.....	145
Table 2-1. Jumper Options Chart	22
Table 3-1. On-Line/Off-Line Dynamics Selection	53
Table 3-2. Load Sharing Logic	58
Table 4-1. Actuator Driver Limits	106
Table 5-1. Overview of Run Mode.....	115
Table 5-2. Idle/Rated Messages	119
Table 5-3. Auto Start Messages.....	120
Table 5-4. Controlling Parameter Messages.....	126
Table 5-5. Auxiliary Messages (if using Aux enable)	130
Table 5-6. Auxiliary Messages (if using Aux as a limiter).....	130
Table 5-7. Remote AUX Messages.....	131
Table 5-8. Remote Speed Messages.....	132
Table 5-9. Control Messages	133
Table 5-10. Cascade Control Messages	136
Table 5-11. Remote Cascade Messages.....	137
Table 5-12. Alarm Messages	138
Table 5-13. Trip Messages.....	139
Table 6-1. ASCII vs RTU Modbus	144
Table 6-2. Modbus Function Codes	145
Table 6-3. Modbus Error Codes	146
Table 6-4. Maximum Modbus Discrete and Analog Values	147
Table 6-5. Boolean Write Addresses.....	148
Table 6-6. Boolean Read Addresses	150
Table 6-7. Analog Read Addresses	152
Table 7-8. Analog Write Addresses.....	152
Table 6-9. Last Turbine Trip Cause.....	153
Table 6-10. Control Status.....	153
Table 6-11. Analog Input Configuration.....	154
Table 6-12. Analog Output Configuration.....	154
Table 6-13. Relay Configuration.....	155
Table 6-14. Contact Input Configurations.....	156
Table 6-15. Units Configuration.....	156

Electrostatic Discharge Awareness

All electronic equipment is static-sensitive, some components more than others. To protect these components from static damage, you must take special precautions to minimize or eliminate electrostatic discharges.

Follow these precautions when working with or near the control.

1. Before doing maintenance on the electronic control, discharge the static electricity on your body to ground by touching and holding a grounded metal object (pipes, cabinets, equipment, etc.).
2. Avoid the build-up of static electricity on your body by not wearing clothing made of synthetic materials. Wear cotton or cotton-blend materials as much as possible because these do not store static electric charges as much as synthetics.
3. Keep plastic, vinyl, and Styrofoam materials (such as plastic or Styrofoam cups, cup holders, cigarette packages, cellophane wrappers, vinyl books or folders, plastic bottles, and plastic ash trays) away from the control, the modules, and the work area as much as possible.
4. Do not remove the printed circuit board (PCB) from the control cabinet unless absolutely necessary. If you must remove the PCB from the control cabinet, follow these precautions:
 - Do not touch any part of the PCB except the edges.
 - Do not touch the electrical conductors, the connectors, or the components with conductive devices or with your hands.
 - When replacing a PCB, keep the new PCB in the plastic antistatic protective bag it comes in until you are ready to install it. Immediately after removing the old PCB from the control cabinet, place it in the antistatic protective bag.



CAUTION

To prevent damage to electronic components caused by improper handling, read and observe the precautions in Woodward manual 82715, *Guide for Handling and Protection of Electronic Controls, Printed Circuit Boards, and Modules*.

Chapter 1.

General Information

Introduction

This manual describes the Woodward 505 Digital Governor for steam turbines. English versions are 9907-162, 9907-163, and 9907-164. The option charts below show the differences between the part numbers. Volume 1 of this manual provides installation instructions, describes the control, and explains the configuration (programming) and operating procedures. Volume 2 includes notes on applying the control to specific applications, Service mode information, and 505 hardware specifications. This manual does not contain instructions for the operation of the complete turbine system. For turbine or plant operating instructions, contact the plant-equipment manufacturer.

Manual 85018 describes the 505E Digital Governor for extraction steam turbines.

Part Number Options

Part Number	Power
9907-162	HVAC (180–264 Vac)
9907-163	AC/DC (88–132 Vac or 90–150 Vdc)
9907-164	LVDC (18–32 Vdc)
Optional Bulkhead Mounting Box (NEMA 4X) P/N 8923-439	

General Installation and Operating Notes and Warnings

This equipment is suitable for use in Class I, Division 2, Groups A, B, C, and D (Class I, Zone 2, Group IIC) or non-hazardous locations.

The 505s are suitable for use in European Zone 2, Group II environments per compliance with EN60079-15, Electrical apparatus for explosive atmospheres – Type of protection ‘n’

These listings are limited only to those units bearing the certification identification.

Field wiring must be rated at least 75 °C for operating ambient temperatures expected to exceed 50 °C.

Peripheral equipment must be suitable for the location in which it is used.

Wiring must be in accordance with North American Class I, Division 2 or European Zone 2 wiring methods as applicable, and in accordance with the authority having jurisdiction.



WARNING

Explosion hazard—Do not connect or disconnect while circuit is live unless area is known to be non-hazardous.

Explosion Hazard—Substitution of components may impair suitability for Class I, Division 2.

**AVERTISSEMENT**

Risque d'explosion—Ne pas raccorder ni débrancher tant que l'installation est sous tension, sauf en cas l'ambiance est décidément non dangereuse.

Risque d'explosion—La substitution de composants peut rendre ce matériel inacceptable pour les emplacements de Classe I, Division 2.

**WARNING**

Do not use any test points on the power supply or control boards unless the area is known to be non-hazardous.

**AVERTISSEMENT**

Ne pas utiliser les bornes d'essai du block d'alimentation ou des cartes de commande à moins de se trouver dans un emplacement non dangereux.

505 Software Changes Covered in This Manual Revision

1. PROGRAM MODE: Added an error check to ensure Rated Speed (when programmed as a gen set) was less than max gov.
2. SERVICE MODE: Changed the hold changes for Min Load to come from the Breaker Logic header's Hold Changes input. Previously the hold changes command was selected under the Speed Control Settings header.
3. SPEED SETPOINT RATES: Changed the minimum adjustment range for all speed setpoint rates to 0.01 (was 0.1).
4. AUX LIMITER or CONTROLLER: Added logic to ensure the inhibited status of Aux control when the input is failed. In addition, changed Aux re-enable logic such that when a failed aux input is restored there is no glitch to the speed LSS. Also changed breaker open logic to correct a Gen Opening Aux actuator output glitch.
5. AUX CONTROLLER: Changed the speed setpoint aux biasing logic to only allow the speed control limiting action (while in aux control) to be active when the speed setpoint reaches max gov. Prior to this fix the speed limiter could come into control during an extreme transient.
6. AUX DIRECT ENTERED SETPT: Changed Aux Entered setpoint to be reset/stopped on a shutdown pulse rather than held disabled on a shutdown condition. This change allows the Aux Limiter function direct setpoint entry even when the unit is tripped.
7. AUX and CASC DROOP: Changed the droop feedback lag-tau tunable range from a max of 10 to a max of 1000.
8. MODBUS: Changed the Gen and Tie Open alarms for Aux, Casc, and Remote to match the Modbus[®] * listing—the software eventlatch inputs were reversed/backwards with the Modbus listing.
*—Modbus is a trademark of Modicon, Inc.
9. CONTROLLED STOP: Made the Controlled Stop abort if speed raise/lower is selected or another control mode is selected. This can be tuned-out by setting CNTRL_STOP.RL_STOP.IN_2=*false in the debug mode.
10. ANALOG INPUTS: Changed max setting on the delay time's tunable range from 3 ms to 3000 ms. The analog input failure delay setting is defaulted to zero but can be adjusted up to 3000 ms using the debug mode MAIN.Aix.LATCH_DLY where x is the analog input number. Added a tunable single pole filter (LAG) to each analog input. Output/input = 1/(1+st) where t = 1/(2(pi)f) = LAG_TAU. The Lag-tau is defaulted to zero but can be adjusted in the debug mode using MAIN.Aix_LAG.LAG_TAU where x is the analog input number (1-6).

General Description

General

The 505 microprocessor-based control is designed to control single or dual (split range) actuator steam turbines (extraction steam turbines require the 505E version). The 505 is field programmable which allows a single design to be used in many different control applications and reduces both cost and delivery time. It uses menu driven software to instruct site engineers on programming the control to a specific generator or mechanical drive application. The 505 can be configured to operate as a stand-alone unit or in conjunction with a plant's Distributed Control System.

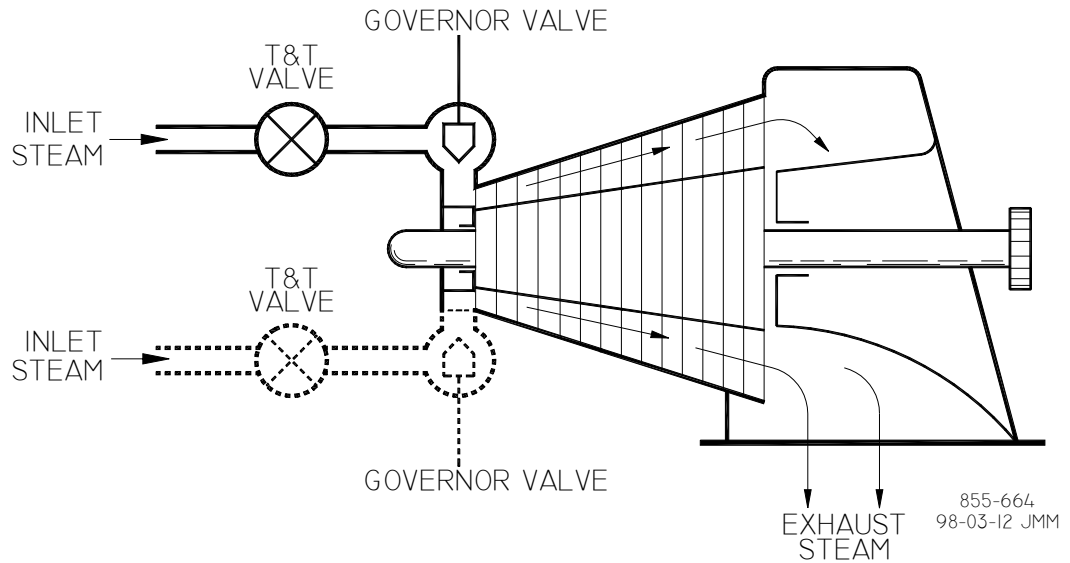

Figure 1-1. Typical Single or Dual Inlet Steam Turbine

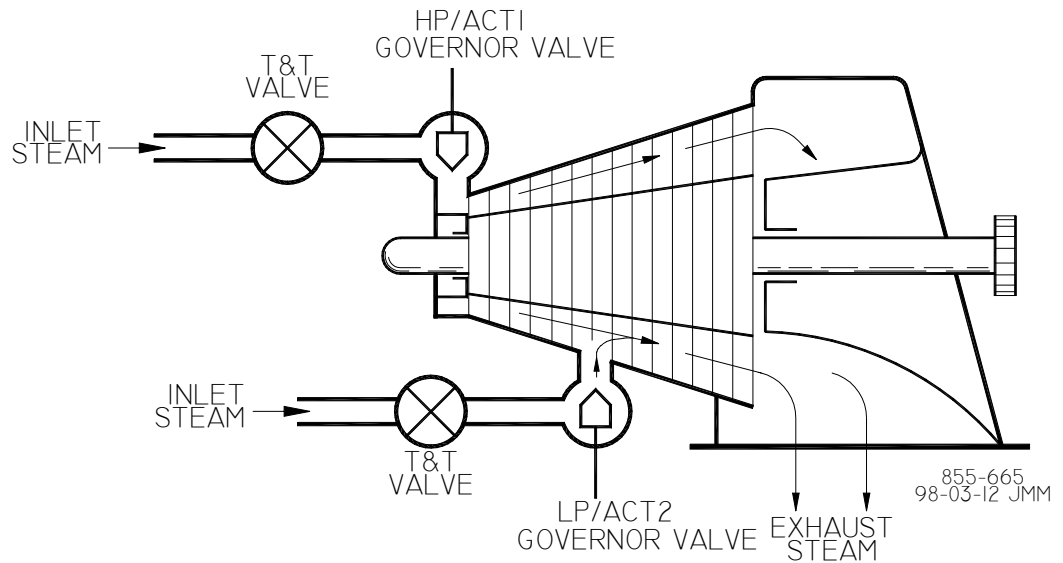

Figure 1-2. Split Range or Admission Type of Turbine Configuration

Operator Control Panel

The 505 is a field configurable steam turbine control and operator control panel (OCP) integrated into one package. A comprehensive operator control panel, including a two-line (24 characters each) display, and a set of 30 keys is located on the 505's front panel. This OCP is used to configure the 505, make On-Line program adjustments, and operate the turbine/system. Easy to follow instructions are presented in English through the OCP's two-line display and operators can view actual and setpoint values from the same screen.

Turbine Control Parameters

The 505 interfaces with one or two control valves to control one parameter at a time and limit an additional parameter, if desired. The one controlled parameter is typically speed (or load), however, the 505 could be utilized to control or limit: turbine inlet pressure or flow, exhaust (back) pressure or flow, first stage pressure, generator power output, plant import and/or export levels, compressor inlet or discharge pressure or flow, unit/plant frequency, process temperature, or any other turbine related process parameter. Refer to Volume 2 of this manual for details on applications.

Communications

The 505 can communicate directly with plant Distributed Control Systems and/or CRT based operator control panels, through two Modbus communication ports. These ports support RS-232, RS-422, or RS-485 communications using ASCII or RTU MODBUS transmission protocols. Communications between the 505 and a plant DCS can also be performed through hardwired connections. Since all 505 PID setpoints can be controlled through analog input signals, interface resolution and control is not sacrificed.

Additional Features

The 505 also provides the following features: First-Out Trip Indication (5 total trip inputs), Critical Speed Avoidance (2 speed bands), Auto Start Sequence (hot & cold starts), Dual Speed/Load Dynamics, Zero Speed Detection, Peak Speed Indication for Overspeed trip, and Isochronous Loadsharing between units (with a DSLC™ control).

Using the 505

The 505 control has two normal operating modes, the Program Mode and the Run Mode. The Program Mode is used to select the options needed to configure the control to your specific turbine application. Once the control has been configured, the Program Mode is typically never again used, unless turbine options or operation changes. Once configured, the Run Mode is used to operate the turbine from start-up through shutdown. In addition, on-line adjustments can be made using the Service Mode (see Volume 2).

505 Inputs and Outputs

Control Inputs

Two speed inputs that are jumper configurable for MPU (magnetic pickup units) inputs or proximity probes.

Six programmable analog inputs can be used as one of the following options: auxiliary input, remote auxiliary setpoint, cascade input, remote cascade setpoint, kW (load) input, remote speed setpoint, synchronizing, load sharing, both synchronizing and load sharing, and first stage pressure. The sixth analog input has isolation circuitry and should be used for a self-powered signal that is not isolated.

Sixteen contact inputs are available. Four are dedicated for shutdown, reset, raise speed setpoint, and lower speed setpoint. Another two contact inputs must be dedicated for generator breaker and utility tie breaker if the control is used in a generator application. Ten additional contact inputs can be configured. If the unit is not used in a generator application, then twelve additional contact inputs can be configured.

Four function keys on the front panel of the control. F1 and F2 are dedicated to alarm and overspeed, respectively. F3 and F4 can be used to enable or disable various functions of the control.

Control Outputs

Two actuator outputs with linearization curves; the second actuator output can be used as an extra readout if not used as an actuator output. Six 4–20 mA outputs, for meters or other readouts.

Eight Form-C relay contact outputs, six that are configurable. The two dedicated relay outputs are for shutdown and alarm indication.

Control Interfaces

Two Modbus ports, to be used as control interfaces. The protocol can be either ASCII or RTU and the communications can be RS-232, RS-422, or RS-485.

One computer (PC) port to be used for program configuration storage.

An overview of the 505 functions is shown in Figure 1-3. Use this block diagram to match the control features to the site-specific application required.

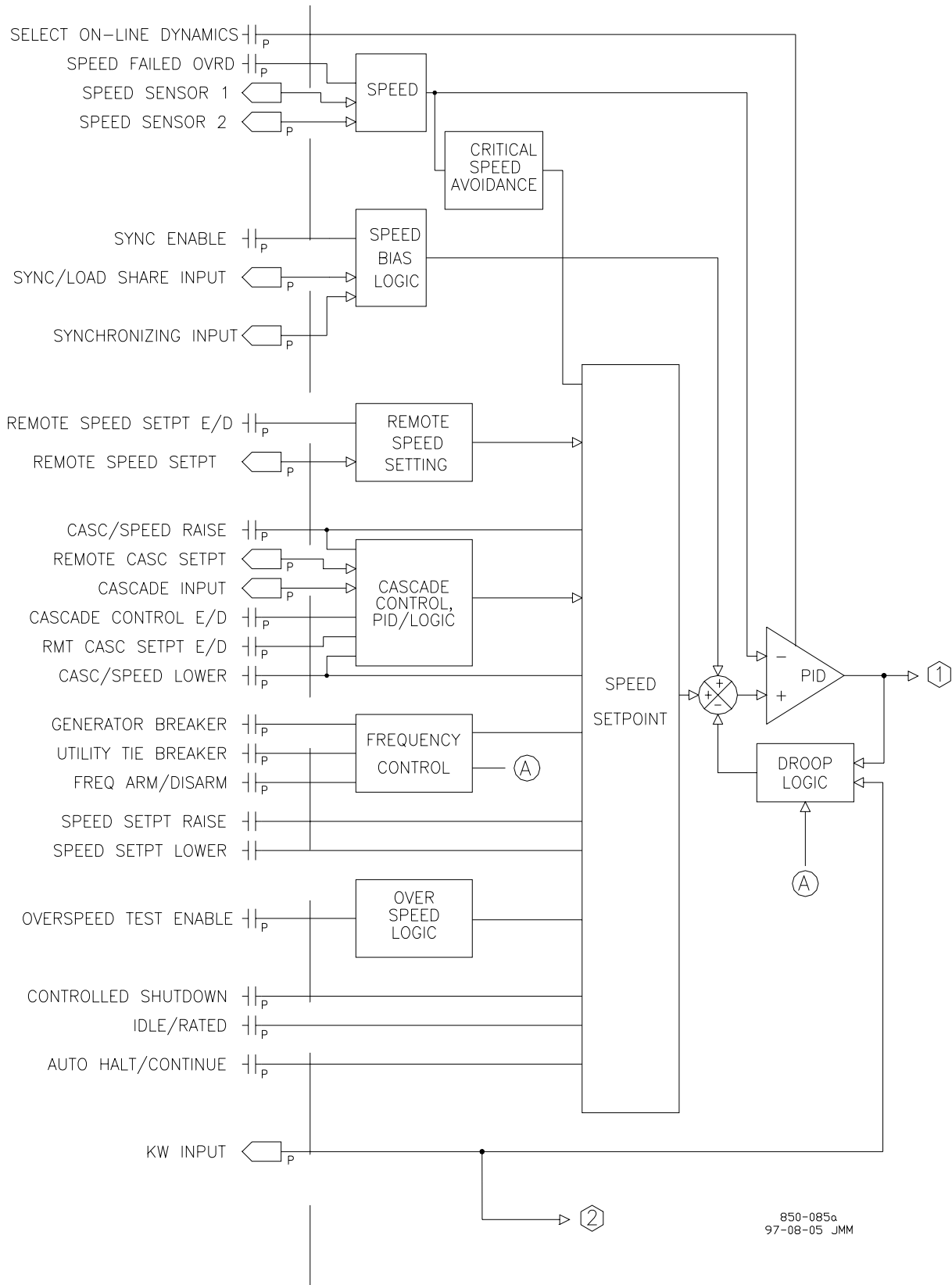
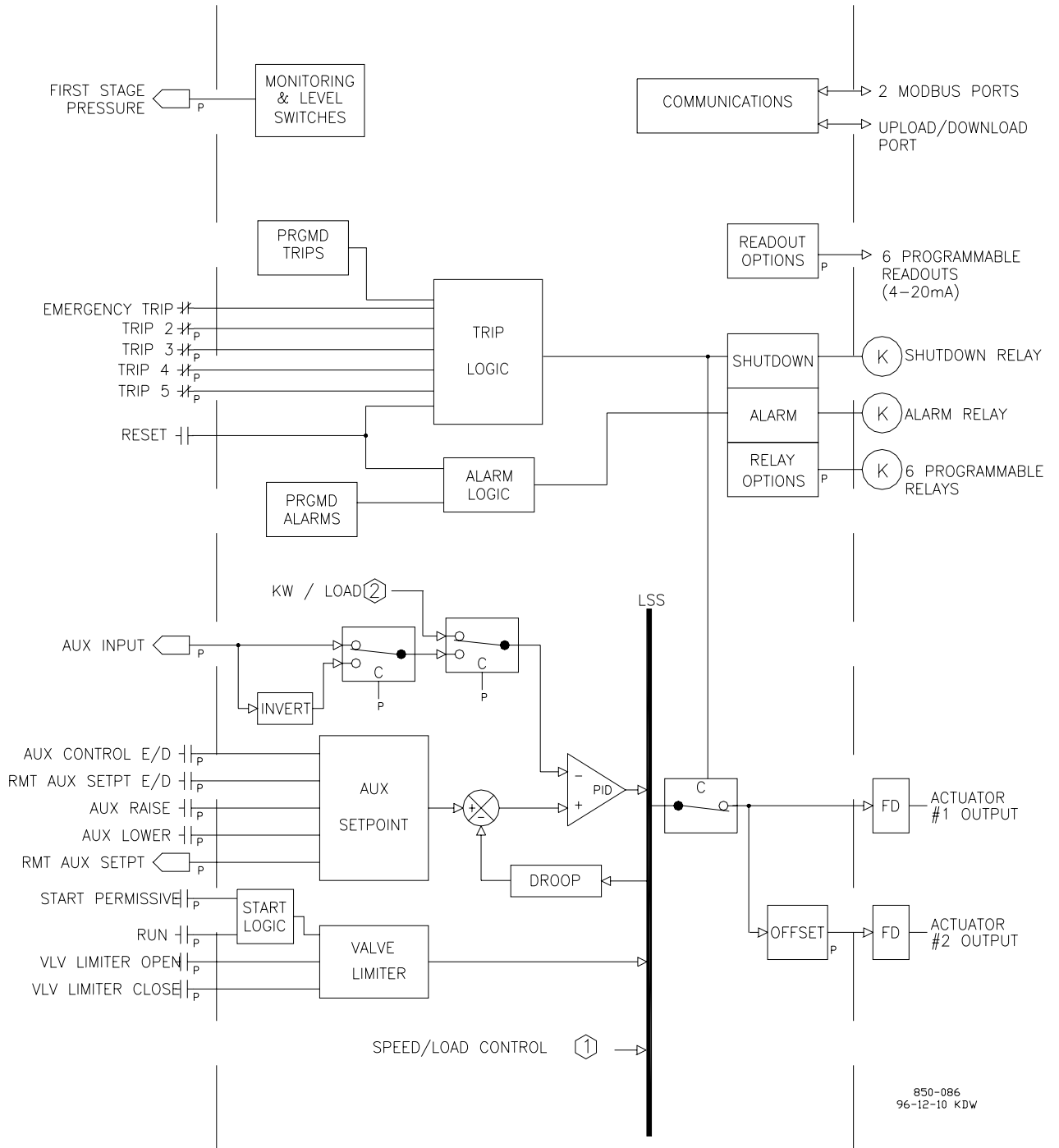

Figure 1-3a. Overview of 505 Functionality



850-086
96-12-10 KDW

Figure 1-3b. Overview of 505 Functionality

Control Overview

The 505 has two independent control channels, the speed/load and auxiliary controllers. The outputs of these two controllers are low-signal-selected (LSS) with another channel, the valve limiter. The output of the LSS directly sets the position of the actuator driver's output. In addition to these channels, the speed/load controller can be manipulated by another controller, the cascade controller. The cascade controller is 'cascaded' into the speed controller, whereby the speed controller setpoint is changed directly by the cascade controller output. The auxiliary controller can act as either a control channel or as a limiting channel. All three of these PID controllers have the option of utilizing an analog input signal to remotely position their setpoints. Additional features of the 505 include frequency control, isochronous loadsharing (with a DSLC), critical speed avoidance, idle/rated control and an automatic start sequence. There are two serial communications ports which can be used to monitor and control the turbine using Modbus protocol.

Speed Control

The speed control receives a turbine speed signal from one or two magnetic pickups or proximity probes. The speed PID (proportional, integral, derivative) control amplifier then compares this signal to the speed setpoint to generate an output signal to the actuator (through a low signal select bus).

The speed control's setpoint is adjustable with raise or lower commands through the keypad on the front of the control, remote contact inputs or the communication line. The setpoint can also be directly set by entering the new setpoint from the keypad or through either Modbus communications. In addition, an analog input can be programmed to remotely position the speed setpoint.

Remote Speed Setpoint

One of the 4–20 mA inputs can be configured to control the speed setpoint. Typically, a process control external to the 505 interfaces with this input to regulate the turbine's speed or load to control a related process.

The remote speed setpoint input directly affects the 505's speed setpoint. The maximum rate at which the remote input signal can change the speed setpoint is programmable. When the remote setpoint is enabled, the speed setpoint will move at a much slower rate until the two settings are matched at which time the speed setpoint will be allowed to move at the maximum rate. The remote speed function can be enabled and disabled as required from the front-panel keypad, remote contact inputs or the communication line.

Auxiliary Control

The Auxiliary control channel can be used to either control a parameter or limit a parameter. The Auxiliary PID controller can be used to control or limit unit load/power, plant import/export levels, inlet pressure, exhaust pressure, temperature or any other process directly related to turbine load.

The Auxiliary input is a 4–20 mA current signal. The Auxiliary PID control amplifier compares this input signal with a setpoint to produce a control output to the digital LSS (low-signal select) bus. The LSS bus sends the lowest signal to the actuator driver circuitry.

The Auxiliary setpoint is adjustable with raise or lower commands through the keypad on the front of the control, through remote contact inputs or through the communication links. Also, the setpoint can be directly set by entering the new setpoint from the keypad or through either Modbus communications. In addition, an analog input can be programmed to remotely position the Auxiliary setpoint.

Remote Aux Setpoint

One of the 4–20 mA inputs can be configured to remotely adjust the aux setpoint. The remote aux setpoint input directly affects the Auxiliary setpoint. The maximum rate at which the remote input signal can change the auxiliary setpoint is programmable. When the remote setpoint is enabled, the Auxiliary setpoint will move at a much slower rate until the two settings are matched at which time the setpoint will be allowed to move at the maximum rate. The remote aux function can be enabled and disabled as required from the front panel keypad, the remote contact inputs, or the communication links.

Load Sharing Input

The 505 is capable of using an analog input to accept a load sharing signal from Woodward's Digital Synchronizer and Load Control (DSLCL). This input in conjunction with the DSLCL allows the control to isochronously loadshare with any other system using a DSLCL. The 505's internal summing junction adds this signal with the speed/load PID's reference. In addition to loadsharing, the DSLCL input to the 505 can be used to synchronize the unit to either the plant bus or to the utility.

Cascade Control

The cascade control can be configured to control any system process, related to or affected by turbine speed or load. Typically this controller is used as a turbine inlet or exhaust pressure controller.

The cascade control is a PID controller that compares a 4–20 mA process signal with the cascade setpoint. The PID controller sets the speed controller setpoint until the process signal and the setpoint match.

The cascade setpoint is adjustable with raise or lower commands through the keypad on the front of the control, the remote contact inputs, or the communication links. Also, the setpoint can be directly set by entering the new setpoint from the keypad or through Modbus communications. In addition, a remote cascade setpoint analog input can be programmed to remotely position the cascade setpoint.

Remote Cascade Setpoint

One of the 4–20 mA inputs can be configured to remotely adjust the cascade setpoint. The remote cascade setpoint input directly affects the 505's cascade setpoint. The maximum rate at which the remote input signal can change the cascade setpoint is programmable and can be changed in the Run mode. When the remote setpoint is enabled, the cascade setpoint will move at a much slower rate until the two settings are matched at which the setpoint will be allowed to move at the maximum rate. The remote cascade function can be enabled and disabled as required from the front-panel keypad, the remote contact inputs or the communication links.

Valve Limiter

The valve limiter limits the actuator output signal or valve position to aid in starting up and shutting down a turbine. The output of the valve limiter is low-signal-selected with the output of the speed/load and auxiliary control channels. The control or limiter channel asking for the lowest valve position will control valve position. Thus, the valve limiter limits the maximum valve position. The valve limiter can be adjusted through the keypad, external contact closures, or Modbus commands.

The valve limiter can also be used to troubleshoot system dynamics problems. If it is believed that the 505 is the source of system instability, the valve limiter can be positioned to manually take control of the valve position. Care should be taken when using the valve limiter in this fashion, so as to not allow the system to reach a dangerous operating point.

Starting Features

The 505 provides options for three different starting modes: automatic, semi-automatic, and manual. One of these modes must be programmed to get the turbine from a shutdown state to speed control at minimum speed. The start mode configured and minimum governor controlling speed will depend on normal plant starting procedures and turbine manufacturer's recommendations.

If an idle speed is programmed (either idle/rated or auto start sequence modes), the 505 can provide automatic speed control and critical speed avoidance. A 'Run' command can be given through the 505 keypad, a remote contact input, or Modbus communications. In addition, an optional 'Start Permissive' contact input can be programmed to prevent a start if, for example, the trip-throttle or stop valve is not closed.

Idle/Rated

The idle/rated function gives an operator the ability to move between a programmed idle speed and a programmed rated speed at a configured rate. The selection of idle or rated speed setpoint positions can be made through the front panel keypad, through remote contact inputs, or through the Modbus communications links. The idle/rated function can also be programmed as a ramp-to-rated function only.

Auto Start Sequence

The auto start sequence function gives the operator the ability to start from a programmed low idle speed, hold there until the programmed warm-up time has expired, then go to a programmed high idle speed, hold there until the programmed high idle warm-up time has expired, and finally move to the programmed rated speed setpoint. The hold times and the acceleration rates are dependent on whether the turbine is considered 'hot' or 'cold' based on the time the turbine has been shut down. When the turbine is between hot and cold conditions, the control interpolates between the hot and cold data points to determine the appropriate startup rates and hold times.

The auto start sequence can be stopped and started, if desired, by programming and using the auto start sequence halt/continue commands. The selection of halt or continue can be made through the 505 keypad, remote contact inputs or Modbus communications. In addition, the auto start sequence can be programmed to automatically halt at each idle setpoint.

Critical Speed Avoidance

In many turbines, it is desirable to avoid certain speeds or speed ranges (or pass through them as quickly as possible) due to excessive turbine vibration or other factors. During programming, two critical speed avoidance bands may be selected. These bands may be any speed ranges that is less than the minimum governor speed setting. Either the Idle/Rated or the Auto Start Sequence functions must be programmed to perform critical speed avoidance. Within a critical speed range, the 505 moves the speed setpoint at the critical speed rate programmed and does not allow the speed setpoint to stop within the critical speed avoidance band. If the turbine is accelerating through a critical avoidance band and excessively high vibrations are experienced, selecting the speed setpoint lower command will bring the unit back to the lower limit of the band.

Block Diagrams

Overviews of possible 505 configurations are shown in Figures 1-5 through 1-7. Use these block diagrams to match the control features to the site-specific application requirements. Figure 1-4 lists symbols and their respective explanations. The Cascade and auxiliary PIDs are optional controllers, and are shown in the following diagrams for PID relationship purposes only.

SIGNAL FLOW :

— — — DISCRETE SIGNALS
 _____ ANALOG SIGNALS

SIGNAL FLOW IS FROM LEFT TO RIGHT. ALL INPUTS ENTER FROM THE LEFT. ALL OUTPUTS EXIT TO THE RIGHT. EXCEPTIONS NOTED.

CUSTOMER INPUT/OUTPUT :

INPUTS ORIGINATE ON THE LEFT SIDE OF THE DRAWING. OUTPUTS TERMINATE ON THE RIGHT SIDE OF THE DRAWING.

CONTACT INPUTS.

⋈ SYMBOLS INDICATE SWITCH CONTACT INPUTS.
 LINE THROUGH SYMBOL INDICATES NORMALLY CLOSED CONTACT.

⬡DC⬢ INDICATES INTERCONNECTING LOGIC IN FUNCTIONAL.

⬢FD⬢ INDICATES FINAL DRIVER (ACTUATOR) OUTPUT

FUNCTION SYMBOLS :

COMMON GOVERNOR FUNCTIONS ARE REPRESENTED BY RECTANGULAR BLOCKS. A DESCRIPTION OF THE FUNCTION IS SHOWN INSIDE THE BLOCK.

EXAMPLE :

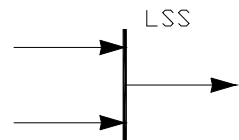

LOW SIGNAL SELECTOR WHERE LOWEST INPUT SIGNAL IS PASSED TO THE OUTPUT.

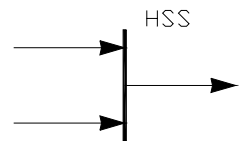

HIGH SIGNAL SELECTOR WHERE HIGHEST INPUT SIGNAL IS PASSED TO THE OUTPUT.

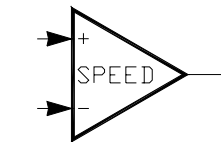

CONTROLLERS WHICH HAVE PROPORTIONAL, INTEGRAL, AND DERIVATIVE DYNAMICS ARE REPRESENTED BY TRIANGLES.

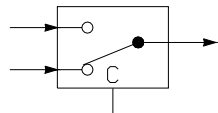

ANALOG SWITCH. THE SWITCH CHANGES STATE WHEN THE LOGIC TO THE (C) INPUT IS TRUE. ALL SWITCHES ARE SHOWN IN THE FALSE STATE.

855-667
 02-12-31

Figure 1-4. Overview of 505 Functionality Notes

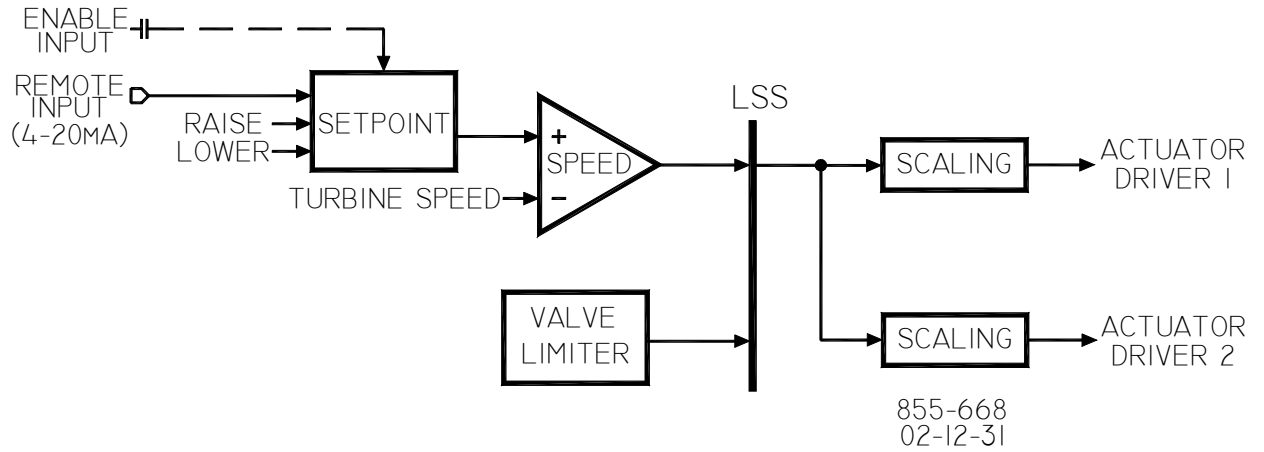

Figure 1-5. Single or Split-Range Turbine Configurations (Speed PID with Remote Setpoint)

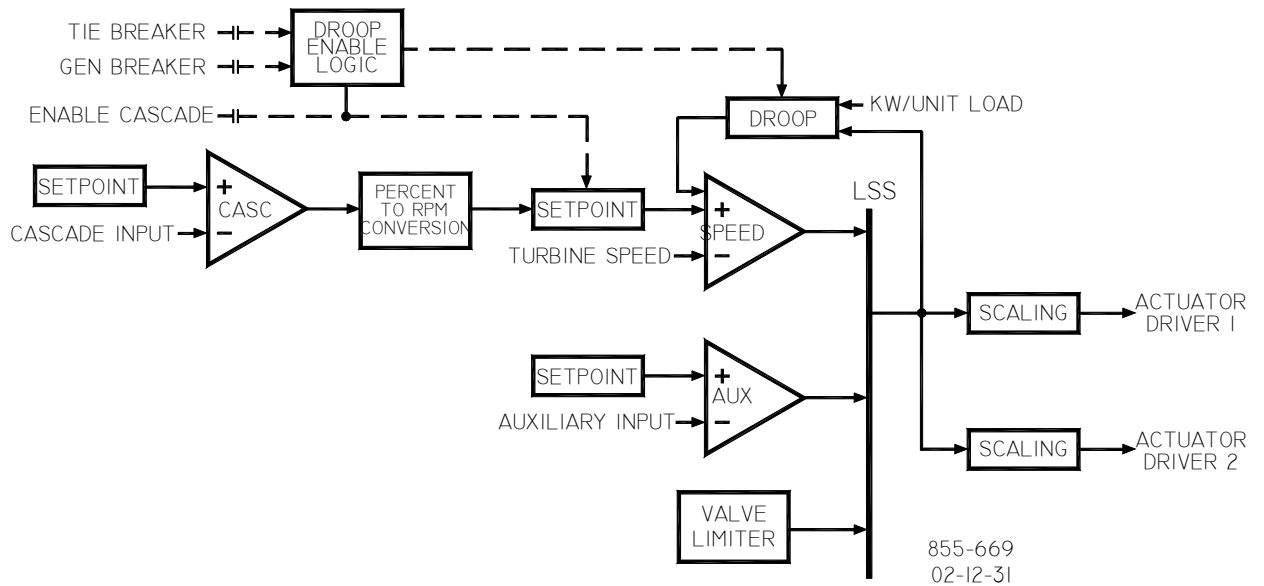

Figure 1-6. Single or Split-Range Turbine Configurations (Auxiliary PID Configured as a Limiter)

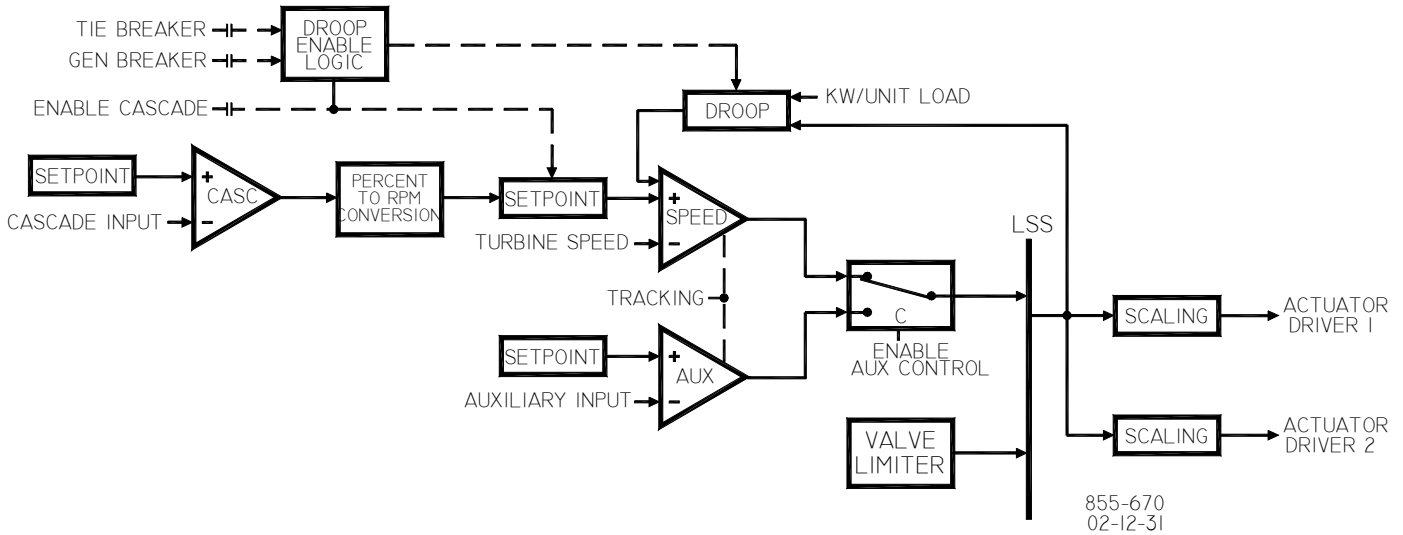
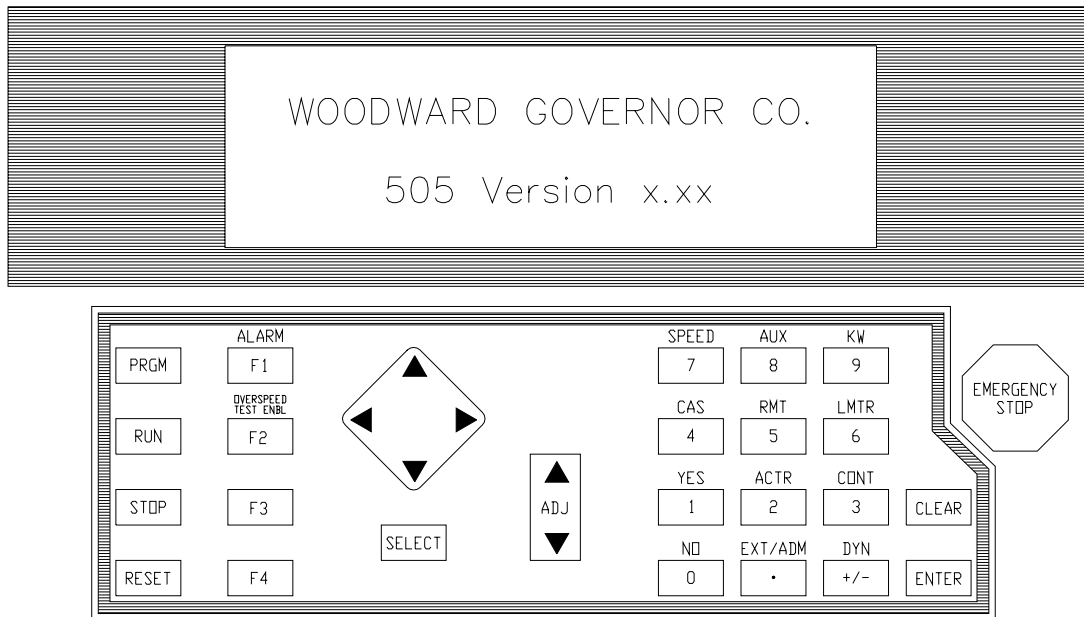

Figure 1-7. Single or Split-Range Turbine Configurations (Auxiliary PID Configured as a Controller)

Keypad and Display

The 505's service panel consists of a keypad and LED display located on the front of the control. The LED display has two, 24 character lines that can be used to display operating parameters and troubleshooting parameters in plain English. Also, there are 30 keys available to provide complete control from the front of the 505. No additional control panels are required to operate the turbine, every turbine control function can be performed from the 505's front panel.



850-084
96-02-06 KDW

Figure 1-8. 505 Key Pad and Display

A description of each key's function follows. Some descriptions refer to the function blocks contained in the programming (Chapter 4) and operating flowcharts (Chapter 5).

SCROLL :

The large diamond shaped button in the middle of the keypad with arrows at each of its four corners. The < > (scroll left, right) moves the display left or right through the function blocks of the Program or Run Mode. The \uparrow , \downarrow (scroll up, down) moves the display up or down within a function block of the Program or Run Mode.

SELECT:

The Select key is used to select control of the 505 display's top or bottom line variable. The @ sign is used to indicate which line (variable) can be adjusted by the adjust keys. Only when there is a changeable variable on both lines (dynamics, valve calibration modes) does the "select key" and @ sign determine which line variable can be adjusted. When there is only one variable per screen the "select key" and @ sign's position are irrelevant.

ADJ (adjust):

In the Run Mode, " " moves any adjustable parameter up (larger) and " " moves any adjustable parameter down (smaller).

PRGM (program):

When the control is shutdown this key selects the Program Mode. While in the Run Mode this key selects a Program Monitor Mode. In the Program Monitor Mode the program can be viewed but not changed.

RUN:

Initiates a turbine run or start command from the (CONTROLLING PARAMETER/PUSH RUN or PRGM) state.

STOP:

Initiates a controlled turbine shutdown (Run Mode) once verification is given. The "Stop" command can be disabled through a Service Mode setting (under 'Key Options').

RESET:

Resets/clears Run Mode alarms and shutdowns. Pressing the key also returns the control to the (CONTROLLING PARAMETER/PUSH RUN OR PRGM) status after a shutdown.

0/NO:

Enters 0/NO or disable.

1/YES:

Enters 1/YES or enable.

2/ACTR (actuator):

Enters 2 or displays the actuator position (Run Mode).

3/CONT (control):

Enters 3 or displays the parameter which is in control (Run Mode); press the Scroll down arrow to display the control's last trip cause, highest speed reached, and local/remote status (if used).

4/CAS (cascade):

Enters 4 or displays the cascade control information (Run Mode).

5/RMT (remote):

Enters 5 or displays the remote speed setpoint control information (Run Mode).

6/LMTR (valve limiter):

Enters 6 or displays the valve limiter information (Run Mode)

7/SPEED:

Enters 7 or displays the speed control information (Run Mode).

8/AUX (auxiliary):

Enters 8 or displays the auxiliary control information (Run Mode).

9/KW (load):

Enters 9 or displays the kW/load or first stage pressure information (Run Mode).

CLEAR:

Clears Program Mode and Run Mode entries and takes control out of its present mode.

ENTER:

Enters new values in the Program Mode, and allows the "direct entry" of specific setpoint values in the Run Mode.

DYNAMICS (+/-):

Accesses the dynamic settings of the parameter controlling the actuator position in the Run Mode. The dynamics adjustments can be disabled through a Service Mode setting (under 'Key Options'). This key will also change the sign of a value being entered.

· (DECIMAL KEY)

Enters decimal point in number being entered from front panel.

ALARM (F1):

Displays the reason for any alarm condition (last/newest alarm) when the key's LED indicator is illuminated. Press the Scroll down arrow (diamond key) to display additional alarms.

OVERSPEED TEST ENABLE (F2) :

Permits the speed reference to be raised beyond the maximum controlling speed set point to test either the electrical or mechanical overspeed trip.

F3 (function key):

Programmable function key for enabling or disabling programmable control functions.

F4 (function key):

Programmable function key for enabling or disabling programmable control functions.

EMERGENCY SHUTDOWN BUTTON:

Large red octagonal button on the front of the enclosure. This is an Emergency Shutdown command for the control.

Watchdog Timer/CPU Fault Control

A watchdog timer and CPU fault circuit monitors the operation of the microprocessor and microprocessor memory. If the microprocessor fails to reset the timer within 15 milliseconds of the last reset, the CPU fault-control will activate the reset output. This resets the CPU, de-energizes all relay outputs and turns off all milliamp outputs.

Chapter 2. Installation Procedures

Introduction

This chapter provides instructions on how to mount and connect the 505 into a system. Hardware dimensions, ratings, and jumper configurations are given to allow a customer to mount, wire, and configure the 505 package to a specific application.

Electrical ratings, wiring requirements, and options, are provided to allow a customer to fully install the 505 into a new or existing application.

Mechanical Data and Hardware Installation

If so labeled on the enclosure, the 505 is UL/CUL listed for use in hazardous locations in UL file E156028. This Equipment is suitable for use in Class I, Division 2, Groups A, B, C, and D (Class I, Zone 2, Group IIC) or non-hazardous locations only.

The 505s are suitable for use in European Zone 2, Group II environments per compliance with EN60079-15, Electrical apparatus for explosive atmospheres – Type of protection ‘n’

These listings are limited only to those units bearing the certification identification.

Field wiring must be rated at least 75 °C for operating ambient temperatures expected to exceed 50 °C.

Wiring must be in accordance with North American Class I, Division 2 or European Zone 2 wiring methods as applicable, and in accordance with the authority having jurisdiction.

Peripheral equipment must be suitable for the location in which it is used.



WARNING

Explosion hazard—Do not connect or disconnect while circuit is live unless area is known to be non-hazardous.

Explosion Hazard—Substitution of components may impair suitability for Class I, Division 2.



AVERTISSEMENT

Risque d'explosion—Ne pas raccorder ni débrancher tant que l'installation est sous tension, sauf en cas l'ambiance est décidément non dangereuse.

Risque d'explosion—La substitution de composants peut rendre ce matériel inacceptable pour les emplacements de Classe I, Division 2.



WARNING

Do not use any test points on the power supply or control boards unless the area is known to be non-hazardous.

**AVERTISSEMENT**

Ne pas utiliser les bornes d'essai du block d'alimentation ou des cartes de commande à moins de se trouver dans un emplacement non dangereux.

Enclosures

Figure 2-1 shows 505 control layout and mounting pattern. The 505 digital control is housed in a flush mount enclosure. This enclosure is designed for installation within a control room panel or cabinet, and by itself, cannot be bulkhead-mounted. The 505 package, once properly installed within a NEMA4X panel or cabinet meets NEMA 4X ratings. A gasket is attached to the rear side of the package's bezel to properly seal the 505's face-plate to a panel. All field wiring connects to the 505 through removable terminal blocks located on the 505's back side.

The 505's internal components are industrial grade. These components include the CPU (central processing unit), its memory, the switching power supply, all relays, all Input/Output circuitry, and all circuitry for the front panel display, touch keypad, and the serial communications.

An optional NEMA-4X enclosure is available to allow the 505 to be bulkhead mounted (Figure 2-2). The 505 digital control mounts on the front door of the enclosure. This allows for easy service access through the enclosure's front door. This bulkhead mounted enclosure has two removable gland plates attached to the bottom. A user may cut appropriately sized conduit openings (up to 1.5") as required, in the removable gland plates for wiring access. For EMI reasons, it is recommend that all low-current wire (terminals 52 through 121) be separated from all high-current wire (terminals 1 through 51).

Mounting

The standard 505 package must be mounted to allow sufficient room for wiring access. Eight front panel screws permit secure mounting. The standard 505 weighs approximately 4 kg (9 lb), and has an operating range of -25 to $+65$ °C ambient air temperature.

The optional enclosure permits the control to be bulkhead mounted. See Figure 2-2 for mounting dimensions. This enclosure weighs approximately 10 kg (22 lb), and allows an operating range of -20 to $+60$ °C ambient air temperature.

505 Hardware Jumpers

To allow the 505 the flexibility of interfacing with different types of speed probes, transducers, and communication cables, user changeable jumpers are used. These jumpers are accessed by taking the 505's back cover off and are located on the I/O module. Refer to Table 2-1 for jumper options and Figure 2-4 for jumper locations. Each set of jumpers is used to select between two or three interface options for one circuit (see Figure 2-3). Of the three position jumper options provided only one interface option at a time can be selected. Power should be removed before the jumpers are accessed, and proper ESD precautions should be taken before any contact is made with any part of the circuit board.

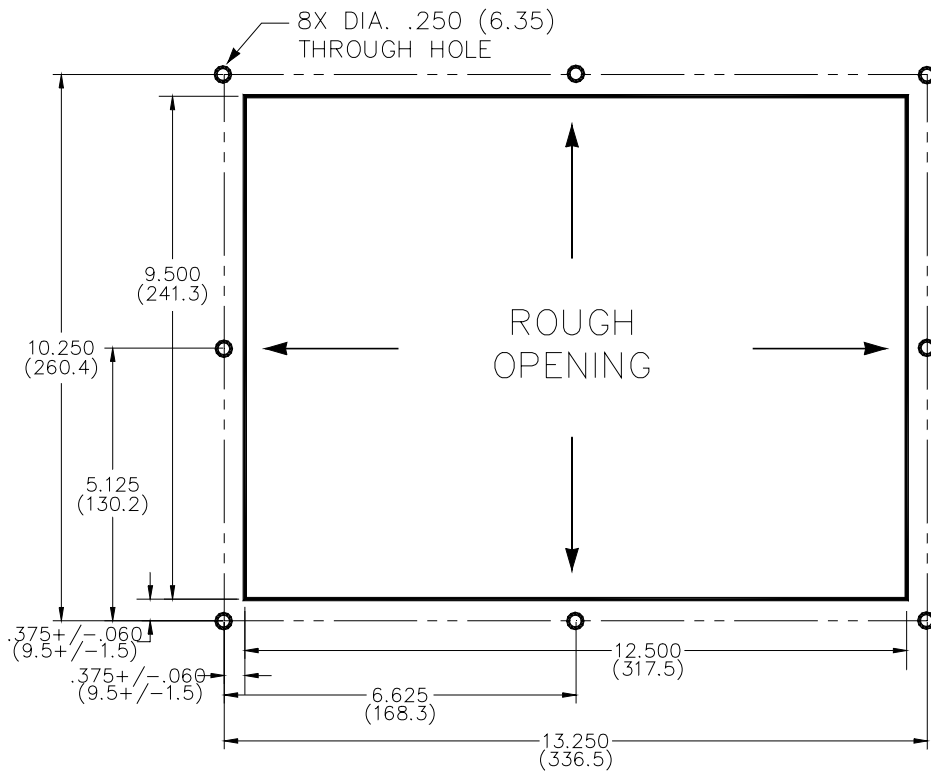
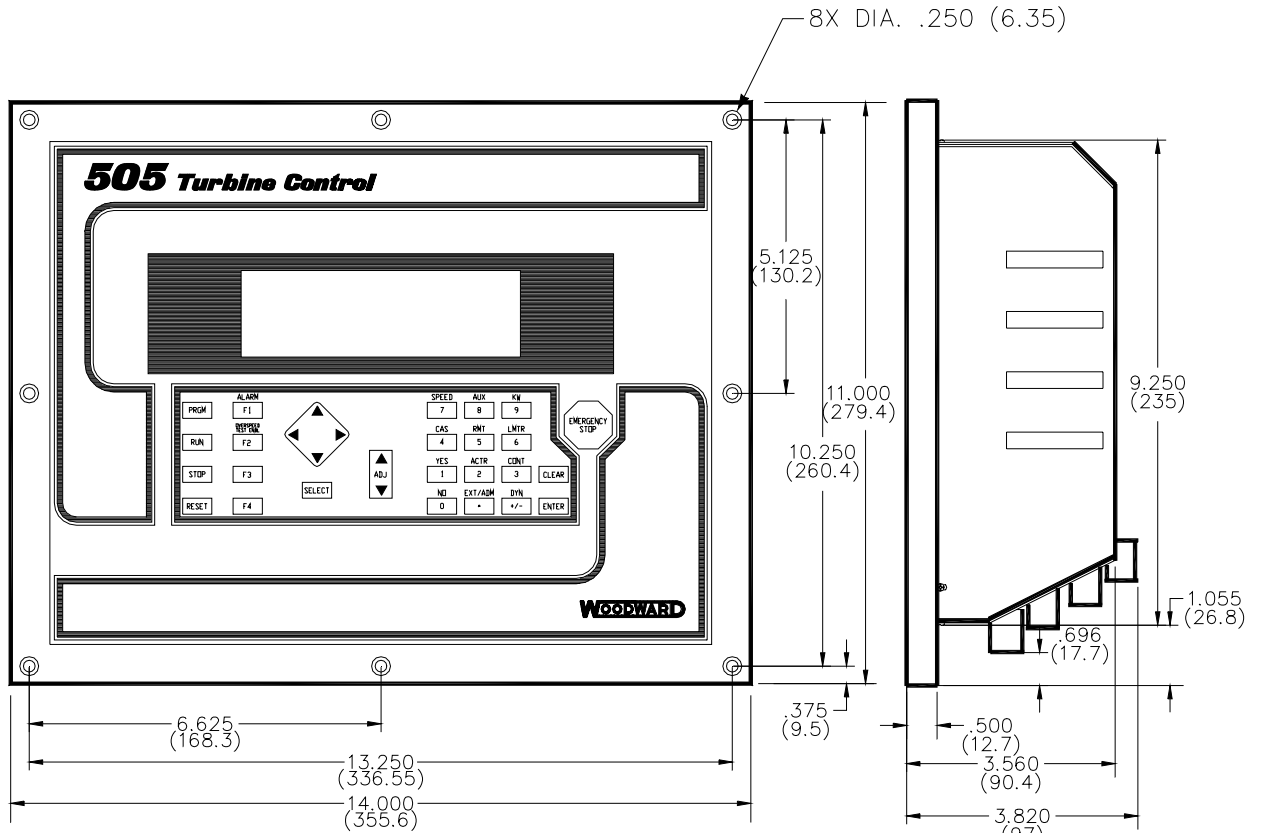

MOUNTING PATTERN

850-073
96-04-15 KDW

Figure 2-1. 505 Control Layout (Standard Enclosure)

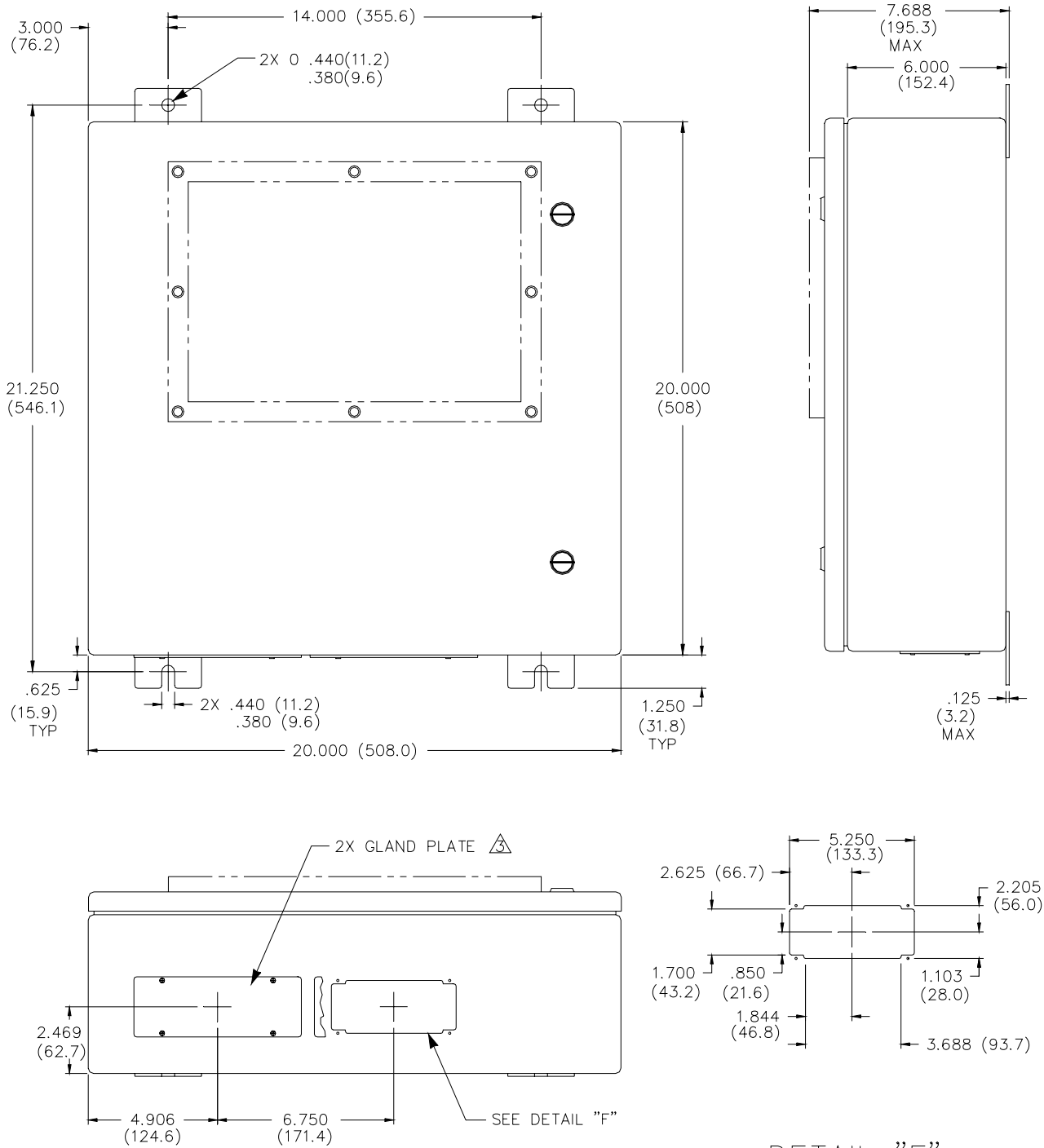

CUSTOMER OUTLINE AND INSTALLATION NOTES:

- ⚠ DIMENSIONS ARE IN INCHES WITH MILLIMETERS (MM) SHOWN IN PARENTHESIS.
- ⚠ #8-32 STUD IN ENCLOSURE BODY WALL IS PROVIDED FOR CUSTOMER GROUND WIRE.
- ⚠ GLAND PLATES ARE PROVIDED FOR INSTALLATION OF CONDUIT HUBS FOR WIRE ENTRY INTO THE ENCLOSURE.

DETAIL "F"
GLAND CUTOUT IN
ENCLOSURE BODY
TYP 2 PLACES

850-143
96-04-15 KDW

Figure 2-2. 505 Bulkhead-Mounted Enclosure

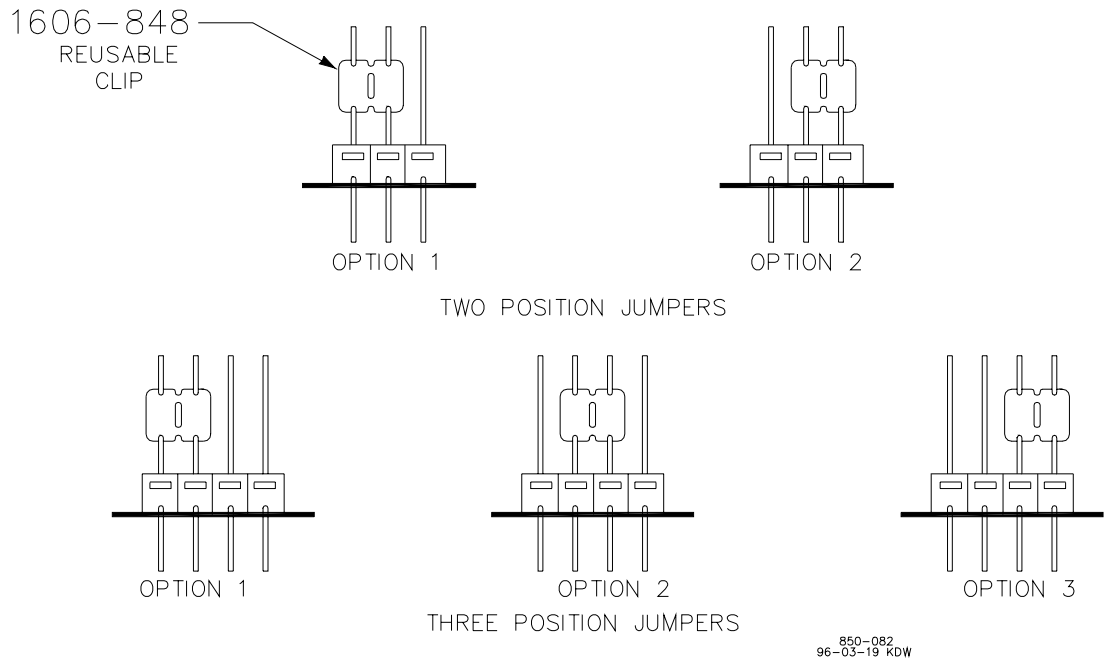

Figure 2-3. Jumper Options

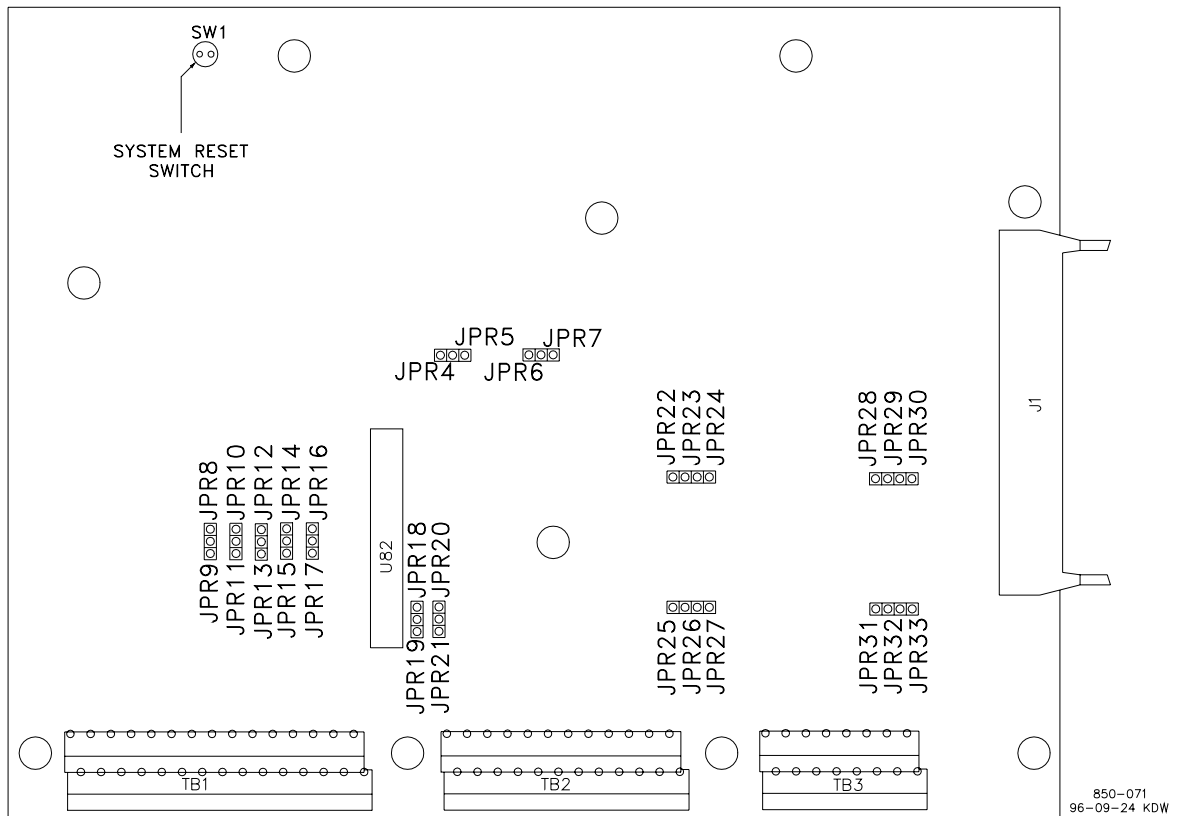

Figure 2-4. Jumper Locations

Function	Jumpers
SPEED SENSOR #1 MPU	JPR7, JPR21 *
SPEED SENSOR #1 PROX. PROBE	JPR6, JPR20
SPEED SENSOR #2 MPU	JPR5, JPR19 *
SPEED SENSOR #2 PROX. PROBE	JPR4, JPR18
ANALOG INPUT #1-LOOP POWERED-(2—WIRE)	JPR10
ANALOG INPUT #1-SELF-POWERED	JPR11 *
ANALOG INPUT #2-LOOP POWERED-(2—WIRE)	JPR8
ANALOG INPUT #2-SELF-POWERED	JPR9 *
ANALOG INPUT #3-LOOP POWERED-(2—WIRE)	JPR14
ANALOG INPUT #3-SELF-POWERED	JPR15 *
ANALOG INPUT #4-LOOP POWERED-(2—WIRE)	JPR12
ANALOG INPUT #4-SELF-POWERED	JPR13 *
ANALOG INPUT #5-LOOP POWERED-(2—WIRE)	JPR16
ANALOG INPUT #5-SELF-POWERED	JPR17 *
COMM PORT #1 NO TERMINATIONS	JPR23, JPR26 *
COMM PORT #1 RS485/RS422 RECEIVE TERMINATION	JPR22, JPR25
COMM PORT #1 RS422 TRANSMIT TERMINATION	JPR24, JPR27
COMM PORT #2 NO TERMINATIONS	JPR29, JPR32 *
COMM PORT #2 RS485/RS422 RECEIVE TERMINATION	JPR28, JPR31
COMM PORT #2 RS422 TRANSMIT TERMINATION	JPR30, JPR33

* = DEFAULT

Table 2-1. Jumper Options Chart

Electrical Connections

Refer to Figure 2-7 for a representative 505 I/O interface schematic, and Volume 2 of this manual, for hardware Input/Output specifications.

All inputs and outputs to the 505 are made through “CageClamp” terminal blocks on the bottom of the 505 package. For EMI reasons, it is recommend that all low-current wire (terminals 52 through 121) be separated from all high-current wire (terminals 1 through 51).

The terminal blocks are screwless CageClamp style blocks. The spring clamp can be actuated by using a standard 3 mm or 1/8in flat bladed screwdriver or a snap-on thumb lever (Figure 2-5). Two snap-on thumb levers are provided with the 505 unit. The 505 terminal blocks accept wires from 0.08–2.5 mm² (27–12 AWG) wire. Two 0.8 mm² (18 AWG) or three 0.5 mm² (20 AWG) wires can be easily installed in each terminal.

The 505 control’s terminal blocks are designed to be removed by hand. After 505 input power is disconnected, the terminal blocks can be removed one at a time by prying them off using ones finger tips. When removing a terminal block, never pull on the wires connected to the terminal block.

Wires for the fixed mounted power terminals should be stripped 5–6 mm (0.22”) long. Wire for the pluggable I/O terminals should be stripped 8–9 mm (0.33”) long.

When a bulkhead enclosure is required, all electrical connections must be made through the gland plates provided on the bottom of the bulkhead mount enclosure to the terminal blocks inside. See Figure 2-2.

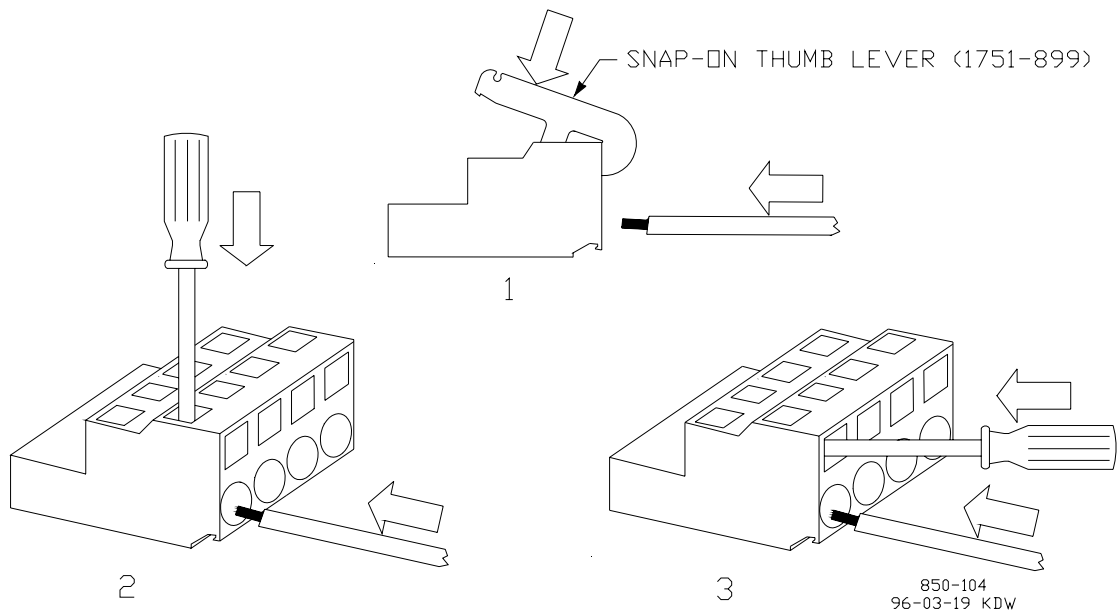

Figure 2-5. CageClamp Terminal Blocks

Power Supplies

The 505 is available with three different input power source selections. The part number of the 505 depends on the rating of the input power source it can accept. The ratings of the required input power source on each unit can be identified by the back panel sticker or control part number. The sticker will show the correct source power ratings for each unit by a punched hole next to the rating. Refer to Volume 2 for all power supply specifications.

The 505's input power supply terminal blocks accept wires from 0.08–2.5 mm² (27–12 AWG) wire. Internal fuses, in series with each input power trace, are used to protect the 505's input circuitry. All fuses are rated as slow-blow type fuses. These fuses are accessed by taking the 505's back cover off and are located on its power supply module (bottom module). Refer to Figure 2-8 for fuse locations. The ratings for the different sources of input power accepted by the 505 and the 505's internal fuse sizes are listed as follows:

18–32 Vdc	(6.25 A internal fuse, 77 VA maximum draw)
88–132 Vac @ 47–63 Hz	
or 90–150 Vdc	(2.5 A internal fuse, 143 VA maximum draw)
180–264 Vac @ 47–63 Hz	(1.5 A internal fuse, 180 VA maximum draw)

Each 505 requires a power source capable of a certain output voltage and current. In most cases this power rating is stated in Volt-Amps (VA). The maximum VA of a source can be calculated by taking the rated output voltage times the maximum output current at that voltage. This value should be greater than or equal to the 505 VA requirement.

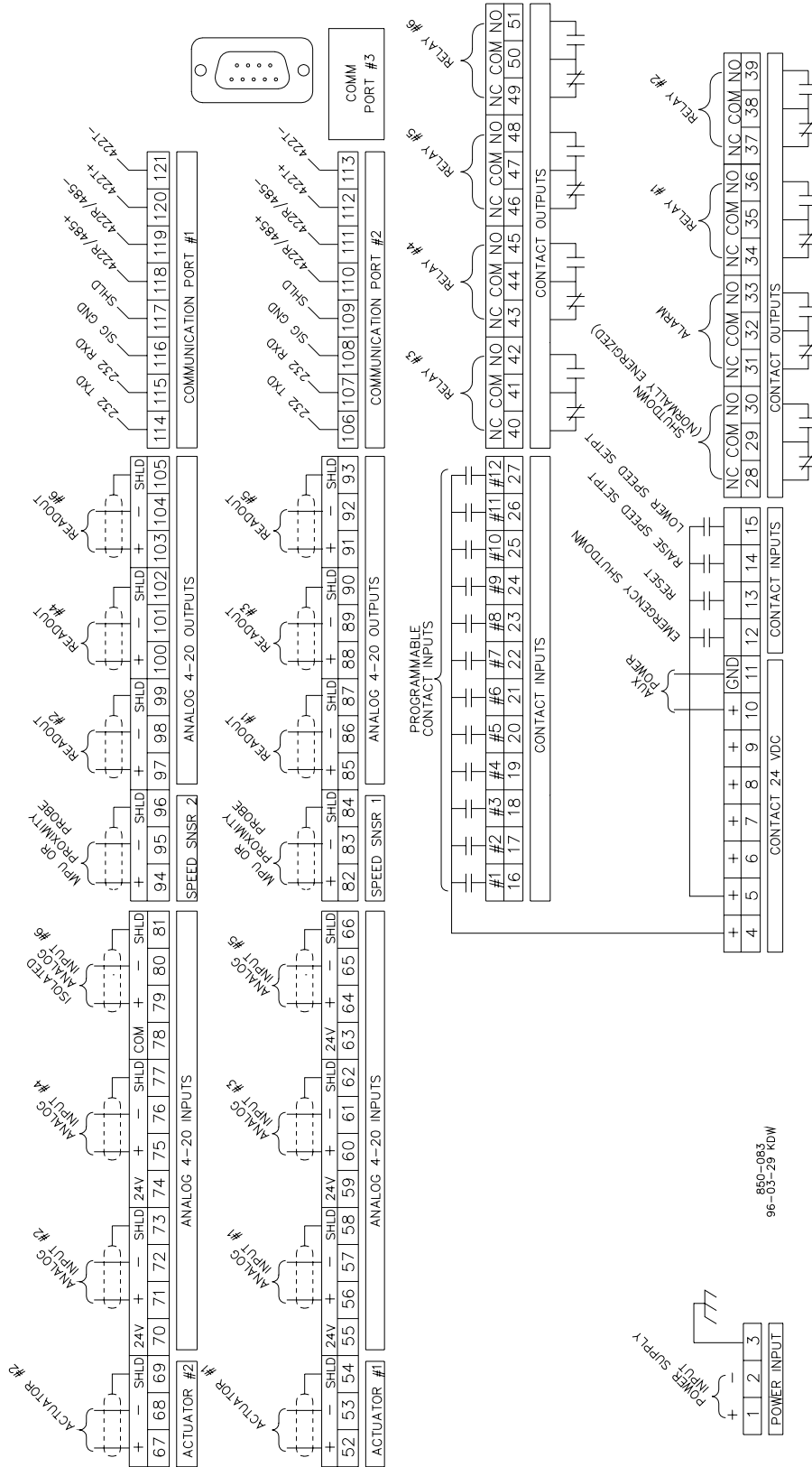

Figure 2-6. Control Wiring Diagram

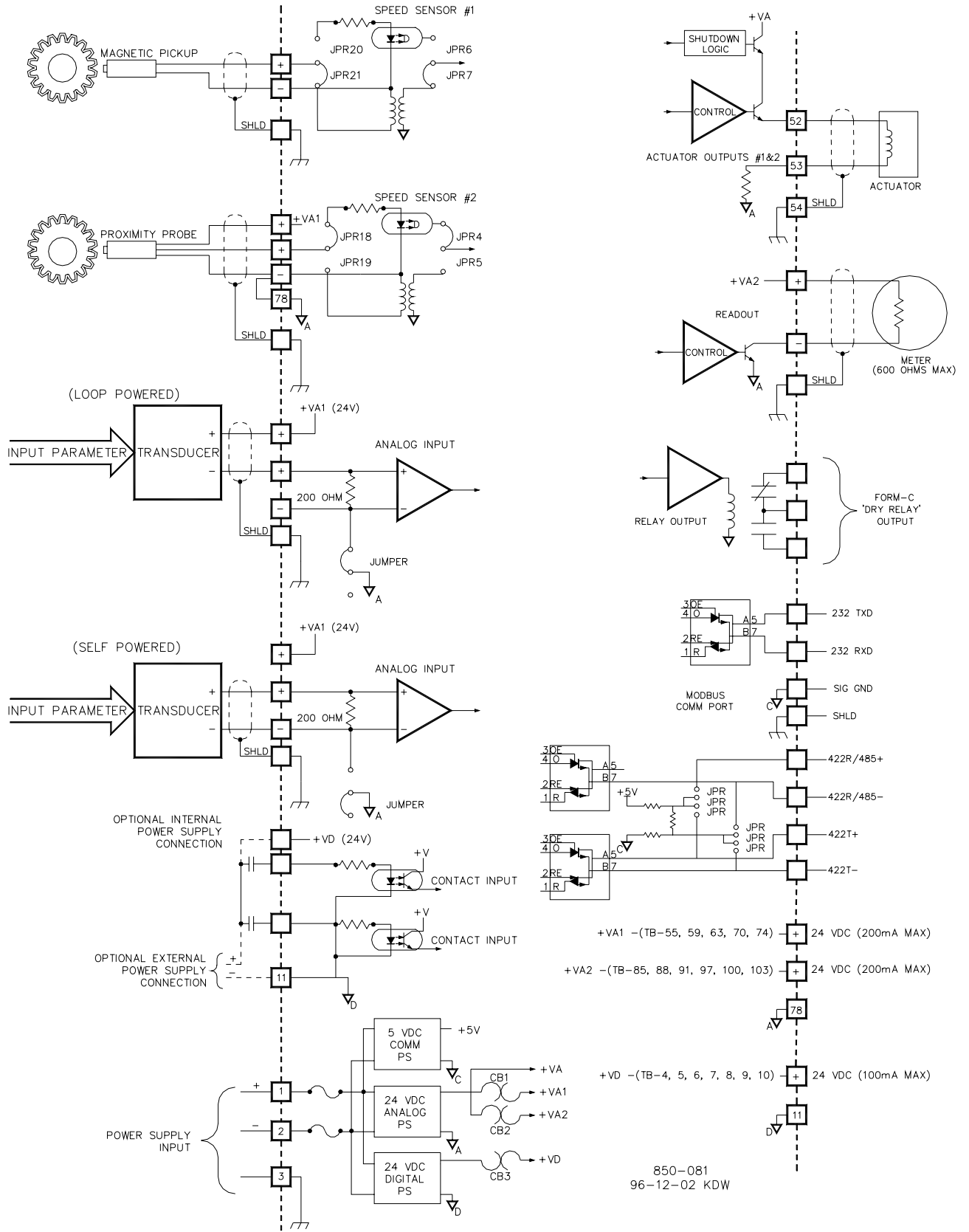

Figure 2-7. Representative 505 I/O Schematic

505 power supply holdup times are determined by the 505 power supply and input power used. The below times are based on worse case conditions (88 Vac with a possible range of 88–132 Vac when power is lost). These holdup times should be used when the 505 is powered by an Uninterruptible Power Source (UPS) to evaluate if the UPS’s switch over time is quick enough avoid a system trip. A UPS’s switch-over time must be less than the below specified holdup times:

Power Supply Holdup Times

18–32 Vdc Power Supply	14 milliseconds
88–132 Vac @ 47–63 Hz	
or 90–150 Vdc Power Supply	30 milliseconds
180–264 Vac @ 47–63 Hz Power Supply	58 milliseconds

A 24 V power supply is available, within the 505, to power external transducers or devices. This supply has two breaker protected output channels. One power supply channel (VA1) is capable of providing 24 Vdc ±10%, @ 200 mA maximum output current, to power 505 current inputs and auxiliary devices. Power connections can be made through terminals 55, 59, 63, 70, and 74 with terminal 78 as the common. Refer to Figure 2-7.



WARNING

The total current draw through terminals 55, 59, 63, 70, and 74 cannot exceed 200 mA or the 505’s internal power supply breaker (CB1) will open resulting in a possible CPU reset and trip condition. All load must be removed from the specified terminals to allow the breaker to reset.

The second power supply channel is capable of providing 24 Vdc ±10%, @ 200 mA maximum output current, to power 505 current outputs and auxiliary devices. Power connections can be made through terminals 85, 88, 91, 97, 100, and 103 with terminal 78 as the common. Refer to Figure 2-7.



WARNING

The total current draw through terminals 85, 88, 91, 97, 100 and 103 cannot exceed 200 mA or the 505’s internal power output breaker (CB2) will open resulting in a possible CPU reset and trip condition. All load must be removed from the specified terminals to allow the breaker to reset.

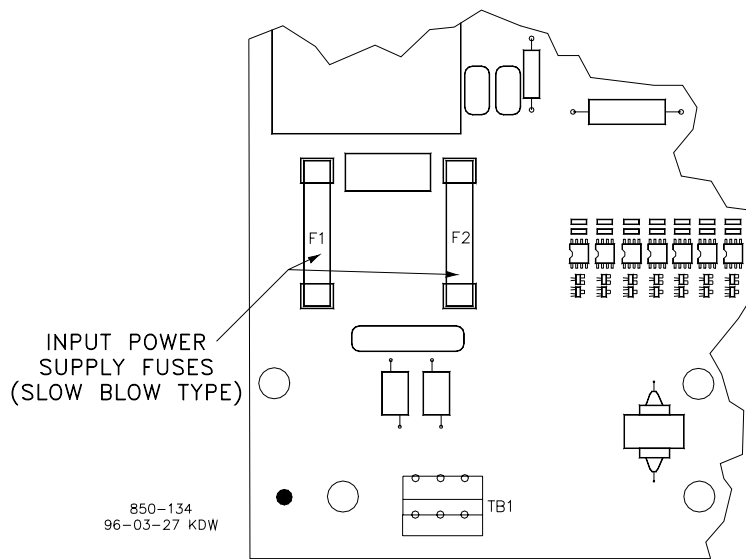

Figure 2-8. Fuse location

Shields and Grounding

An individual shield termination is provided at the terminal block for each of the speed sensor inputs, actuator outputs, analog inputs, analog outputs, and communications ports. All of these inputs should be wired using shielded, twisted-pair wiring. The shields should be connected to earth ground at all intermediate terminal blocks, as well as terminated at the control terminal block. The exposed wire length, beyond the shield, should be limited to one inch. Relay outputs, contact inputs, and power supply wiring do not normally require shielding, but can be shielded if desired.

For EMI reasons, it is recommended that all low-current wire (terminals 52 through 121) be separated from all high-current wire (terminals 1 through 51). Input Power ground terminal #3 should also be wired to external ground. Refer to Figure 2-7.

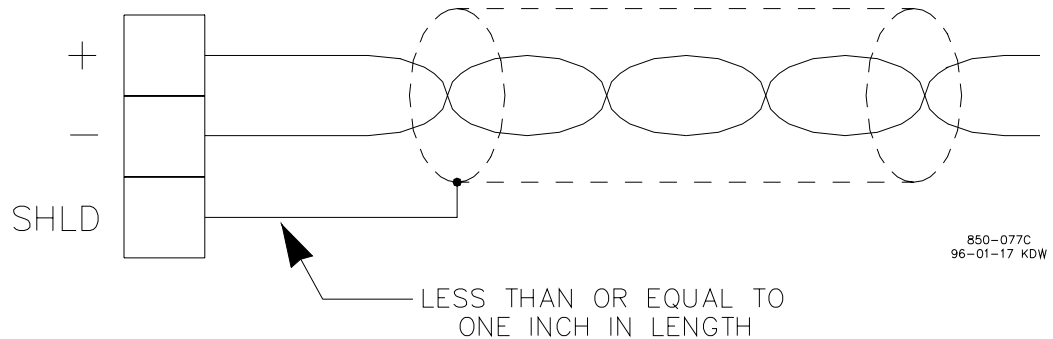

Figure 2-9. Shielded Wire Connections

Speed Sensor Inputs

To sense speed, the control accepts signals from one or two passive magnetic pickup units (MPUs) or active proximity probes mounted off of a gear which is connected or coupled to the turbine's rotor.

Because of the differences between passive MPUs, active proximity probes, and the sensing circuits required for each type, jumpers are provided to allow field configuration of each speed input depending on the type of probe used. See Table 2-1 for jumper options, and Figure 2-4 for jumper locations. Verification of jumper location is recommended before system startup or operation.

A passive MPU provides a frequency output signal corresponding to turbine speed by sensing the movement of a gear's teeth past the MPU's pole piece. The closer the MPU's pole piece is to a gear's teeth and the faster the gear turns the higher a passive MPU's output amplitude will be. The 505 must sense an MPU voltage of 1 to 25 Vrms for proper operation.

With proper MPU, gear size, and MPU-to-gear clearance, speed measurement should be capable down to 100 Hz. Standard MPU clearance is recommended to be 0.25 to 1.02 mm (0.010 to 0.040") from tooth face to pole piece. For information on selecting the correct MPU or gear size please refer to Woodward manual 82510. See Figure 2-7 for wiring schematic.

A proximity probe may be used to sense very low speeds. With a proximity probe, speed can be sensed down to 0.5 Hz. The input voltage must be between 16 and 28 Vdc for proper operation. The speed sensor input channels are isolated, so either channel can be jumper configured for a MPU or proximity probe. By being able to sense turbine speed down to this level, the 505 can be programmed to turn on or off a turbine turning gear, via a relay output. See Figure 2-7 for proximity probe wiring schematic.

It is not recommended that gears mounted on an auxiliary shaft coupled to the turbine rotor be used to sense turbine speed. Auxiliary shafts tend to turn slower than the turbine rotor (reducing speed sensing resolution) and have coupling gear back-lash, resulting in less than optimum speed control. For safety purposes it is also not recommend that the speed sensing device sense speed from a gear coupled to a generator or mechanical drive side of a system's rotor coupling.

An application may use two of the same type of speed probes, or two different types of speed probes (one MPU and one proximity probe). Both speed sensing inputs use the same programmed gear ratio and number of teeth to calculate speed, thus the speed probes used should sense speed from the same gear.

The 505 can be programmed to sense only one speed input signal. However, it is recommended that the 505 be programmed to sense two speed inputs, and that two speed probes be used with all applications to increase system reliability.

**NOTE**

The speed signal that the 505 can accept must be within the following limits:

$(T \times M \times R)/60$ must be < 15000 Hz

T = Gear Teeth

M = Overspeed Test Limit Setting

R = Gear Ratio

If the signal is not within these limits, the 505 will respond with a speed sensor frequency error during the program checking procedure.

Contact Inputs

In general, contacts must change state for a minimum of 15 milliseconds for the control to sense and register a change in state. All contact inputs accept dry contacts. Contact wetting voltage is available through terminals 4, 5, 6, 7, 8, 9, and 10. If desired, an external 18–26 Vdc power source can be used for the circuit wetting voltage. In this case terminal 11 (contact input common) must be connected to the external power source's common to establish a common reference point. Each contact input pulls 2.5 mA when closed and requires at least 1 mA and 14 V to recognize a closure command. See Figures 2-6 and 2-7 for wiring information, and Volume 2 for input specifications.

**WARNING**

The total current draw through terminals 4, 5, 6, 7, 8, 9, and 10 cannot exceed 100 mA or the 505's internal power output breaker (CB5) will open resulting in a possible CPU reset and trip condition. all load must be removed from the specified terminals to allow the breaker to reset.

If the 16 contact inputs available, four have functions already assigned to them (preset) and cannot be changed, the other 12 are user-configurable. The Preset Contact Inputs are:

- External Emergency Shutdown
- External Reset
- Raise Speed Setpoint
- Lower Speed Setpoint

Before starting, the External Emergency Shutdown contact must have an external switch wired in and closed or be jumpered closed. The control will initiate an emergency shutdown any time the contact is opened. This input is typically tied into the system's trip string and provides trip feedback to the control.

The external reset contact can be used to remotely clear alarms and return the control to the (Controlling Parameter/Push Run or Prgm) state after a shutdown.

The raise and lower speed setpoint contact inputs can be used to remotely raise and lower speed or load.

Applications requiring external contact inputs must have the desired function assigned or configured to a specific input. There is a choice of twelve possible contact inputs and twenty-seven programmable functions. If the 505 is configured for a generator application two of the contacts must be configured for the Generator and Utility breaker inputs. The Generator Breaker contact must be wired so it is closed when the generator breaker is closed. The Utility Tie Breaker contact must be wired so it is closed when the utility tie breaker is closed.

Refer to Chapter 4 of this manual for a complete list of programmable contact input functions.

Analog Inputs

Analog inputs # 1, 2, 3, 4, and 5 may be used with two-wire ungrounded (loop powered) transducers or isolated (self-powered) transducers. Jumpers are available to match the analog input circuit to the transducer being interfaced with, or the power supply common may be jumpered on the terminal block. Verification of jumper location is recommended before system startup or operation. See Table 2-1 for jumper options and Figure 2-4 for jumper locations.

Because inputs 1-5 are not fully isolated, care must be taken in their application and maintenance to avoid "ground-loop" type problems. If interfacing to a non-isolated device with one of these inputs, the use of a loop isolator is recommended to break any return current paths, which could result in erroneous readings.

Analog input # 6 is a fully isolated input and is designed to be used with a non-isolated source such as a Distributed Control System (DCS). This input does not use or have jumpers for hardware configuration options. Refer to Figure 2-7, Option #1 for correct wiring configuration.

All six analog inputs are programmable, and have an input impedance of 200 Ω . Refer to Chapter 4 of this manual for a complete list of programmable analog input options.

Analog Outputs

Applications using a 505 current output must have the desired analog value assigned or configured to a specific output. There is a choice of six possible 4–20 mA output drivers of which to use to display a parameter externally. Optionally, if Actuator Driver #2 is not being utilized to drive an actuator, it can be programmed to function as a 4–20 mA driver to display one of the values listed below. The analog output connections for the 505 are shown in Figure 2-7. All 505 analog outputs can drive into a maximum of 600 Ω .

Refer to Chapter 4 of this manual for a complete list of programmable analog output options.

Actuator Outputs

Two actuator outputs are available and programmable to interface with Woodward Governor Company actuators (20–160 mA drive currents) or non-Woodward actuators (4–20 mA drive currents).

Each actuator output can be individually configured to interface with Woodward or non-Woodward type actuators. Actuator drive current is selected in the Program Mode. Maximum impedance for each 4 to 20 mA actuator output driver is 360 Ω (actuator impedance + wire resistance). Maximum impedance for each 20 to 160 mA actuator output is 45 Ω (actuator impedance + wire resistance). Dither is available for either output.

Each actuator driver senses the drive current to allow over- and under-current shutdowns. The 505 can be configured to use one or two actuators. If only one actuator is used and programmed, it must be wired to actuator #1's output terminals. If two actuators are used they can be programmed to operate in a staggered or parallel mode. If the "Actuator #2 Offset" percentage is set to 50% then actuator #2 will begin opening when actuator #1 reaches 50%. The control will continue to open both valves to 100% with a position difference of 50%. To operate the two actuators in parallel set "Actuator #2 Offset" percentage to zero. This will force both actuators to operate at the same level or in parallel.

Optionally, if actuator #2 driver is not used as an actuator output driver it can be used as a 4–20 mA current output to drive a meter or DCS input. Refer to Chapter 4 of this manual for a complete list of programmable analog output options.

In addition, an eleven (11) point actuator linearization adjustment curve is available through the Service Mode for each actuator output (see Service Mode adjustments in volume 2).

Relay Outputs

There are eight relay outputs available from the 505. All relay contacts are Form C type contacts.

For relay load ratings, refer to Appendix A in Volume 2.

**NOTE**

Before installation verify that the 505's relay contacts meet the power requirements of the circuit with which it is being interfaced. Interposing relays are required, in cases where the interfaced circuit demands relay contacts with a higher power rating. If interposing relays are required, it is recommended that interposing relays with surge (inductive kick-back) protection be used. Improper connection could cause serious equipment damage.

Two of the eight relay outputs available are dedicated to a function and are as follows:

- Alarm relay—energizes for any alarm condition
- Shutdown relay—de-energizes for any shutdown condition

The remaining six relays can be programmed to energize upon a function change of state or an analog value level. Applications requiring programmable relay outputs must have the desired switch condition, or specific analog value assigned to them. Refer to Chapter 4 of this manual for a complete list of programmable relay output options.

Serial Communications

There are three serial communications ports on the 505. Ports one and two are for Modbus communications and can be configured for RS-232, RS-422, or RS-485 communications. Figures 2-10, 11, and 12, show the communications port connections for ports #1, and #2. Ports one and two are accessed through terminal blocks located on the 505's back side. RS-422 and RS-485 communication lines can function up to a length of 4000 feet Refer to the Modbus section of this manual for a list of all the commands and parameters available through ports one and two. The third port, utilizing a 9-pin Sub-D connector, is dedicated for uploading and downloading unit configuration values at the factory.

The Program Mode can not be accessed through the communication ports. Program configuration must be done from the keypad on the front of the control.

Modbus Wiring

The 505 control can communicate to two devices via RS-232, RS-422, RS-485 using an ASCII or RTU Modbus transmission protocol. The communications port is brought out to terminal blocks for wiring. Each communications mode is wired to different terminals. The following sections identify the terminal landings required for each mode.

RS-232 Wiring

A RS-232 link is limited to a distance of 50 feet. The 505 control utilizes terminal blocks 114-117 and 106-109 for RS-232 connections. Figure 2-10 shows typical RS-232 communications connection. The transmit data (TXD), receive data (RXD), and signal ground (SIG GND) must be properly connected as shown. In addition the shield (SHLD) should be connected in at least one location..

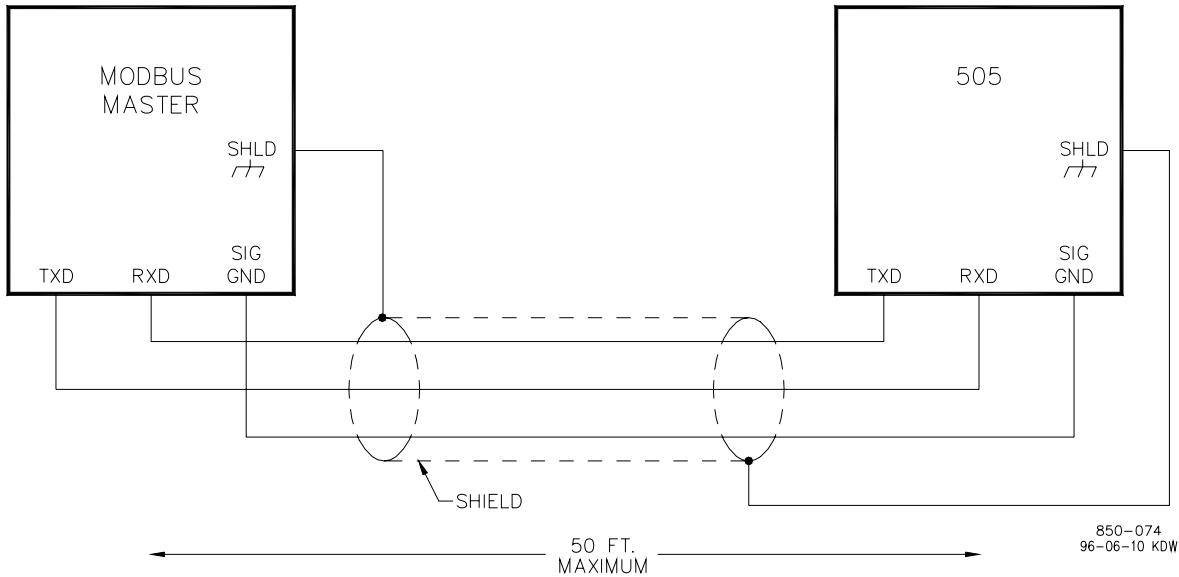

Figure 2-10. Typical RS-232 Communications

RS-422 Wiring

An advantage of RS-422 communications is that it uses a differential voltage and can accommodate much longer transmission distances. A RS-422 link can communicate up to a distance of 4000 feet. The 505 control utilizes terminal blocks 108-113 and 116-121 for RS-422 connections. Figure 2-11 shows a typical RS-422 communications connection. The transmit data pairs (422T+ and 422T-), receive data pairs (422R+ and 422R-), and signal ground (SIG GND) must be properly connected as shown. In addition, the shield (SHLD) should be connected in at least one location. The last unit in the Modbus network chain, and only the last unit, should have its receiver terminated with a resistor. The 505 control has termination resistors built-in. See the jumper option chart (Table 2-1) to connect the termination resistor..

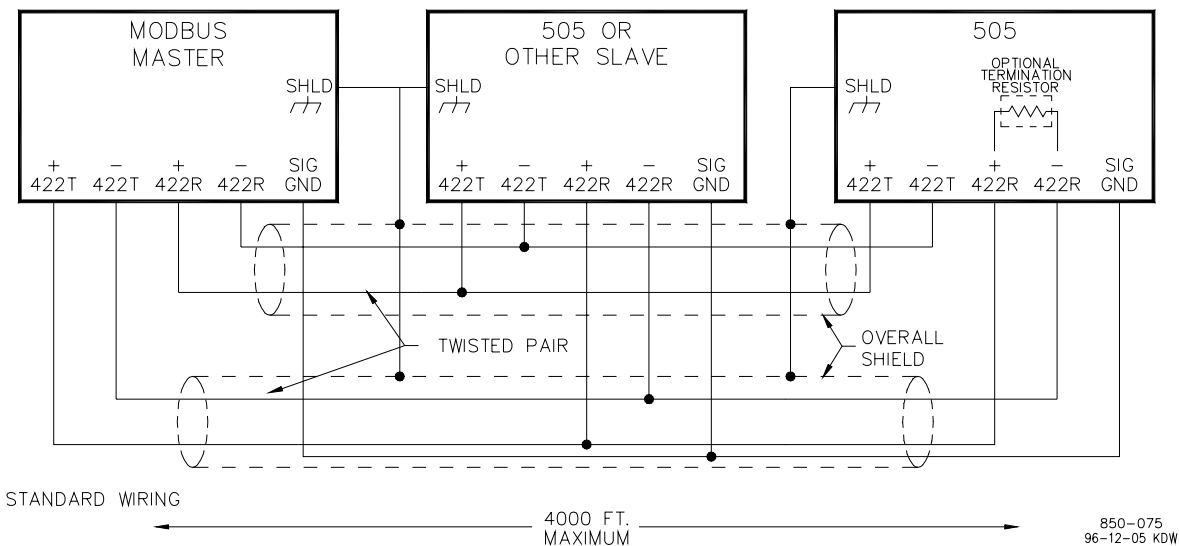

Figure 2-11. Typical RS-422 Communications

RS-485 Wiring

RS-485 communications can also accommodate transmission distances of up to a distance of 4000 feet. The 505 control utilizes terminal blocks 108-111 and 116-119 for RS-485 connections. Figure 2-12 shows a typical RS-485 communications connection. The data lines (422R+/485+ and 422R-/485-) and signal ground (SIG GND) must be properly connected as shown. In addition, the shield (SHLD) should be connected in at least one location. The last unit in the Modbus network chain, and only the last unit, should have its receiver terminated with a resistor. The 505 control has termination resistors built-in. See the jumper option chart (Table 2-1) to connect the termination resistor.

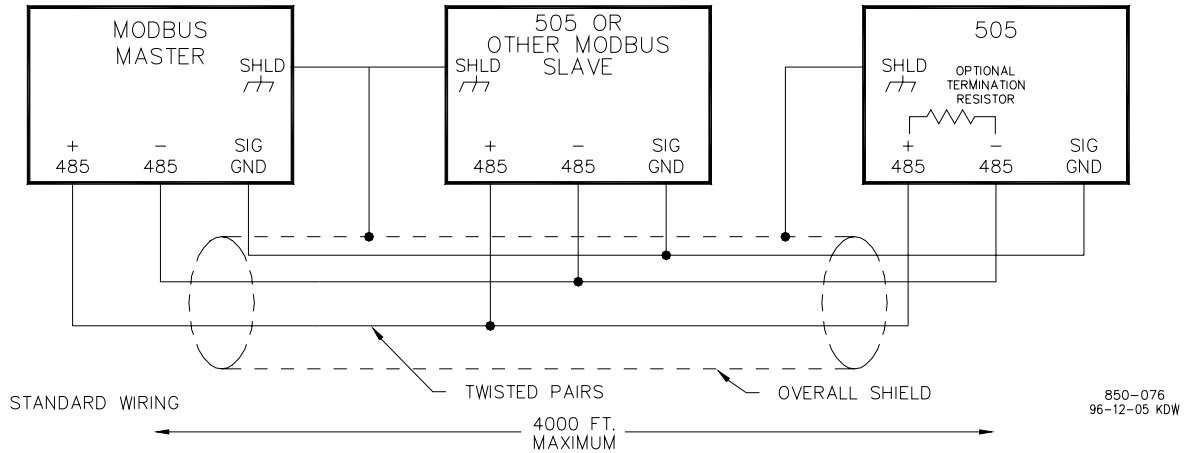

Figure 2-12. Typical RS-485 Communications

Communications Grounding and Shielding

All three 505 communications ports are fully isolated from earth ground. The RS-422 and RS-485 specifications state that a ground wire is needed if there is no other ground path between units. the preferred method to do this for isolated ports is to include a separate wire in the ground cable that connects the circuit grounds together. Connect the shield to earth ground in at least one location, see Figure 2-13.

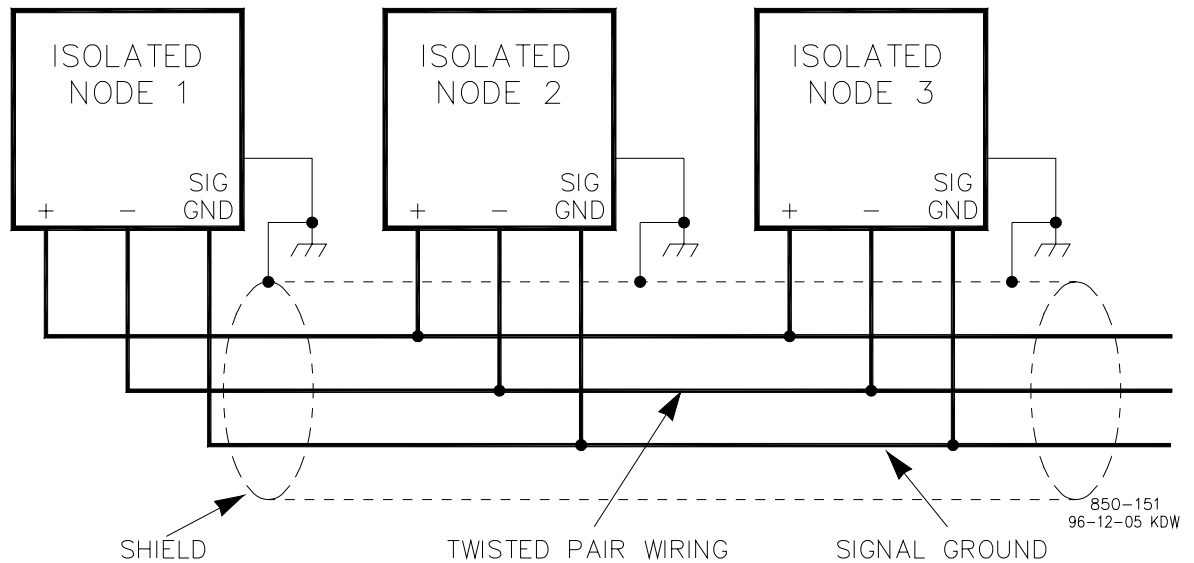

Figure 2-13. Preferred Multipoint Wiring with a Separate Signal Ground Wire

Non-isolated nodes may not have a signal ground available. If signal ground is not available, use the alternate wiring scheme as shown in Figure 2-14. The alternate way is to connect all circuit grounds of isolated nodes to the shield, and then connect the shield to earth ground at a non-isolated node.

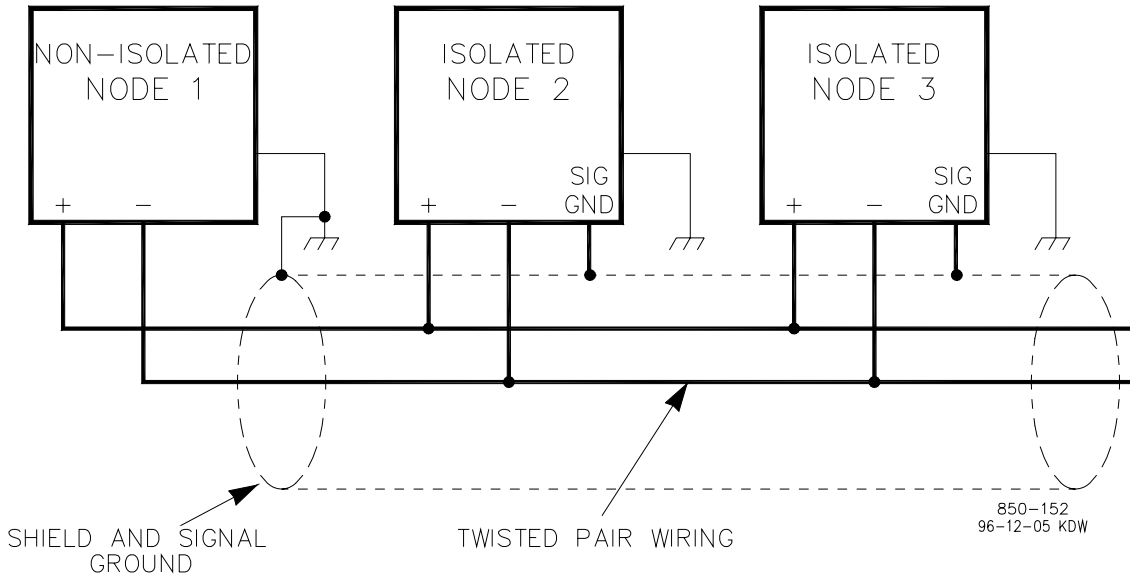

Figure 2-14. Alternate Multipoint Wiring without a Separate Signal Ground Wire

Chapter 3. 505 Control Description

Introduction

The 505 uses a digital Low Signal Select (LSS) bus to allow the lowest of three signals to position the turbine's governor valve. The three signals available to control governor valve position, are a Speed PID output, a programmable Auxiliary PID output, and a valve limiter output. The output of the LSS directly sets the actuator output current.

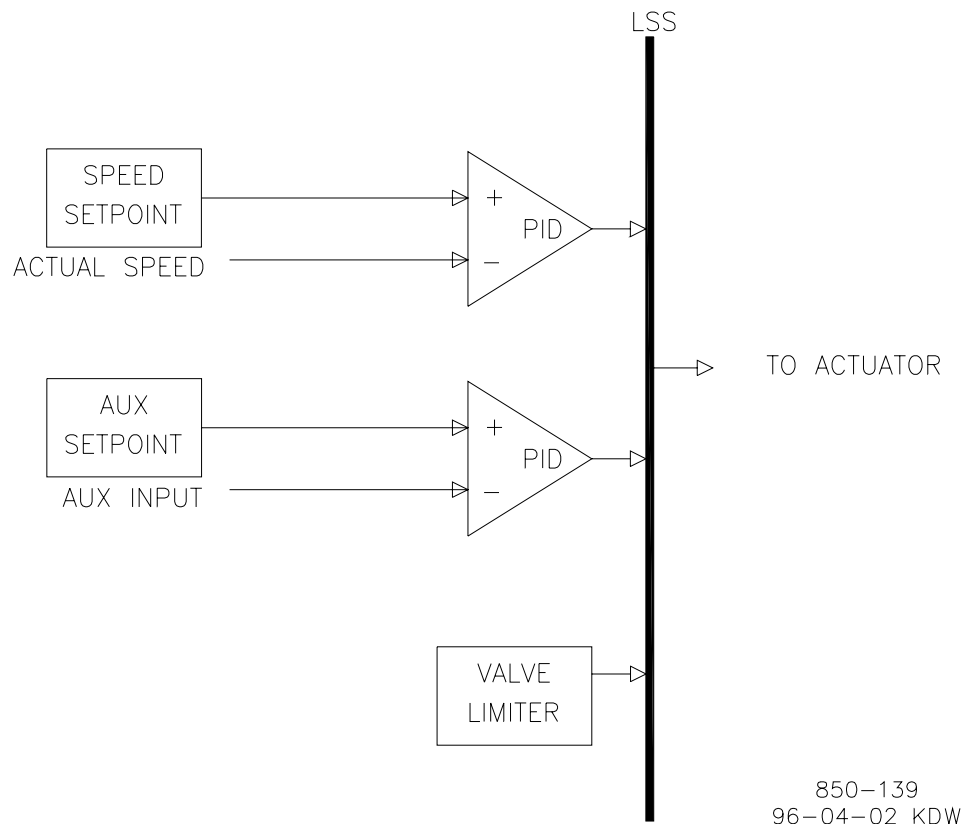

Figure 3-1. Basic Control Overview

Turbine Start

The 505 has three turbine start modes (manual, semi-automatic or automatic) from which to choose from. One of these start modes must be chosen and programmed to perform a system startup. Once a 'RUN' command is issued, the speed setpoint and valve limiter are manipulated automatically by the 505 or manually by the operator, depending on which start mode is selected. After a turbine start has been completed, turbine speed will be controlled at a minimum controlling speed. The minimum controlling speed may be idle if idle/rated is being used, low idle if the auto start sequence is used, or minimum governor if neither idle/rated or auto start sequence is used.

A 'RUN' command may be issued from the 505 keypad, an external contact, or through Modbus communications. If an 'External Run' contact is programmed, a 'RUN' command is issued when the contact is closed. If the contact is closed prior to start-up it must be opened and re-closed to issue a 'RUN' command.

If turbine speed is sensed when a 'RUN' command is issued, the control will instantly match the speed setpoint to the sensed speed and continue towards the minimum controlling speed. In the event the sensed turbine speed is greater than the minimum controlling speed setting, the speed setpoint will match this sensed speed, the Speed PID will control at this point, and the control will wait for further action to be taken by the operator (unless auto start sequence is configured). If the turbine speed is first sensed within a critical speed avoidance band when 'Run' is selected, the speed setpoint will match the actual speed and increase to the upper end of the critical avoidance band and wait for action to be taken by the operator.

Start Permissive

An external contact may be used as a turbine startup permissive. When programmed for this functionality, the contact input must be closed in order for a 'RUN' command to be executed. Should the contact be open when a 'RUN' command is given, an alarm will be issued and the 505 display will indicate that the start permissive was not met (Start Perm Not Met). The alarm does not need to be cleared but the contact must be closed before the 505 will accept the 'RUN' command. After 'RUN' has been accepted, the start permissive contact will have no effect on operation. If used, this input is typically connected to a Trip & Throttle valve's closed limit switch to verify that it is in the closed position before a turbine startup is performed.

Zero Speed Signal Override

The 505 issues a shutdown if no speed signal is detected (magnetic pickup voltage less than 1 Vrms or speed is less than the 'Failed Speed Level'). To allow the control to start with speed not being sensed, this shutdown logic must be overridden. The control can be configured to provide a manual or an automatic speed override. For added protection, a timed limit on the override is available. The status of the MPU override logic may be viewed in the Service mode or through Modbus communications. The override logic applies to both passive and active speed probes.

Manual Speed Override

If the 'Override MPU Fault' function is assigned to a contact input, the loss-of-speed detection logic is overridden as long as this contact is closed; until the maximum time expires. Opening the assigned contact input, disables the override logic, and re-arms the loss-of-speed detection circuit. Once re-armed, a system shutdown is executed if the sensed speed drops below the 'Failed Speed Level' setting.

A maximum override time limit is provided as an extra level of protection, in the event the contact input is left closed. A ten minute maximum time limit is applied to a Manual override command (as defaulted in the Service Mode). This time starts when the RUN command is initiated and re-arms the loss-of-speed detection when the time expires. The 505 will execute a system shutdown if turbine speed isn't above the 'Failed Speed Level' setting when the time expires.

Automatic Speed Override

If the Manual Speed Override option is not programmed, the Automatic Speed Override logic is used by the 505 to override the loss-of-speed signal shutdown during a turbine startup. With the Automatic Override logic, the loss-of-speed signal failure is armed when the turbine trips and remains armed until the sensed turbine speed exceeds the programmed ('Failed Speed Level' setting + 250 rpm). Once turbine speed exceeds this level, the loss of speed detection circuit is re-armed and the control will execute a system shutdown if sensed speed drops below the 'Failed Speed Level' setting.

For added protection, a timed limit is available on the automatic speed override function. The timed speed override timer deactivates the loss-of-speed override logic after the programmed time expires. If programmed, this timer starts counting down once a 'RUN' command has been issued. This timer when programmed provides an extra level of protection, in the event both speed input probes are failed when the unit is started. This timer may be programmed in the 505's Service mode.

Turbine Start Modes

Manual Start Mode

The following startup procedure is employed when the Manual start mode is configured:

1. Issue a RESET command (to reset all alarms and shutdowns)
2. Issue a RUN command (verify T&T valve is closed before issuing)
 - At this point the 505 will ramp open the governor valve to its maximum position at the 'Valve Limiter Rate'.
 - The speed setpoint will ramp from zero to the minimum controlling speed setting at the 'Rate To Min' rate.
3. Open Trip & Throttle valve at a controlled rate
 - When turbine speed increases to the minimum controlling speed, the 505's Speed PID will take control of turbine speed by controlling turbine inlet valve position.
4. Open Trip & Throttle valve to 100%
 - Speed remains controlled at the minimum controlling point until action is taken by the operator or the 'Auto Start Sequence', if programmed, begins controlling.

The 'Limiter Max Limit', 'Valve Limiter Rate' and 'Rate To Min' settings are tunable in the Service mode.



WARNING

The trip-and-throttle valve must be closed before pushing the 'RUN' key in Manual Start mode. If a RUN command is given while the trip- and-throttle valve is open, there exists a possibility of turbine runaway with resultant serious injury or loss of life.

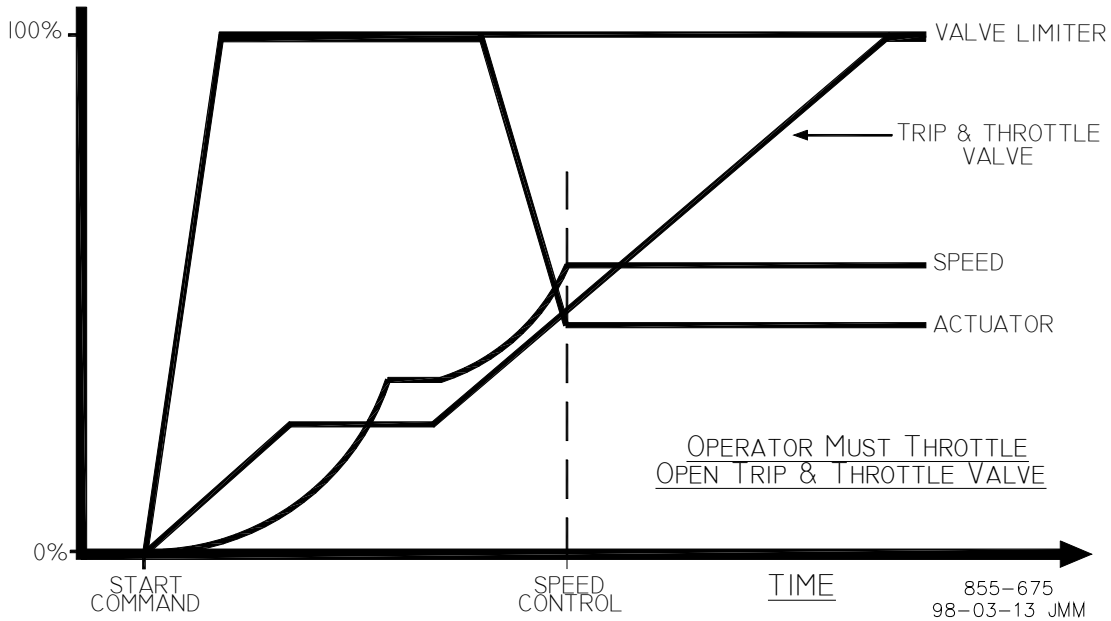

Figure 3-2. Manual Start Mode Example

Semiautomatic Start Mode

The following startup procedure is employed when the Semiautomatic start mode is configured:

1. Issue a RESET command (to reset all alarms and shutdowns)
2. Open the Trip & Throttle valve (verify that the turbine does not accelerate)
3. Issue a RUN command
 - At this point the speed setpoint will ramp from zero to the minimum controlling speed setting at the 'Rate to Min' rate.
4. Raise the 505's VALVE LIMITER at a controlled rate.
 - When turbine speed increases to the minimum controlling speed, the 505's Speed PID will take control of turbine speed by controlling turbine inlet valve position.
5. Raise the 505's VALVE LIMITER to 100%.
 - Speed remains controlled at the minimum controlling point until action is taken by the operator or the 'AUTO START SEQUENCE', if programmed, begins controlling.

The valve limiter will open at the 'Valve Limiter Rate' and may be moved using the 505 keypad, external contacts or Modbus communications. The 'Limiter Max Limit', 'Valve Limiter Rate' and 'Rate To Min' settings are tunable in the Service mode.

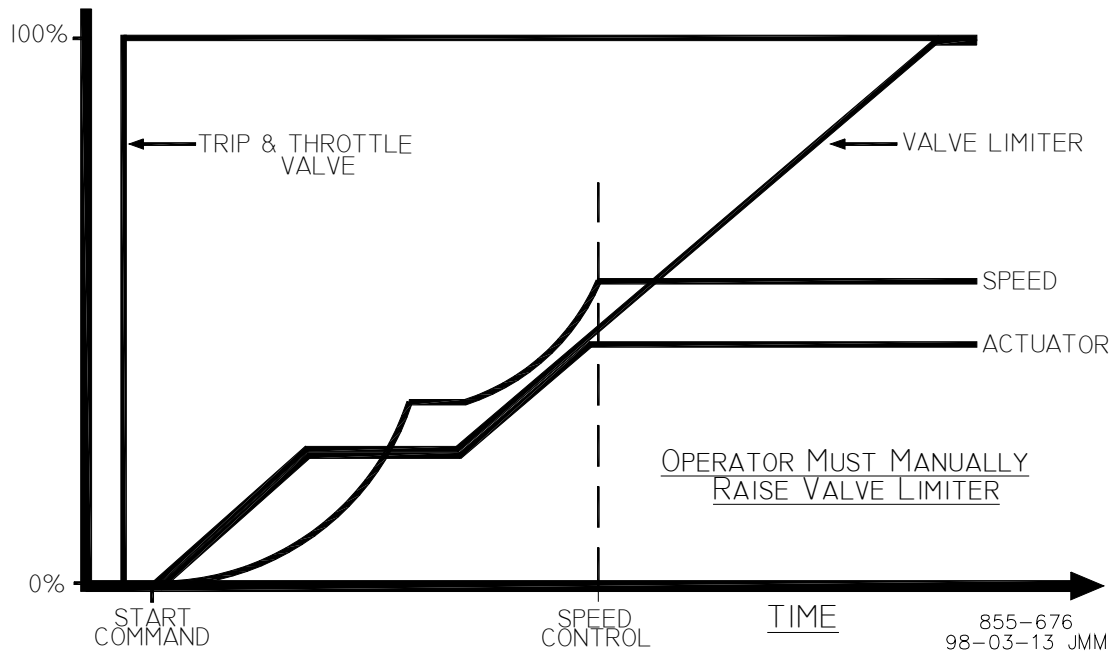

Figure 3-3. Semiautomatic Start mode Example

Automatic Start Mode

The following startup procedure is employed when the Automatic start mode is configured:

1. Issue a RESET command (to reset all alarms and shutdowns)
2. Open the Trip & Throttle valve (verify that the turbine does not accelerate)
3. Issue a RUN command
 - At this point the 505 will ramp open the governor valve to its maximum position at the 'Valve Limiter Rate' setting.
 - The speed setpoint will ramp to the minimum controlling speed setting at the 'Rate to MIN' rate.
 - When turbine speed increases and matches the ramping speed setpoint, the 505's Speed PID will take control of turbine speed by controlling turbine inlet valve position.
 - Speed remains controlled at the minimum controlling point until action is taken by the operator or the 'Auto Start Sequence', if programmed, begins controlling.

The 'Limiter Max Limit', 'Valve Limiter Rate' and 'Rate To Min' settings are tunable in the Service mode. The automatic start routine may be aborted at any time by issuing valve limiter raise or lower commands, or an emergency shutdown.

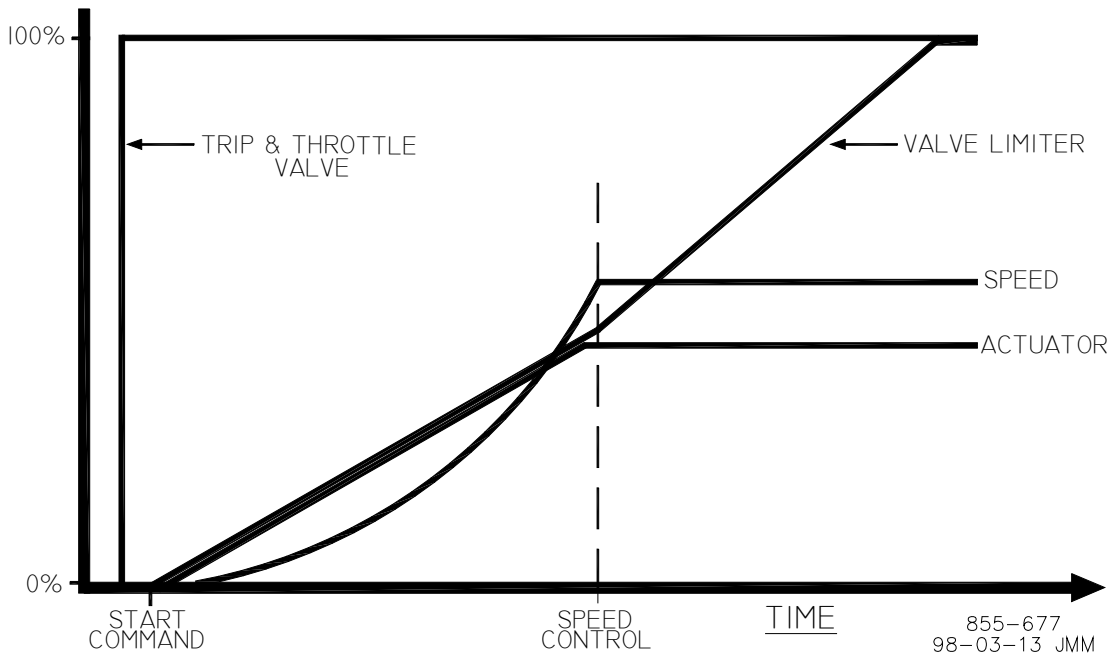

Figure 3-4. Automatic Start Mode Example

Critical Speed Avoidance

In many turbines, it is desirable to avoid certain speeds or speed ranges (or pass through them as quickly as possible) due to excessive turbine vibration or other factors. During programming, two critical speed ranges may be configured. The Idle/Rated or Auto Start Sequence function must be programmed to perform critical speed avoidance.

The speed setpoint cannot be stopped in the critical band. If a Raise/Lower Speed Setpoint command is issued while in a critical band, the speed setpoint will ramp up or down (depending on raise or lower command) to the extent of the critical range. Since the lower speed setpoint has priority over a raise setpoint, issuing a lower command while increasing through the band will reverse the setpoint direction and return it to the lower limit of the band. If a lower speed setpoint command is given while in a critical band, turbine speed must reach the bottom of the band before another command can be executed.

A speed setpoint value cannot be directly entered (with the ENTER key) within the programmed critical speed band settings. In the event this is attempted, an error message will appear on the 505 front panel display.

If another controlling parameter, besides the Speed PID, drives the turbine's speed into a critical band for longer than five seconds, the speed setpoint will instantly go to the idle setting and an alarm will occur (Stuck in Critical).

During a startup routine if the Speed PID cannot accelerate the unit through a programmed band within a calculated length of time, a "Stuck in Critical" alarm will be issued and the speed setpoint will instantly return to idle. The "calculated length of time" is a value of five times the length of time it should normally take to accelerate through the band (based on the "Critical Speed Rate" setting). If the "Stuck in Critical" alarm occurs on a regular basis, it may be indicating that the "Critical Speed Rate" is set too fast for the turbine to respond to.

Critical speed bands are defined in the Program mode under the SPEED SETPOINT VALUES header. All critical speed band settings must be set below the 'Min Governor Speed Setpoint'. A configure error will occur if an idle setpoint is programmed within a critical speed band. The rate in which the speed setpoint moves through a critical speed band is set by the 'Critical Speed Rate' setting. The 'Critical Speed Rate' setting should be set at but no higher than the turbine's rated maximum acceleration rate.

Idle/Rated

The 505 is equipped with an Idle/Rated function which allows the 505 to automatically ramp turbine speed to the application's Rated speed setting. When deselected, the turbine speed ramps down to the application's Idle speed setting (as defaulted in the Service Mode).

The Idle/Rated function can be used with any 505 start mode (manual, semiautomatic, automatic). When a RUN command is issued, the speed setpoint will ramp from zero rpm up to and hold at the 'Idle Setpt' setting. When a ramp-to-rated command is given, the speed setpoint ramps to the 'Rated Setpt' setting at the 'Idle/Rated Rate'. While ramping to a Rated speed, the setpoint can be stopped by a raise or lower speed command or a valid entered speed setpoint.

The 505 will inhibit a ramp-to-idle speed or ramp-to-rated speed command, if the Generator Breaker is closed, Remote Speed Setpoint is enabled, Cascade PID is in control, or the Auxiliary PID is in control (as defaulted in the Service Mode). Alternatively, the 505's 'Idle Priority' and 'Use Ramp to Idle Function' Service mode settings can be configured to change the defaulted idle/rated logic.

Ramp to Rated Feature

The Idle/Rated function can be changed to a "Ramp to Rated" function (see Service Mode). With this configuration, the speed setpoint holds at the idle speed setting until a Ramp-to-Rated command is given. Upon command the speed setpoint will accelerate to the Rated speed setpoint, however, it will not ramp back to the idle speed setting. When Rated is de-selected, the speed setpoint stops as opposed to returning to Idle. When this configuration is used, there is no Ramp-to-Idle option; it is not used.

If Rated is de-selected while in a critical speed avoidance band (using Ramp to Rated only feature), the speed setpoint will stop at the top end of the avoidance band. If the Ramp to Rated function is stopped/halted using a raise or lower speed setpoint command, the setpoint will continue to the upper limit of the band if a Raise command was used or will reverse direction to the lower limit of the band if a Lower command was used.

If Idle is selected while in a critical speed avoidance band (not using Ramp to Rated only feature), the speed setpoint will return to the Idle setpoint, continuing to move at the critical avoidance rate while within the band. The speed setpoint cannot be stopped within a critical speed avoidance band. Attempting to stop the ramp to rated while in a critical band will continue the speed setpoint to the upper limit of the band if a Raise command was used or will reverse direction to the lower limit of the band if a Lower command was used.

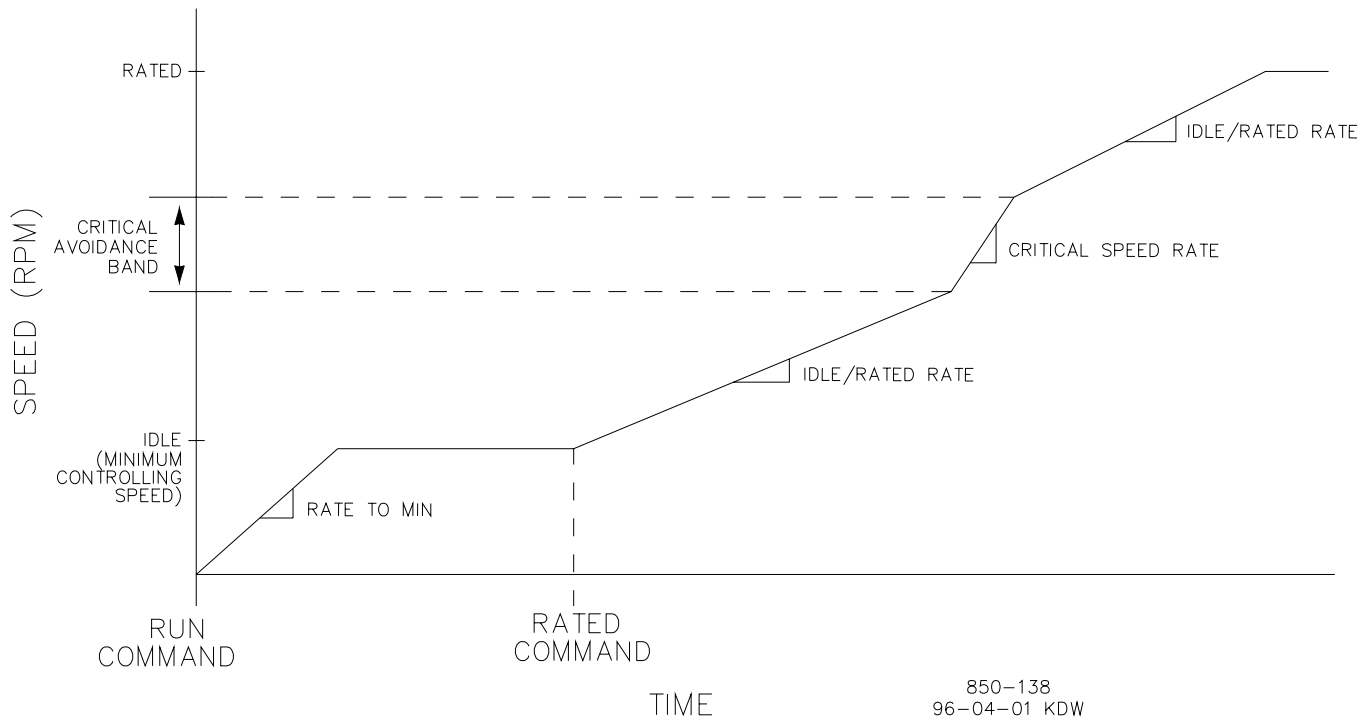

Figure 3-5. Idle/Rated Start

A Ramp-to-Idle speed or Ramp-to-Rated speed command may be selected from the 505 keypad, contact input, or Modbus communications. The last command given from any of these three sources dictates the function performed.

If a 505 contact input is programmed to select between Idle or Rated speeds, Idle speed is selected when the contact is open and rated speed is selected when it is closed. The Idle/Rated contact can be either open or closed when a trip condition is cleared. If the contact is open, it must be closed to initiate a Ramp-to-Rated speed. If the contact is closed, it must be opened and re-closed to initiate a Ramp-to-Rated speed.

When the turbine is used for mechanical drive applications, rated speed may be set at the minimum governor speed setting. When the turbine is used to drive a generator, the 'rated speed' setting may be set at or between the minimum governor and synchronous speed settings.

All pertinent Idle/Rated parameters are available through the Modbus links, refer to Chapter 6 for a complete listing.

Automatic Start Sequence



NOTE

This function is not the same as the 'AUTOMATIC START MODE'. The Automatic Start Sequence can be used with any one of the three start modes.

The 505 can be configured to utilize an Automatic Start Sequence to start the turbine. This sequencing logic allows the 505 to perform a complete controlled system startup from zero speed to rated speed. With this function, the turbine's starting ramp rates and idle speed hold times depend on the length of time the unit was shutdown. This sequence logic may be used with any of the three start modes (manual, semiautomatic, automatic), and is initiated by a 'RUN' command.

With this function, when a 'RUN' command is given, the Automatic Start Sequence ramps the speed setpoint to a low idle setpoint, holds at this setting for a duration, ramps the speed setpoint to a high idle setpoint, holds at this setting for a duration, then ramps the speed setpoint to a rated speed setting. All ramp rates and hold times are programmable for both hot start and cold start conditions. The control differentiates between hot and cold starts by using a hours-since-trip timer. This timer starts when a shutdown has been executed and turbine speed has decreased below the low idle speed setting.

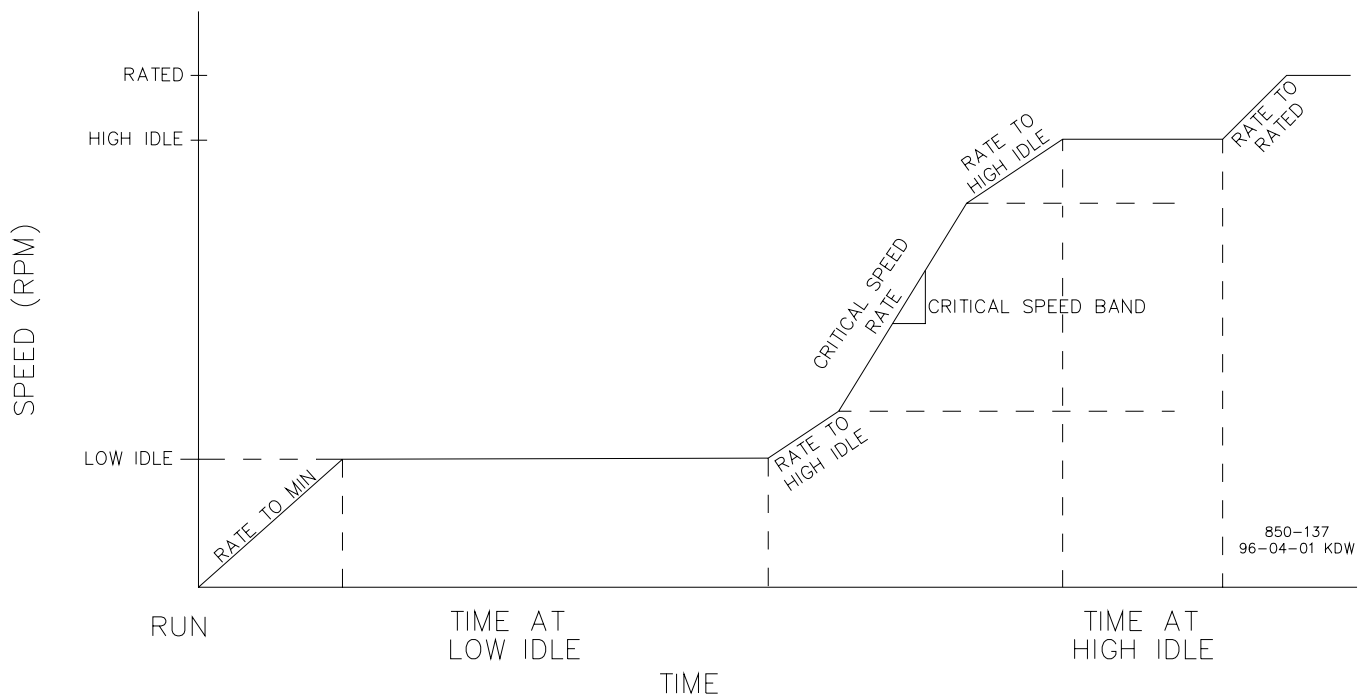

Figure 3-6. Automatic Start Sequence

With this sequence, a set of hot-start ramp rates and hold times is programmed for use when a 'RUN' command is given and the turbine has been shutdown for less than the programmed 'HOT START' time setting. A set of cold-start ramp rates and hold times is also programmed for use when a 'RUN' command is given and the turbine has been shutdown for longer than the programmed 'COLD START' time setting.

If a turbine 'RUN' command is given when the length of time the system has been shutdown is between the 'HOT START' and 'COLD START' time settings, the control will interpolate between the hot and cold programmed start values to determine starting rates and hold times.

For example, if the unit had the following Automatic Start Sequence settings:

COLD START (> xx HRS)	= 22	HRS
HOT START (< xx HRS)	= 2	HRS
LOW IDLE SETPT	= 1000	rpm
LOW IDLE DELAY (COLD)	= 30	MIN
LOW IDLE DELAY (HOT)	= 10	MIN
HI IDLE SETPT	= 2000	rpm
RATE TO HI IDLE (COLD)	= 5	rpm/sec
RATE TO HI IDLE (HOT)	= 15	rpm/sec
HI IDLE DELAY TIME (COLD)	= 20	MIN
HI IDLE DELAY TIME (HOT)	= 30	MIN
RATE TO RATED (COLD)	= 10	rpm/sec
RATE TO RATED (HOT)	= 20	rpm/sec
RATED SETPT	= 3400	rpm

If the unit was tripped for 12 hours, the 505 would interpolate between the Hot and Cold parameters and use the following rates and delays (viewed in the Service Mode):

LOW IDLE DELAY	= 20	MIN
RATE TO HI IDLE	= 10	rpm/sec
HI IDLE DELAY	= 10	MIN
RATE TO RATED	= 15	rpm/sec
HOURS SINCE TRIP	= 12	HOURS

Based on the example's configuration and trip time, the speed setpoint would ramp to 1000 rpm at the 'Rate to Min' setting and hold for 20 minutes, move to 2000 rpm at 10 rpm/sec and hold there for 10 minutes, and lastly, move to 3400 at 15 rpm/sec. At 3400 rpm, the sequence would be completed.

If the unit was tripped for 2 hours or less and restarted, the 505 would use the Hot Start parameters. If the unit was tripped for 22 hours or longer and restarted, the 505 would use the Cold Start parameters. . The 'Hours since Trip' timer starts counting when the unit shuts down and the speed has coasted down below the low idle speed setting.



NOTE

The 505 will automatically set the hours-since-trip timer to its maximum setting of 200 hours to ensure a cold start is selected after a power up or upon exiting the Program mode. The hours-since-trip timer will reset only when the turbine speed has increased above the minimum governor speed setting.

The Auto Start Sequence can be halted at any time from the 505 keypad, contact input or through Modbus. The sequence can be halted by a halt command, a raise or lower speed setpoint command, or when a speed setpoint is directly 'Entered' from the 505 keypad or through Modbus communications. When the sequence is halted, the delay timers do not stop if they have already started counting down. The sequence will resume when a 'Continue' command is issued. If there were 15 minutes remaining to hold at an idle speed and the Halt command was issued for 10 minutes before a issuing a Continue command, the sequence would remain at the idle speed for the remainder of the 'Hold Time'— which in this example is 5 minutes.

The halting and continuing of the Auto Start Sequence can be performed through the 505 keypad, contact input, or Modbus. The last command given from any of these three sources determines the mode of operation. However, a shutdown condition will disable this function, requiring it to be re-enabled after a start-up has been performed.

If a 505 contact input is programmed to function as an Halt/Continue command, the sequence is halted when the contact is open, and continued when the contact is closed. The Halt contact can be either open or closed when a Reset command is given. If the contact is closed, it must be opened to allow the sequence to be halted. If the contact is open, it must be closed and reopened to issue a halt command. Alternatively, a relay can be programmed to indicate when the Auto Start Sequence is halted.

An option is available to automatically halt the auto start sequence at the idle setpoints. This feature would result in the unit automatically stopping or halting at the low idle setpoint and at the high idle setpoint. If the unit is started and the speed is above the low idle setpoint, the sequence will initialize as halted. The sequence must be given a 'Continue' command once halted. The hold timers are still active with this option. If 'Continue' is selected and the hold timer has not expired, the sequence will remain in a timed wait until the hold timer has expired and then continue from that point.

When the 'Auto Halt at Idle Setpts' option is programmed, the Auto Start Sequence Continue contact input only requires a momentary closure to continue the sequence.

No Idle Programmed

If neither the Idle/Rated or Auto Start Sequence functions are programmed, the speed setpoint will ramp from zero to the minimum governor setpoint at the 'Rate To Min' setting rate. Critical speed bands cannot be programmed with this configuration.

Speed Control Overview

Turbine speed is sensed through one or two MPUs or proximity probes. The 'MPU Gear Ratio' and the 'Teeth Seen By MPU' settings are configured to allow the 505 to calculate actual turbine speed. One MPU and one proximity probe can be used at the same time, however, they must be mounted on the same gear since the 'gear ratio' and 'teeth seen by the MPU' must be the same for both inputs. The Speed PID (proportional, integral, derivative control amplifier) then compares this signal to the its setpoint to generate an output signal to the governor valve actuator (through a low signal select bus).



NOTE

The 505 is factory set (jumpers installed) to interface with passive MPUs, if proximity probes are used, the jumpers must be changed (see Chapter 2 for jumper options).

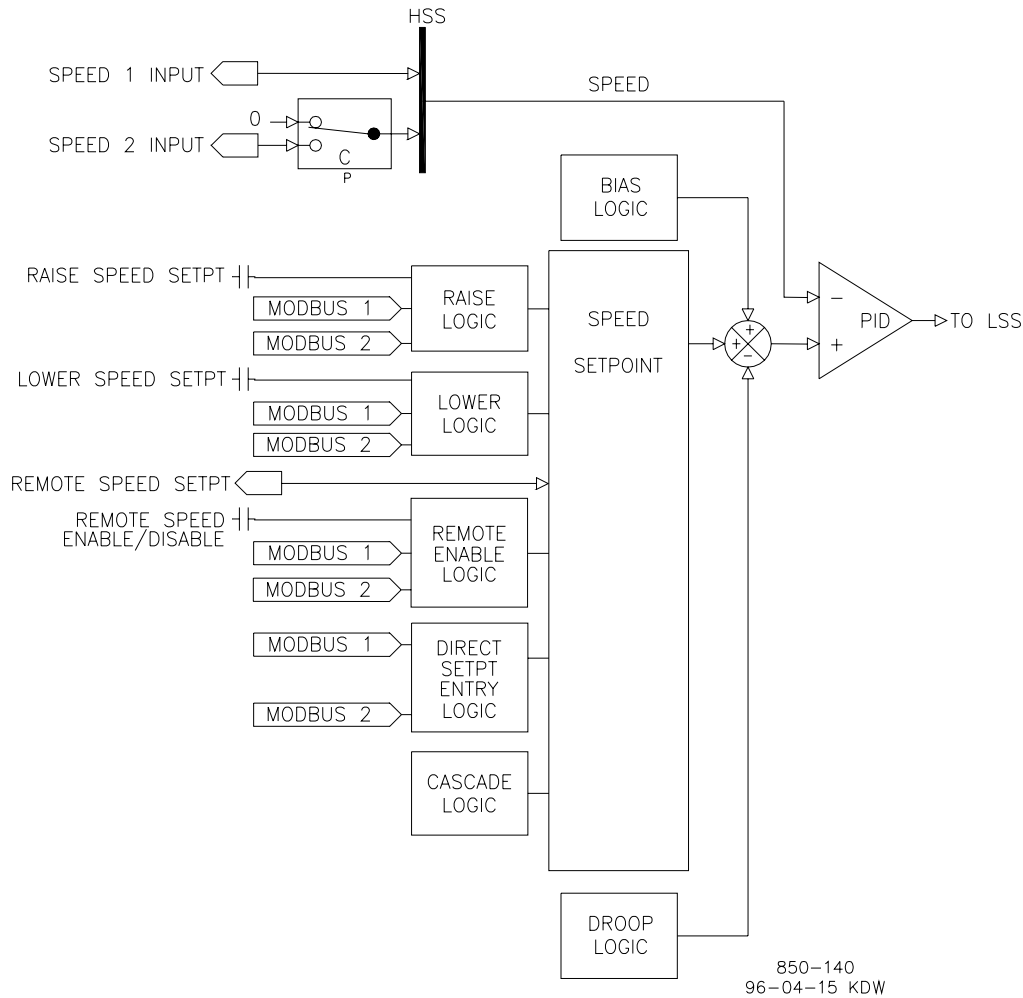

Figure 3-7. Speed Control Functional Diagram

Speed PID Operational Modes

The Speed PID operates in one of the following modes, depending on configuration and system conditions:

1. Speed Control
2. Frequency Control
3. Unit Load Control (droop)
 - Turbine inlet valve position (505 LSS position) control
 - Generator Load control

When not programmed for generator applications, the 505 Speed PID operates in a Speed control mode at all times. When programmed for generator applications, the state of the generator and utility tie breakers determine the operational mode of the Speed PID. When the Generator breaker contact is open, the Speed PID operates in a Speed control mode. When the generator breaker is closed and the utility tie breaker is open, the Frequency control mode is selected. When both the generator and utility tie breakers are closed, a Unit Load control mode is selected.

Speed Control

While in the Speed Control mode, the Speed PID will control a turbine at the same speed or frequency regardless of the load it is supplying (up to the unit's load capability). With this configuration, no form of droop or second controlling parameter is used by the PID for stability or control. Refer to Figure 3-6.

The following Speed PID mode descriptions are based on the 505 program's default settings. For information on how to change the 505's defaulted breaker logic, refer to Volume 2 of this manual. All pertinent speed control parameters are available through Modbus communications. See Chapter 6 for a list of all Modbus parameters.

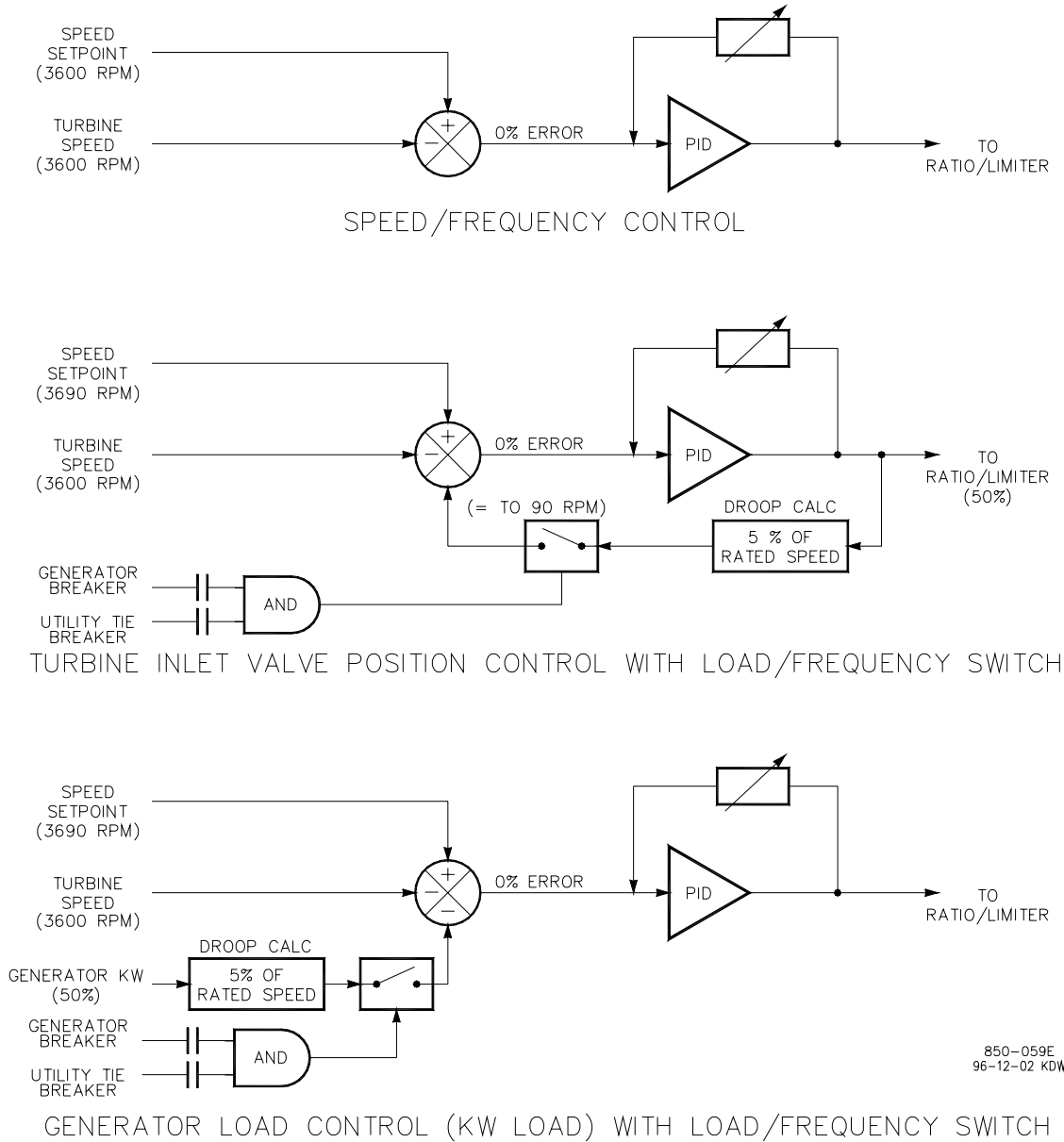

850-059E
96-12-02 KDW

Figure 3-8. Speed PID Control Modes

Frequency Control

The following Frequency Control mode descriptions are based on the 505 program's default settings. For information on how to change the 505's defaulted breaker logic, refer to Volume 2 of this manual.

The Speed PID operates in the Frequency control mode when the generator breaker is closed and the utility tie breaker is open. In the Frequency control mode, the unit will operate at the same speed or frequency regardless of the load it is supplying (up to the unit's load capability). Refer to Figure 3-5.

When breaker positions result in the Speed PID switching to Frequency control, the speed setpoint is instantly stepped to the last turbine speed (frequency) sensed before Frequency control was selected. This allows a bumpless transfer between modes. If the last speed sensed was not at the 'Rated Speed Setpoint' (synchronous speed) setting, the speed setpoint will ramp to the 'Rated Speed Setpoint' setting at a defaulted rate of 1 rpm/sec (tunable through the Service mode).

In the Frequency control mode the speed setpoint can be varied with the Speed Setpoint Raise/Lower commands, as desired, to allow manual synchronization across a tie breaker to an infinite bus. See the Synchronization section in this Chapter.

For indication purposes, a relay can be programmed to energize when the unit is in Frequency control.

Unit Load Control

The 505's Speed PID can control two independent parameters when the generator breaker is closed; frequency when the generator is isolated, and unit load when the generator is paralleled with an infinite bus. When the generator breaker and utility tie breaker inputs are both closed, the Speed PID operates in a Unit Load mode. This method of allowing a PID to control a second parameter is referred to as Droop.

Giving the Speed PID two parameters to control allows it to control unit load and act as a stabilizing effect for any change in bus frequency. With this configuration, when bus frequency decreases or increases, unit load increases and decreases respectively, based on the unit's droop setting. The net effect is a more stable bus. See Figure 3-6 for a frequency and load relationship diagram.

The term "droop" was derived from an isolated unit's speed reaction to an increase in load when another parameter (unit load) is fed back to a Speed PID's summing junction. The Droop term, as used throughout this manual refers to a PID's second controlling parameter. A second parameter representing unit load is fed back into the 505's Speed PID to allow it to control two parameters; speed when operating in an isolated mode, and unit load when paralleled to an infinite bus. See Figure 3-5.

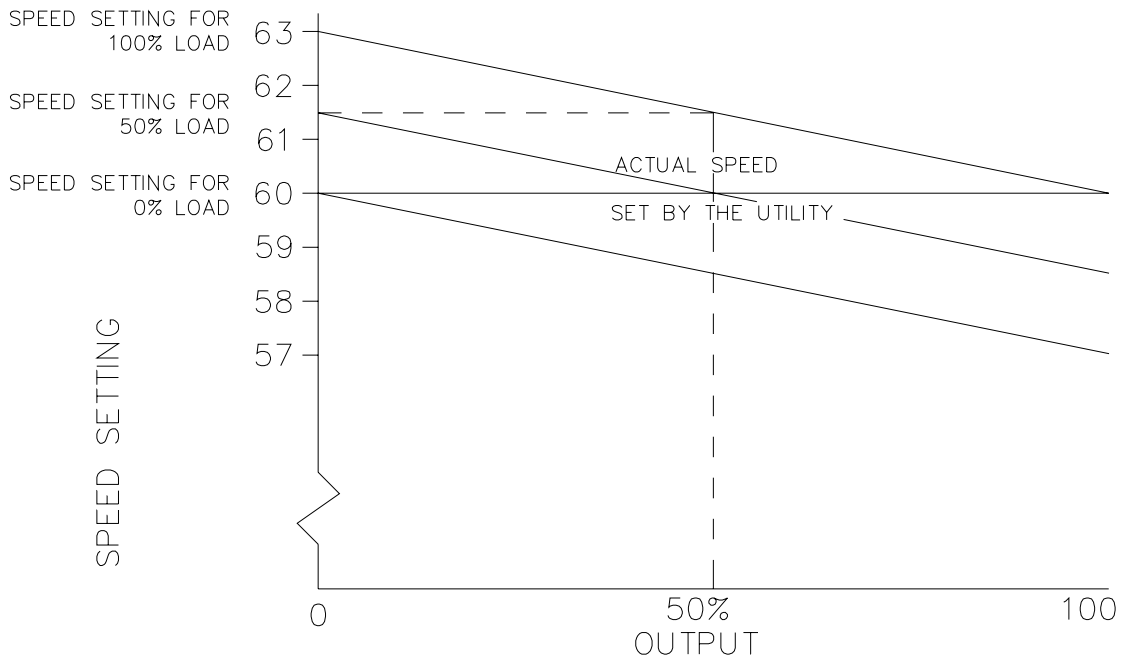

FREQUENCY/SPEED IS SET BY THE UTILITY GRID.
LOAD VARIES WITH SPEED SET POINT.

850-136
96-03-29 KDW

Figure 3-9. Frequency and Unit Load Relationship

Because the 505's Speed PID and setpoint are used to control turbine speed and a second parameter, this second parameter (unit load) is normalized to allow all three terms (speed, setpoint, unit load) to be summed together within the PID summing junction. This normalization is based on a percentage of rated speed and creates a direct relationship between unit load and the Speed PID's setpoint. Once unit load (0-100%) is represented as a percent of rated speed, the speed setpoint can be varied by this percent, above rated speed, to increase load from 0- 100% when paralleled to the utility. Unit load is converted to a percentage of rated speed as shown in the following example calculation:

$$\text{DROOP \%} \times (\text{gen load or valve position-\%}) \times \text{Rated Speed} = \text{Speed Setpoint change in rpm}$$

$$\text{Example: } 5\% \times 100\% \times 3600 \text{ rpm} = 180 \text{ rpm}$$

For this example when paralleled to a utility bus, the speed setpoint can be adjusted from 3600 rpm to 3780 rpm to vary unit load from 0 to 100%.

Drop feedback allows the Speed PID to control unit load (generator power or turbine valve position) once it is paralleled with a utility bus or other generating systems which do not have droop or loadsharing capability. When a turbine generator set is paralleled with a utility bus, the utility determines the unit frequency/speed, thus the governor must control another parameter. The 505 uses turbine inlet valve position (LSS bus position) or generator load as a second parameter to control when paralleled to an infinite bus.

It is recommended that a Woodward Real Power Sensor or equivalent watt transducer be used to sense generator load and feed it back to the 505's KW input for KW droop control. However, if KW droop is not used or programmed, the 505 uses its LSS bus position to represent or sense turbine inlet valve position when paralleled with an infinite bus. If while controlling generator load, the KW input signal fails the 505 will issue an alarm and revert to turbine inlet valve position to control from.

The generator load or turbine inlet valve position droop percentage cannot be set greater than 10%, and is typically set to 5%.

To configure the 505 for generator load control when paralleled to a infinite bus, program the 'KW DROOP' setting to 'YES', and program the 505 to accept an analog input from a Watt transducer sensing generator load.. To configure the 505 for turbine valve position control when paralleled to an infinite bus, program the KW DROOP setting to 'NO'. The generator load or turbine inlet valve position droop percentage cannot be set greater than 10%, and is typically set to 5%.

If the 505 is programmed to control unit load using turbine inlet valve position droop (LSS bus position), the 505 calculates load based on the valve position at the time the generator breaker was closed. This valve position is considered to be zero load. In a typical application where turbine inlet and exhaust pressures are at rated levels when the generator breaker is closed, this type of calculation allows unit load to be accurately sensed, and controlled.

However, in an application where turbine inlet or exhaust pressures are not at rated levels when the generator breaker is closed, the considered zero load level will be incorrect when system pressures do reach rated levels. With this type of application it is recommended that the Minimum Load setpoint not be used. To disable the use of the Minimum Load Setpoint, configure the 'Use Min Load' setting (under the Service mode's 'BREAKER LOGIC' header) to 'No'.

Speed Setpoint

The Speed PID's setpoint may be adjusted from the 505 keypad, external contacts, Modbus commands, or through a 4–20 mA analog input. A specific setpoint setting can also be directly entered through the 505 keypad or Modbus communications. The Cascade PID also directly controls this setpoint when it is used.

The Speed PID's setpoint may be adjusted a variety of ways. It can be adjusted up or down from the 505 keypad, external contacts, or through Modbus commands. It can be directly entered to a specific value from the 505 keypad or through Modbus commands. It can be remotely set by the Remote Speed Setpoint analog input or it can be manipulated by the Cascade controller to control the cascade input parameter.

The speed setpoint range must be defined in the program mode. Program settings 'Min Governor Speed Setpoint' and 'Max Governor Speed Setpoint' define the normal operating speed range of the turbine. The speed setpoint cannot be raised above 'Max Governor Speed Setpoint' setting unless an Overspeed Test is performed. Once the speed setpoint is taken above the 'Min Governor Speed Setpoint' setting, it cannot be varied below this setting again unless the Idle/Rated ramp-to-Idle command is selected or a Controlled Stop is selected.

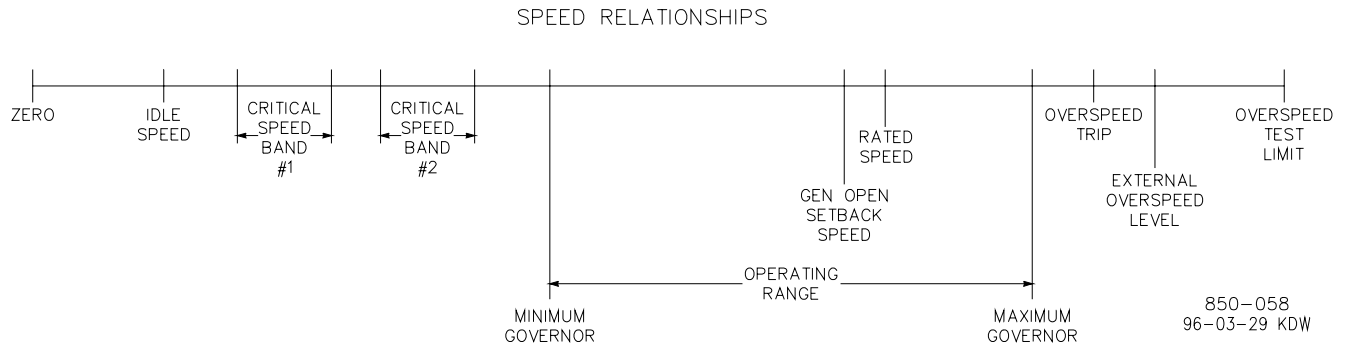

Figure 3-10. Speed Relationships

Once turbine speed is equal to or greater than the 'Min Governor Speed Setpoint' setting, the speed setpoint may be adjusted through discrete raise and lower commands. When a raise or lower speed command is issued, the setpoint moves at the programmed 'Speed Setpoint Slow Rate'. If a speed raise/lower command is selected for longer than three seconds, the speed setpoint will then move at the fast rate which is three times the speed setpoint slow rate. The speed setpoint slow rate, fast rate delay, and fast rate can all be adjusted in the Service mode.

The shortest length of time a setpoint will move for an accepted raise or lower command is 40 milliseconds (120 milliseconds for a Modbus command). If the speed setpoint slow rate is programmed for 10 rpm/sec, the smallest increment it will move is 0.4 rpm (1.2 rpm for Modbus).

The speed setpoint may be set to a specific level, by directly entering a setpoint value through the 505 keypad or Modbus communications. To "enter" a specific setpoint from the 505 keypad, press the SPEED key to view the speed control screen, press the ENTER key, enter the setpoint level desired, then press the ENTER key again. If a valid number was entered, the setting will be accepted and the Speed setpoint will ramp to the "entered" setpoint level. If an invalid number is "entered" the setting will not be accepted and the 505's screen will momentarily display a value out-of-range message. When a valid setpoint value is entered, the setpoint will ramp at the speed setpoint slow rate to the newly entered setpoint value. This 'Entered' rate is tunable through the Service mode.

When using the ENTER key from the front panel keypad, the 505 checks the validity of the new entered setpoint. The speed setpoint must be below the maximum governor setting and above the idle setting and not within a critical speed avoidance band. Once the speed setpoint is above the minimum governor setting, the setpoint cannot be lowered below minimum governor. Also, if the unit is driving a generator and the unit is on-line, the speed setpoint cannot be set below the minimum load setting. The minimum load setting is defaulted to 5 rpm above the isochronous speed setpoint (changeable in the Service Mode).

The speed setpoint can also be directly entered from either of the Modbus links, however, the allowed range is between the minimum governor and the maximum governor speed settings. The allowed setpoint range is limited to between the minimum load and the maximum governor settings if the unit is driving a generator and the unit is on-line.

When the 505 is configured for a generator application, a special speed setpoint rate (Sync Window Rate) is used to increase setpoint resolution around synchronous speed. This allows for tighter setpoint control to accommodate synchronizing manually or by an automatic synchronizer which interfaces to the 505 discretely. This Sync Window Rate is defaulted to two rpm/sec and is only used when the generator breaker is open and the speed setpoint is within 10 rpm of rated speed. Both the synchronizing rate and the synchronizing window are tunable in the Service mode.

When configured for generator applications a Minimum Load setpoint is used by the 505 to reduce the chance of reverse powering a unit upon closing the generator breaker. With the utility tie breaker closed, when a generator breaker closed indication is received, the Speed setpoint is stepped to the Minimum Load setting. The Minimum Load setting is defaulted to 3% (changeable in the Service Mode). To disable the use of the Minimum Load Setpoint, configure the 'Use Min Load' setting (under the Service mode's 'BREAKER LOGIC' header) to 'No'.

See Chapter 6 for a list of all speed setpoint related Modbus parameters.

Frequency Arm/Disarm

The Frequency Arm/Disarm feature can be used only when loadsharing is not being performed, to allow multiple units to operate on the same isolated bus. With this feature, one unit on a multiple unit isolated bus controls frequency and the other units operate in a unit-load mode. The unit controlling frequency is referred to as the "Swing Machine" because its load will swing (vary) depending on the load of the plant. Caution should be taken with this configuration to not overload or reverse power the "Swing Machine".

This feature, when programmed, allows an operator to Arm or Disarm a unit's Frequency control mode while it is in operation. When Armed, a unit will switch to Frequency control if the plant-to-utility tie breaker opens. When Disarmed, a unit will stay in a unit-load control mode when the plant-to-utility tie breaker opens.

To use this feature, the program's 'Use Freq Arm/Disarm' setting must be set to 'Yes', the Sync/Load Sharing mode cannot be programmed, and a discrete command must be programmed. The Frequency Arm/Disarm mode can be selected from a programmed contact input, Function key, or Modbus command. When the programmed contact input is closed the unit's Frequency control mode is Armed. When the programmed contact input is open the unit's Frequency control mode is Disarmed.

Depending on a unit's size, health, and running status, an operator may select which unit is designated as the plant Frequency control unit if or when the plant-to-utility tie breaker opens. Frequency control can be Armed at any time, but it will only go into control when the generator breaker is closed and the utility tie breaker is open.



CAUTION

Only one unit at a time should have its Frequency control mode Armed. If multiple units try to control plant frequency at the same time they may fight and cause system instability, with the potential of damage to the equipment due to overloading or reverse powering a machine.

If the 'Use Freq Arm/Disarm' setting is set to 'No', Frequency control is always Armed and the unit will go into Frequency control when the utility tie contact is open. If the program's 'Use Freq Arm/Disarm' setting is set to 'Yes' then Frequency control must first be armed before the unit will switch into Frequency control when the utility tie contact is open.

Speed Control Dual Dynamics

The Speed PID has a two sets of dynamics; off-line and on-line. When a system needs variable response times, due to changing system conditions, these dynamic variables allow the Speed PID to be tuned for optimal response.

When the 505 is configured for a generator application, the utility tie and generator breakers determine which set of dynamics is used by the Speed PID. The speed PID's off-line dynamics are selected when either the utility tie or generator breakers are open. The Speed PID's on-line dynamics are selected if both breakers are closed (see Table 3-1).

When not configured for a generator application, the 505 uses the programmed 'Min Governor Speed Setpoint' setting to determine which set of dynamic values are used by the Speed PID. The Speed PID's off-line dynamics are selected when turbine speed is below the 'Min Governor Speed Setpoint' setting. The Speed PID's on-line dynamics are selected when turbine speed is above the 'Min Governor Speed Setpoint' setting. (see Table 3-1).

When not configured for a generator application, the 505 will transfer from off-line to on-line dynamics once minimum governor speed is reached.

Optionally a contact input may be programmed to perform a "Select On-Line Dynamics" function. If this contact is programmed the utility tie and generator breaker positions (gen applications), and the minimum speed setting status (non-gen applications) do not effect dynamics selection. When the programmed contact input is open, off-line dynamics are selected and used by the Speed PID. When the programmed contact input is closed, on-line dynamics are selected and used by the Speed PID.

A relay can be programmed to indicate that the On-Line Dynamics are selected and used by the Speed PID.

Dynamic values are defined in the program mode and tunable at any time. Refer to the PID Dynamic Adjustments section in this manual.

CONFIGURATION	ON-LINE DYNAMICS SELECTED	OFF-LINE DYNAMICS SELECTED
GEN SET	BOTH BREAKERS CLOSED	EITHER BREAKER OPEN
NOT A GEN SET	SPD > MIN GOV SETTING	SPD < MIN GOV SETTING
*CONTACT INPUT	CLOSED	OPEN

*The contact input option has priority, when programmed.

Table 3-1. On-Line/Off-Line Dynamics Selection

Remote Speed Setpoint

The Speed setpoint can be positioned remotely through an analog signal by programming the Remote Speed Setpoint analog input. This allows the Speed setpoint to be set remotely by a process control or distributed plant control system.

The Remote Speed Setpoint (RSS) range is determined by the programmed Analog input's 4 mA and 20 mA settings. The Remote Speed Setpoint range is tunable in the Service mode (under REMOTE SPEED SETTINGS), but cannot control outside of the min governor and max governor speed setpoint values.

Since RSS is a secondary speed setting function, the Speed PID must be in control of the 505's LSS bus to allow the RSS to position the actuator. When configured as a generator application, the RSS will not take control unless both breakers are closed and the speed PID is in control. When not configured as a generator application, turbine speed must reach min governor before the RSS can take control. The Cascade and Auxiliary (if configured to be enabled/disabled) controls are automatically disabled if RSS is enabled.

The Remote Speed Setpoint may be enabled or disabled from the 505 keypad, external contact or Modbus. The last command given from any of these three sources dictates the enabled/disabled state. It does not matter whether the last command was given from the keypad or other devices.

A contact input can be programmed to perform as an external "Remote Speed Setpoint Enable" function. When this programmed contact is open the RSS is disabled, and when it is closed the RSS is enabled. The contact can be either open or closed when trip condition is cleared. If the contact is open it must be closed to enable the RSS. If the contact is closed it must be opened and re-closed to enable the RSS function.

If the milliamp signal to the Remote Speed setpoint input is out of range (below 2 mA or above 22 mA) an alarm will occur and the Remote Speed setpoint will be inhibited until the input signal is corrected and the alarm is cleared.

Remote Speed Setpoint Status Messages

The Remote Speed Setpoint may be in one of the following states (505 front panel screen messages):

- Disabled—The remote setpoint function is not enabled and will have no effect on the speed setpoint.
- Enabled—The remote setpoint has been enabled.
- Active—The remote setpoint is in control of the Speed setpoint but the speed PID is not in control of the actuator output.
- In Control—The remote setpoint is in control of the Speed setpoint and the speed PID is in control of the actuator output.
- Inhibited—RSS cannot be enabled. The input signal has failed, a controlled stop is selected, the unit is shut down, or RSS is not programmed.

When enabled, the Remote Speed setpoint may not match the Speed setpoint. In this case, the Speed setpoint will ramp to the Remote Speed setpoint at the programmed 'Speed Setpoint Slow Rate' setting (as defaulted in the Service mode). Once in control, the maximum rate that the Speed setpoint will ramp, for a RSS change, is at the programmed 'Remote Speed Setpoint Max Rate' setting. If the 'Remote Speed Setpoint Max Rate' were set at 10 rpm/sec and the Remote Speed setpoint analog input instantly moved from 3600 rpm to 3700 rpm, the Speed setpoint will move to 3700 rpm at 10 rpm/sec.

Refer to Volume 2 of this manual for information on related Service mode tunables.

All pertinent Remote Speed Setpoint parameters are available through the Modbus links, refer to Chapter 6 for a complete listing of Modbus parameters.

Synchronization

Automatic generator synchronization can be performed through a Woodward Digital Synchronizer & Load Control (DSLCL). The DSLCL connects to a 505 analog input to bias the 505's speed setpoint directly to vary generator speed, frequency and phase. Optionally the DSLCL can interface with the unit voltage regulator to match system voltage across a generator breaker.

When the 505 is configured for a Generator application, a special speed setpoint rate (Sync Window Rate) is used to increase setpoint resolution around synchronous speed. This allows for tighter setpoint control to accommodate synchronizing manually or by an automatic synchronizer which interfaces to the 505 discretely. This Sync rate is defaulted to two rpm/sec and is only adjustable through the 505's Service mode. This rate is only used when the generator breaker is open the speed setpoint is within +10 rpm of rated speed (also tunable through the Service mode).

The DSLCL can be used as a synchronizer only or as a synchronizer and load control. When the DSLCL is used as a synchronizer only, the 505 must be configured to accept the DSLCL's analog Speed Bias signal and have this input enabled. A 'Sync Enable' contact input or function key (F3 or F4) can be programmed to enable the 505's synchronizing input when synchronization is desired. The Sync Enable command becomes disabled when the generator breaker closes, however, it may re-enabled again to allow the DSLCL to perform tie breaker synchronizations. To re-enable this input the 'Sync Enable' contact must be opened and re-closed. Typically a double pole single throw (DPST) switch is used on a site's synchronizer control panel to select automatic synchronizing by enabling both the DSLCL sync mode and 505 analog input at the same time.

To configure the 505 to utilize a DSLCL for generator synchronization only, program the 'Synchronizing input' function to the 'ANALOG INPUT #6' setting and program the 'Sync Enable' function to a 'CONTACT INPUT X' setting. Analog Input #6 is isolated and is the only input directly compatible with the DSLCL's output signal. The 'Synchronizing input' function has preset range and gain settings that are tunable only in the Service mode. Thus the 4 mA and 20 mA Program Mode settings for the Synchronizing input are irrelevant and are not used by the function's operation. See Volume #2 of this manual or Woodward manual 02007 for more information on applying the DSLCL.

When programming a Function Key (F3 or F4), instead of a contact input, to enable the 505's analog Synchronizing input, a 505 relay output can also be programmed to select a DSLCL's synchronizing mode. To configure the 505 for this functionality, program the 'Sync Enable' function to a 'FX KEY PERFORMS' setting, and the 'Sync Enabled' function to a 'RELAY X ENERGIZES ON' setting.

When the 505 is programmed to use the DSLC for Synchronization, the RMT key can also be used to access and enable the Synchronizing function and monitor all synchronization mode messages. See Chapter 5 for information on how to enable this function through the RMT key. By pressing the RMT key and scrolling up or down through the RMT screens, the following synchronizing mode messages can be viewed:

- Disabled—The Synchronizing Input is disabled and will have no effect on the Speed setpoint.
- Enabled—The Synchronizing Input has been enabled.
- In Control—The Synchronizing Input is biasing the Speed setpoint.
- Inhibited—The Synchronizing Input is inhibited and cannot be enabled. input signal is failed, both the utility tie and generator breakers are closed, the turbine is shut down, a controlled shutdown is being performed, or synchronizing control is not programmed.

Synchronizing/Loadsharing

A Woodward Digital Synchronizer & Load Control (DSLCL) is used with a 505 to allow automatic generator synchronization to a bus and the sharing of load with other units (using DSLCLs on the same bus). The Woodward DSLCL is a microprocessor based generator load control designed for use on three-phase AC generators with Woodward speed controls and automatic voltage regulators.

A DSLCL with VAR/Power Factor control, allows all units with DSLCLs to reactive load share as well as real power load share. The DSLCL senses unit load through generator PTs & CTs and system load through the DSLCL LON network (a combination of all units on the network). The DSLCL uses a digital Echelon Network (LON) to communicate with other DSLCLs on the same bus.

When used as a synchronizer and load control, the DSLCL performs automatic synchronization and controls unit load based on an internal base-load setting, a system average load setting, a process loop's control setting, or a Master Synchronizer & Load Control's (MSLCL) demand setting.

After synchronization, unit load can be controlled by the DSLCL through the Sync/Load Share input or by the 505's internal speed/load setpoint. The Utility Tie Breaker Contact is used to select unit load control through the DSLCL or through the 505's internal load setpoint. When the 505's internal load control is selected (utility tie contact closed), the Speed PID setpoint is used to control unit load. Optionally the Cascade or Auxiliary control modes may be used to set unit load based on another system parameter.

The DSLCL interfaces to the 505 via its Speed Bias signal. To configure the 505 to utilize a DSLCL for generator synchronizing and load sharing, program the 'Sync/Load Share input' function to the 'Analog Input #6' setting and program the 'Sync/Ld Share Enable' function to a 'Contact Input #X' setting. Analog Input #6 is isolated, and the only input directly compatible with the DSLCL's output signal. The 'Sync/Ld Share input' function has preset range and gain settings that are tunable only in the Service mode (see Volume 2). Thus the 4 mA and 20 mA Program Mode settings for the Synchronizing input are irrelevant and are not used by the function's operation.

A combination of the Utility Tie Breaker contact, Generator Breaker contact, and Sync/Ld Share Enable contact define the state of the 505's synchronizing and loadsharing operating modes (See Table 3-2).

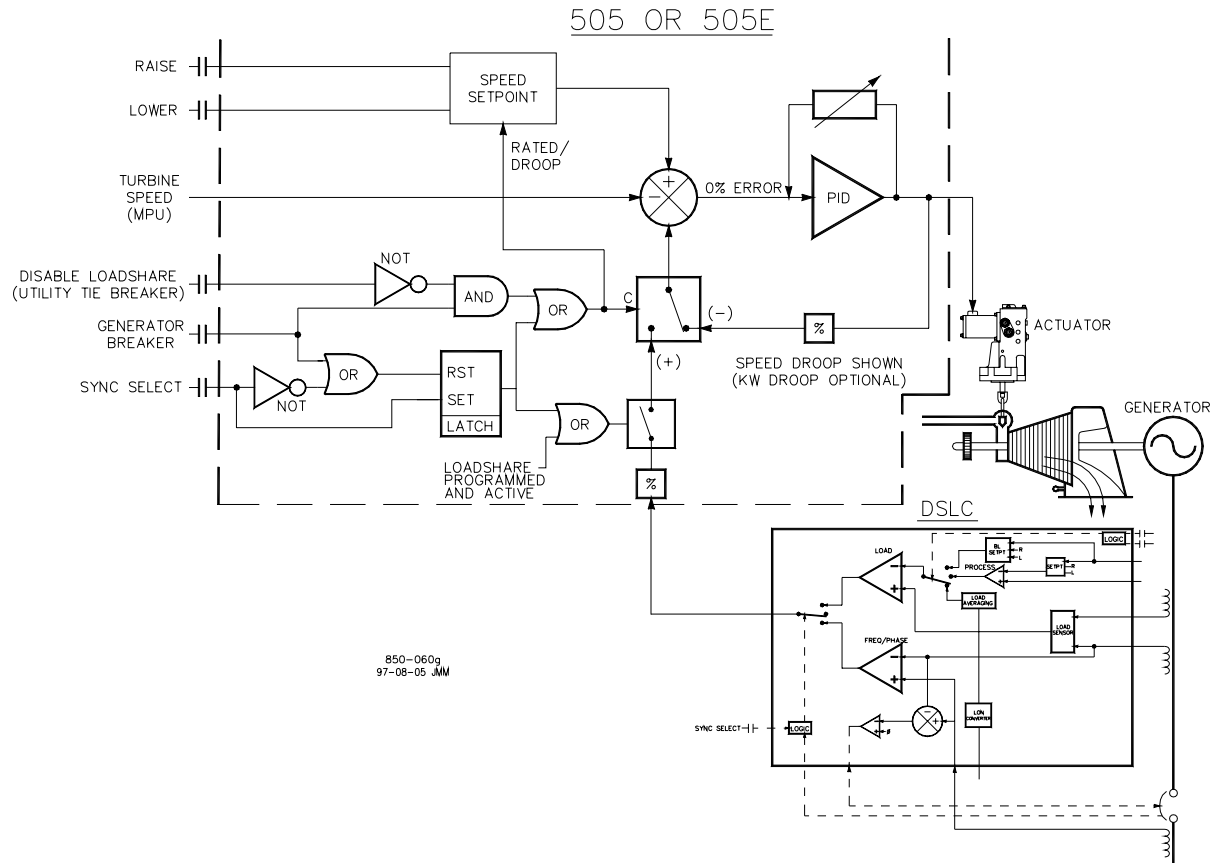

Figure 3-11. Loadsharing Logic

The Utility Tie breaker contact input is used to enable and disable Load Sharing when the generator breaker is closed. If the Utility Tie contact is open, loadsharing is enabled, and the 505's internal Speed PID droop, Cascade, and Auxiliary modes are disabled (as defaulted in Service mode). If the Utility Tie contact is closed loadsharing is disabled and the 505's Speed PID droop, Cascade, and Auxiliary modes are enabled, if used.

The Generator Breaker contact input is used in conjunction with the utility tie contact to activate loadsharing.

The 'Sync/Ld Share Enable' contact input option is used to enable the Sync/Load Share analog input before the generator breaker is closed. Optionally a Function Key (F3 or F4) can be programmed to enable the 505's Sync/Load Share analog input instead of an external contact. This discrete enable/disable function is ignored after the generator breaker is closed, and must be reselected after the generator breaker opens. Typically a double pole single throw (DPST) switch is used on a site's synchronizer control panel to select automatic synchronizing by enabling both the DS/LC sync mode and 505 analog input at the same time.

Tie Breaker Contact Status	Gen Breaker Contact Status	Sync/Ld Share Enable Contact	Speed Control Mode	Cascade or Auxiliary (if used)
closed	open	open	Speed, Off-Line Dynamics	not active
closed	closed	XXXX	Unit Load Control, On-Line Dynamics	active
open	open	open	Speed, Off-Line Dynamics	not active
open	open	closed	Synchronizing Off-Line Dynamics	not active
open	closed	XXXX	Load Sharing, Off- Line dynamics	not active

Table 3-2. Load Sharing Logic

When programming a Function Key (F3 or F4) instead of a contact input to enable the 505's analog Sync/Load Share input, a 505 relay output, can be also be programmed to select a DSLC's synchronizing mode. To configure the 505 for this functionality, program the 'Sync/Ld Share Enable' function to a 'FX KEY PERFORMS' setting, and the 'Sync/Ld Share Enabled' function to a 'RELAY X ENERGIZES ON' setting.

When the 505 is programmed to use the DSLC for Synchronization and Load Sharing, the RMT key can be used to access and enable the Sync/Load Share function and monitor all function mode messages. See Chapter 5 for information on how to enable this function through the RMT key. By pressing the RMT key and scrolling up or down through the RMT screens, the following Sync/Load Share mode messages can be viewed:

- Disabled—The Sync/Load Share Input is disabled and will have no effect on the Speed setpoint.
- Enabled—The Sync/Load Share Input has been enabled.
- In Control—The Sync/Load Share Input is biasing the Speed setpoint.
- Inhibited—The Sync/Load Share Input cannot be enabled; the input signal is failed, the turbine is shut down, a controlled shutdown is being performed, or the sync/load share feature is not programmed.
- All pertinent synchronizing and loadsharing parameters are available through the Modbus links. See Chapter 6 for a complete listing of Modbus parameters.

Cascade Control

The Cascade control can be configured to control any system process, related to or affected by turbine speed or load. Typically this controller is configured and used as a turbine inlet or exhaust pressure controller.

Cascade control is a PID controller that is cascaded with the Speed PID. The Cascade PID compares a 4–20 mA process signal with an internal setpoint to directly position the speed setpoint, thus changing turbine speed or load until the process signal and setpoint match. By Cascading two PIDs in this fashion, a bumpless transfer between the two controlling parameters can be performed.

When enabled, the Cascade PID can move the speed setpoint at a variable rate up to the 'Max Speed Setpoint Rate' setting (programmed under the CASCADE CONTROL header).

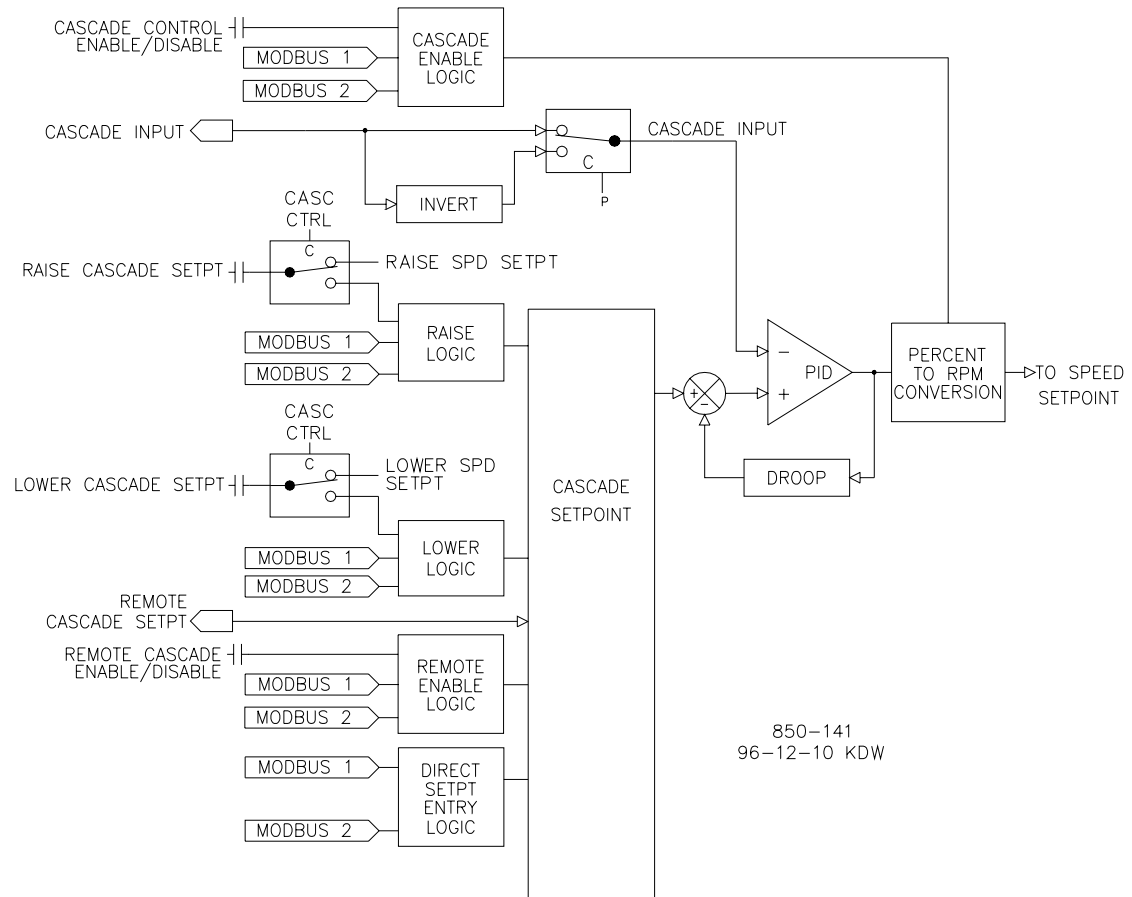

Figure 3-12. Cascade Functional Diagram

Since Cascade is a secondary speed setting function, the Speed PID must be in control of the 505's LSS bus in order for Cascade to take control. When the 505 is configured for a generator application, both the utility tie and generator breakers must be closed, before the Cascade PID can begin controlling a process.

Cascade control may be enabled and disabled from the 505 keypad, a contact input, or Modbus communications. The last command given from any of these three sources dictates the Cascade PID's control state.

If a contact input is programmed to function as a Cascade Enable contact, when the contact is open Cascade control is disabled, and when it is closed Cascade control is enabled. This contact can either be open or closed when a trip condition is cleared. If the contact is open it must be closed to enable Cascade control. If the contact is closed it must be opened and re-closed to enable Cascade control.

Cascade Control Status Messages

- Cascade is Disabled—Cascade control is not enabled and will have no effect.
- Cascade is Enabled—Cascade has been enabled but is not active or in control. Permissives have not been met (speed < min gov, generator or tie breaker open).
- Casc Active/Not Spd Ctl—Cascade has been enabled but the Speed PID is not in control of the LSS bus (either aux or valve limiter is in control).
- Cascade is In Control—Cascade is in control of the LSS bus.
- Casc Active w/Rmt Setpt—Cascade has been enabled and the Remote Cascade setpoint is in control of the setpoint but the Speed PID is not in control of the LSS bus.
- Casc Control w/Rmt Setpt—Cascade is in control of the LSS bus (via the Speed PID) and the Remote Cascade Setpoint is positioning the Cascade setpoint.
- Cascade is Inhibited—Cascade cannot be enabled; the Cascade input signal has failed, a controlled stop is selected, the unit is shut down, or cascade control is not programmed.

Cascade control is automatically disabled on a shutdown condition, and must be re-enabled after a successful system startup. Cascade control is disabled if Remote Speed Setpoint is used and enabled. Should another parameter on the LSS bus take control of governor valve position from the Speed PID, Cascade control will stay active, and begin controlling again when the Speed PID is the lowest parameter on the LSS bus again.

All pertinent cascade control parameters are available through the Modbus links, refer to Chapter 6 for a complete listing of Modbus parameters.

Cascade Dynamics

The Cascade PID control uses its own set of dynamic settings. These values are programmable and may be tuned at any time. Refer to the PID Dynamic Adjustments section in this manual.

Cascade Setpoint

The Cascade setpoint can be adjusted from the 505 keypad, external contacts, Modbus commands, or through a 4–20 mA analog input. A specific setting can also be directly entered from the 505 keypad or through Modbus commands.

The Cascade setpoint range must be defined in the program mode. Program settings 'Min Cascade Setpoint' and 'Max Cascade Setpoint' define the range of the Cascade setpoint and control.



NOTE

Cascade setpoint raise/lower contact inputs act as speed setpoint raise/lower contacts when Cascade is not active or in control. This allows a single set of contacts (one SPDT switch) to control the Speed setpoint when the generator breaker is open, the load setpoint when paralleled to a utility, and the Cascade setpoint when enabled. Alternatively, a second set of contacts (speed raise and lower) could be used to independently control the speed and load setpoints.

When a raise or lower Cascade Setpoint command is issued, the setpoint moves at the programmed 'Casc Setpt Rate' setting. If a Cascade raise or lower command is selected for longer than three seconds, the Cascade setpoint will move at the fast rate which is three times the cascade setpoint rate. The Cascade setpoint rate, fast rate delay, and fast rate can all be adjusted in the Service mode.

The shortest length of time a setpoint will move for an accepted raise or lower command is 40 milliseconds (120 milliseconds for a Modbus command). If the Cascade setpoint slow rate is programmed for 10 psi/sec, the smallest increment it will move is 0.4 psi (1.2 psi for Modbus).

A specific setpoint may also be directly entered from the 505 keypad or through Modbus communications. When this is performed, the setpoint will ramp at the 'Casc Setpt Rate' (as defaulted in Service mode). To "enter" a specific setpoint from the 505 keypad, press the CAS key to view the Cascade control screen, press the ENTER key, enter the setpoint level desired, then press the ENTER key again. If a valid number was entered, equal-to or between the min and max setpoint settings, the setting will be accepted and the Cascade setpoint will ramp to the "entered" setpoint level. If an invalid number is "entered", the setting will not be accepted and the 505's screen will momentarily display a value out-of-range message.

When a valid setpoint value is entered, the setpoint will ramp at the Cascade Setpoint Rate to the newly entered setpoint value. This 'Entered' rate is tunable through the Service mode.

Refer to Volume 2 of this manual for information on which programmed settings are tunable through the 505's Service mode. Service mode values can be tuned/adjusted while the 505 is shutdown or in the RUN mode.

Cascade Setpoint Tracking

To allow a bumpless transfer from turbine Speed/load control to Cascade control, the Cascade PID can be programmed to track its controlling process input when disabled. When this tracking feature is programmed, the Cascade PID will be satisfied when enabled, and no turbine speed or load correction will be performed. After the Cascade control is enabled, its setpoint can be moved, as required, to another setting.

Cascade Setpoint with No Tracking

If the Cascade control is programmed not to use the setpoint tracking feature the setpoint will remain at its last setting (running or shutdown). When the 505 is powered-up the setpoint is reset to the 'Setpt Initial Value'. With this configuration, when Cascade control is enabled, and its sensed process signal does not match setpoint, the Cascade control will ramp turbine speed/load up or down to match the two signals, at a controlled "not-matched" rate (defaulted to the 'Speed Setpoint Slow Rate' setting, and tunable through the Service mode).

If Cascade is the controlling parameter and one of the permissives is lost or Cascade is disabled, the speed setpoint will remain at its last setting until another parameter adjusts it.

Cascade Droop

When sharing control of a parameter with another external controller, the Cascade PID can also receive a programmable DROOP feedback signal for control loop stability. This feedback signal is a percentage of the Cascade PID's output. By including this second parameter into the control loop, the Cascade PID becomes satisfied, and does not fight with the other external controller over the shared parameter. If Cascade droop is used, the Cascade input signal will not match the Cascade setpoint when in control. The difference will depend on the amount (%) of droop programmed and the output of the Cascade PID. The Droop value fed back to the Cascade PID is equal to the following defaulted settings:

$$\text{PID OUTPUT \%} \times \text{'CASCADE DROOP \%'} \times \text{'MAX CASC SETPOINT'} \times 0.0001$$

Where the 'CASCADE DROOP %' and 'MAX CASC SETPOINT' values are set in the Program Mode and the 'PID output %' is determined by the Cascade demand.

$$\text{Example: } 25\% \times 5\% \times 600 \text{ psi} \times 0.0001 = 7.5 \text{ psi}$$

Refer to Volume 2 of this manual for information on related Service mode tunables.

Invert Cascade

Depending on the control action required, the Cascade input signal can be inverted. If a decrease in inlet governor valve position is required to increase the Cascade process signal, program the 'INVERT CASCADE INPUT' setting to 'YES'. An example of this required control action would be when the Cascade PID is configured to control turbine inlet steam pressure. To increase turbine inlet steam pressure, the inlet control valve position must be decreased.

Remote Cascade Setpoint

The Cascade setpoint can be positioned through an analog signal. Optionally, one of the 505's six analog inputs can be programmed to position the Cascade PID setpoint. This allows the Cascade setpoint to be positioned remotely by a process control or distributed plant control system.

The Remote Cascade Setpoint (RCS) range is determined by the programmed Analog input's 4 mA and 20 mA settings. The Remote Cascade Setpoint range is tunable in the Service mode, but cannot be set outside of the min and max Cascade Setpoint settings.

The Remote Cascade Setpoint input may be enabled from the 505 keypad, contact input, or Modbus communications. The last command given from any of these three sources dictates enable/disable.

If the milliamp signal to the Remote Cascade setpoint input is out of range (below 2 mA or above 22 mA) an alarm will occur and the Remote Cascade setpoint will be inhibited until the input signal is corrected and the alarm is cleared. Depending on configuration and system conditions, the Remote Cascade Setpoint may be in one of the following states (505 front panel screen messages):

- Disabled—The Remote Setpoint function is not enabled and will have no effect on the Cascade setpoint.
- Enabled—The Remote Setpoint has been enabled but cascade control is not active. The breakers are not closed, speed < min gov, or cascade has not taken control.
- Active—The Remote Setpoint has been enabled but Cascade is not in control. Cascade has been enabled and the Remote Cascade setpoint is in control of the setpoint but the Speed PID is not in control of the LSS bus.
- In Control—Cascade is in control of the LSS bus (via the Speed PID) and the Remote Cascade Setpoint is positioning the Cascade setpoint.
- Inhibited—Remote Setpoint cannot be enabled; input signal is failed, Cascade input signal is failed, a controlled stop is selected, the unit is shut down, or the remote cascade control is not programmed.

When enabled, the Remote Cascade setpoint may not match the Cascade setpoint. In this case, the Cascade setpoint will ramp to the Remote Cascade setpoint at the programmed 'Casc Setpt Rate' setting (as defaulted in the Service mode). Once in control, the fastest the Remote Cascade setpoint will adjust the Cascade setpoint is at the programmed 'Rmt Cascade Max Rate' setting. If the 'Rmt Cascade Max Rate' was set at 10 and the Remote Cascade setpoint analog input instantly moved from 0 units to 1000 units, the Remote Cascade setpoint will move to 1000 units at 10 units/sec).

Remote Cascade Enable Logic

There are three different options for enabling Remote Cascade Setpoint and Cascade control as follows:

- One Remote Enable contact input or function key command
- Both enable commands programmed; Remote Casc Enable and Cascade Enable
- No enable commands programmed

When only one Remote Enable command is programmed (either F-key or contact input), selecting 'Enable' will enable both Cascade control and Remote Cascade control. This configuration allows both functions to be enabled with one command if this is the normal operation mode. If 'Disable' is selected, both control modes are disabled.

A contact input can be programmed to enable and disable the Remote Cascade Setpoint (RCS) input/function. When this contact is open the RCS is disabled, and when it is closed the RCS is enabled. The contact can be either open or closed when a trip condition is cleared. If the contact is open it must be closed to enable the RCS input. If the contact is closed it must be opened and re-closed to enable the RCS input.

When both Remote Cascade Enable and Cascade Control Enable commands are programmed, each function is enabled by its respective command selection. If Remote Cascade Enable is selected, only the Remote Cascade Setpoint will be enabled. If Cascade Control Enable is selected, only Cascade control will be enabled. If Remote Cascade Disable is selected, only the Remote Cascade Setpoint will be disabled. If Cascade Control Disable is selected, both Remote Cascade control and Cascade control will be disabled. However, if before the Cascade PID was 'In-control', a Cascade disabled command is given, only Cascade control will be disabled.

If no external contact input or function keys are programmed for the 'Enable' commands, Cascade Control and Remote Cascade Control must be enabled from either the front panel keypad or from Modbus. Since the front panel and Modbus provide both Remote Cascade Enable and Cascade Control Enable commands, they will operate in the same manner as 'both enables programmed'.

Refer to Volume 2 of this manual for information on related Service mode tunables. All pertinent Remote Cascade control parameters are available through the Modbus links. See Chapter 6 for a complete listing of Modbus parameters.

Auxiliary Control

The Auxiliary PID controller can be used to limit or control generator power, plant import/export power, turbine inlet pressure, turbine exhaust pressure, pump/compressor discharge pressure, or any other auxiliary parameters, directly related to turbine speed/load. The Auxiliary input is a 4 to 20 mA current signal. The PID control amplifier compares this input signal with the Auxiliary setpoint to produce a control output to the digital LSS (low-signal select) bus. The LSS bus sends the lowest signal to the actuator driver circuitry.

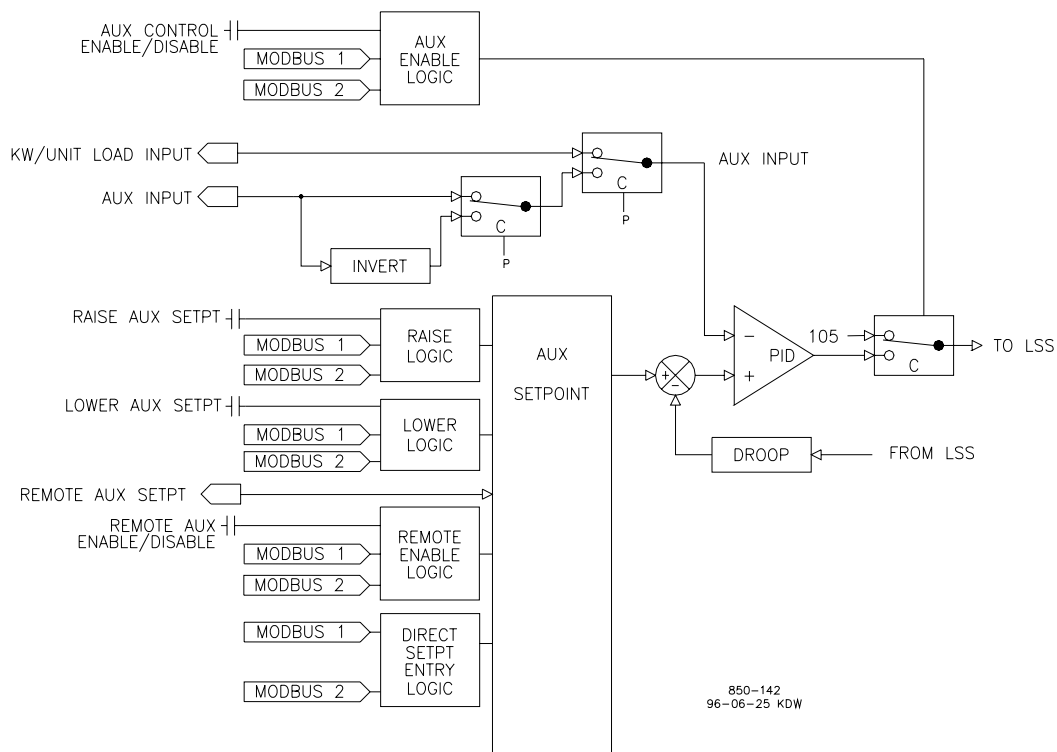

Figure 3-13. Aux Control Overview

Auxiliary as a Limiter (not using Enable/Disable)

When configured as a limiter, the Auxiliary control is low signal selected (LSS) with the Speed PID, allowing it to limit turbine speed/load based on any auxiliary parameter which is directly related. To configure the Auxiliary controller to function as a limiter, program the 'Use Aux Enable' setting to 'NO'.

When Auxiliary is configured to act as a limiter the Auxiliary PID will 'limit' the LSS bus when the input reaches the setpoint. The Aux setpoint initializes to the programmed 'Setpt Initial Value' setting on a power-up-reset. This setpoint may be adjusted at any time and will remain at a setting (running or shutdown), provided a power-up-reset did not occur.

Depending on configuration and system conditions, the Auxiliary Limiter may be in one of the following states (505 front panel screen messages):

- Auxiliary is Enabled—Auxiliary has been enabled but the generator and utility tie breaker permissives have not been met (generator applications only).
- Aux Active/Not Lmtng—Auxiliary is configured as a limiter but is not limiting the LSS bus.
- Aux Active w/Rmt Setpt—Auxiliary is not in control of the LSS bus and the remote Auxiliary input is in command of the setpoint.
- Aux Control w/Rmt Setpt—Auxiliary is in limiting the LSS bus and the remote Auxiliary analog input is in command of the setpoint.
- Auxiliary is Inhibited—Auxiliary cannot be enabled. The input signal has failed.

For generator applications, Auxiliary control can be configured to be disabled when the generator and/or utility tie breakers are open. Program settings 'Genbkr Open Aux Dsbl' and 'Tiebkr Open Aux Dsbl' may be configured to deactivate Auxiliary PID limiting, depending on system breaker positions. When both settings are programmed 'NO', the Auxiliary limiter will always stay 'active'. If either setting is programmed 'YES', the Auxiliary limiter will be active only when the tie breaker or generator breaker respectively, is closed.

If the unit is not configured for a generator application, the utility tie and generator breaker inputs do not affect Auxiliary limiter status, and the Limiter will be active at all times.

Auxiliary as a Controller (using Enable/Disable)

When configured as a controller, the Auxiliary PID may enabled and disabled on command. With this configuration, when Auxiliary control is enabled it instantly takes full control of the LSS bus, and the Speed PID is switched to a tracking mode. When Auxiliary control is disabled the Speed PID instantly takes full control of the LSS bus. To allow a bumpless transfer between modes, when the Auxiliary PID is enabled, the Speed PID tracks a few % above the Auxiliary PID's LSS bus signal. When the Auxiliary PID is disabled, its setpoint tracks the Auxiliary PID's process signal.

To configure the Auxiliary controller to function as a controller, program the 'Use Aux Enable' setting to 'YES'.

The Speed PID will only track the Auxiliary PID LSS bus signal up to 100% speed/load. Thus if turbine speed/load reaches 100%, the Speed PID will protect the unit by limiting unit speed/load to less than or equal to 100%.

Depending on the configuration and system conditions, the Auxiliary PID may be in one of the following states (505 front panel screen messages):

- Auxiliary is Disabled—Auxiliary is disabled and will have no effect on the LSS bus.
- Auxiliary is Enabled—Auxiliary has been enabled but the generator and utility tie breaker permissives have not been met (generator applications only).
- Aux Active/Not in Ctrl—Auxiliary has been enabled, permissives met, but is not in control of the LSS bus.
- Aux Active w/Rmt Setpt—Auxiliary has been enabled but is not in control of the LSS bus and the remote Auxiliary input is controlling the setpoint.
- Auxiliary in Control—Auxiliary is in control of the LSS bus.
- Aux Control w/Rmt Setpt—Auxiliary is in control of the LSS bus and the remote Auxiliary analog input is in control of the setpoint.
- Auxiliary is Inhibited—Auxiliary cannot be enabled; input signal is failed, 505 is in Frequency Control, controlled shutdown is selected, unit is shut down or Auxiliary control is not programmed.

For generator applications, Auxiliary control can be configured to be disabled when the generator and/or utility tie breakers are open. Program settings 'TIEBKR OPEN AUX DSBL' and 'GENBKR OPEN AUX DSBL' may be configured to deactivate Auxiliary control depending on system breaker positions. When both settings are programmed 'NO', the Auxiliary control will always stay 'active'.

If the unit is not configured for a generator application, the utility tie and generator breaker inputs do not affect Auxiliary control status, and the controller will be active at all times (capable of being enabled).

Auxiliary control may be enabled from the 505 keypad, remote contacts, or Modbus communications. The last command given from any of these three sources dictates which state the Auxiliary control is in. If an external Auxiliary Enable contact is programmed, disable is selected when the contact is open and enable is selected when it is closed. The contact can be either open or closed when a trip condition is cleared. If the contact is open it must be closed to enable. If the contact is closed it must be opened and re-closed to enable.

When configured as enable/disable controller, the Auxiliary control will automatically be disabled upon a shutdown condition. Auxiliary control will be disabled and inhibited when the 505 is in frequency control. If the Auxiliary milliamp input signal is out of range (below 2 mA or above 22 mA) an alarm will occur and Auxiliary control will be inhibited until the input signal is corrected and the alarm is cleared. Optionally the unit can be programmed to issue a shutdown on a loss of the Auxiliary input signal.

Auxiliary Dynamics

The Auxiliary PID control uses its own set of dynamic settings. These values are programmable and may be tuned at any time. Refer to the PID Dynamic Adjustments section in this manual.

Generator Load Limiter/Control

On generator applications, the Auxiliary PID may be programmed to use the 'KW/UNIT LOAD' input signal instead of the Auxiliary input signal for limiting or control. This is the same input signal (KW/Unit Load input) used by the Speed PID for KW droop. This configuration allows the Auxiliary PID to limit or control generator power. Program the 'USE KW/UNIT LOAD INPUT' to 'YES' if this configuration is desired.

Auxiliary Droop

When sharing control of a parameter with another external controller, the Auxiliary control amplifier can also receive a programmable DROOP feedback signal for control loop stability. This feedback signal is a percentage of the LSS bus (control valve position). By including this second parameter into the control loop, the Auxiliary PID becomes satisfied, and does not fight with the other external controller over the shared parameter. The Droop % fed back to the Auxiliary PID is equal to the following defaulted settings:

$$\text{LSS BUS OUTPUT \%} \times \text{'AUXILIARY DROOP \%'} \times \text{'MAX AUX SETPOINT'} \times 0.0001$$

$$\text{Example: } 25\% \times 5\% \times 600 \text{ psi} \times 0.0001 = 7.5 \text{ psi}$$

Where the 'AUXILIARY DROOP %' and 'MAX AUX SETPOINT' values are set in the Program Mode and the 'LSS bus output %' is determined by the Auxiliary demand.

Invert Auxiliary Input

Depending on the control action required, the Auxiliary PID's input signal can be inverted. If a decrease in inlet control valve position is required to increase the Auxiliary process signal, program the 'INVERT AUX INPUT' setting to 'YES'. An example of this control action would be when the Auxiliary PID is configured to control turbine inlet steam pressure. To increase turbine inlet steam pressure, inlet control valve position must be decreased.

Auxiliary Setpoint

The Auxiliary setpoint can be adjusted from the 505 keypad, external contacts, Modbus commands, or through a 4–20 mA analog input. A specific setting can also be directly entered from the 505 keypad or through Modbus commands.

The Auxiliary setpoint range must be defined in the program mode. Program settings 'Min Aux Setpoint' and 'Max Aux Setpoint' define the range of the Auxiliary setpoint and control.

When a raise or lower Auxiliary Setpoint command is issued, the setpoint moves at the programmed 'Aux Setpt Rate' setting. If a Auxiliary raise or lower command is selected for longer than three seconds, the Auxiliary setpoint will move at three times the fast rate which is three times the Auxiliary setpoint rate. The Auxiliary setpoint rate, fast rate delay, and fast rate can all be adjusted in the Service mode.

The shortest length of time a setpoint will move for an accepted raise or lower command is 40 milliseconds (120 milliseconds for a Modbus command). If the Cascade setpoint slow rate is programmed for 10 psi/sec, the smallest increment it will move is 0.4 psi (1.2 psi for Modbus).

A specific setpoint may also be directly entered from the 505 keypad or through Modbus communications. When this is performed, the setpoint will ramp at the 'Aux Setpt Rate' (as defaulted in Service mode). To "enter" a specific setpoint from the 505 keypad, press the AUX key to view the Auxiliary control screen, press the ENTER key, enter the setpoint level desired, then press the ENTER key again. If a valid number was entered, equal-to or between the min and max setpoint settings, the setting will be accepted and the Auxiliary setpoint will ramp to the "entered" setpoint level. If an invalid number is "entered", the setting will not be accepted and the 505's screen will momentarily display a value out-of-range message.

When a valid setpoint value is entered, the setpoint will ramp at the Auxiliary Setpoint Rate to the newly entered setpoint value. This 'Entered' rate is tunable through the Service mode.

Refer to Volume 2 of this manual for further information on Service mode and on-line tunables. All pertinent auxiliary control parameters are available through the Modbus links. See Chapter 6 for a complete listing of Modbus parameters.

Remote Auxiliary Setpoint

The Auxiliary setpoint can be positioned through an analog signal. Optionally, one of the 505's six analog inputs can be programmed to position the Auxiliary PID setpoint. This allows the Auxiliary setpoint to be positioned remotely by a process control or distributed plant control system.

The Remote Auxiliary Setpoint (RAS) range is determined by the programmed Analog input's 4 mA and 20 mA settings. The Remote Auxiliary Setpoint range is tunable in the Service mode, but cannot be set outside of the min and max Auxiliary Setpoint settings.

When enabled, the Remote Auxiliary Setpoint may not match the Auxiliary setpoint. In this case, the Auxiliary setpoint will ramp to the Remote Auxiliary Setpoint at the programmed 'Aux Setpoint Rate' setting (as defaulted in the Service mode). Once in control, the fastest the Remote Auxiliary Setpoint will adjust the Auxiliary setpoint is at the programmed 'Rmt Aux Setpt Max Rate' setting. If the 'Rmt Aux Setpt Max Rate' were set at 10 and the Remote Auxiliary Setpoint analog input instantly moved from 0 units to 1000 units, the Auxiliary setpoint will move to 1000 units at 10 units/sec.

If the milliamp signal to the Remote Auxiliary Setpoint input is out of range (below 2 mA or above 22 mA) an alarm will occur and the Remote Auxiliary Setpoint will be inhibited until the input signal is corrected and the alarm is cleared. Depending on configuration and system conditions, the Remote Auxiliary Setpoint may be in one of the following states (505 front panel screen messages):

- Disabled—The Remote Setpoint function is disabled and will have no effect on the Aux setpoint.
- Enabled—The Remote Setpoint has been enabled, but permissives are not met.
- Active—The Remote Setpoint has been enabled, permissives are met, but Auxiliary PID is not in control of the LSS bus.

- In Control—The Remote Setpoint is in control of the Auxiliary setpoint, and the Auxiliary PID is in control of the LSS bus.
- Inhibited—Remote Setpoint cannot be enabled; Remote Setpoint input signal is failed, Auxiliary control is Inhibited, or Remote Auxiliary Setpoint is not programmed.

Remote Auxiliary Enable Logic

The Remote Auxiliary Setpoint input may be enabled from the 505 keypad, contact input, or Modbus communications. The last command given from any of these three sources dictates the state of the RAS input. A contact input can be programmed to enable and disable the Remote Auxiliary Setpoint input/function. When this contact is open the RAS is disabled, and when it is closed the RAS is enabled. The contact can be either open or closed when a trip condition is cleared. If the contact is open it must be closed to enable the RAS input. If the contact is closed it must be opened and re-closed to enable the RAS input.

When the Auxiliary PID is programmed to function as a limiter, the Remote Auxiliary Setpoint may be enabled at any time when the 505 is in the RUN mode.

When the Auxiliary PID is programmed as a Controller (enabled/disabled), there are three different options for enabling Remote Auxiliary Setpoint and Auxiliary control as follows:

- One Remote Enable contact input or function key command
- Both enable commands programmed; Remote Aux Enable and Auxiliary Enable
- No enable commands programmed

When only one Remote Enable command is programmed (either F-key or contact input), selecting 'Enable' will enable both Auxiliary control and Remote Auxiliary control. This configuration allows both functions to be enabled with one command if this is the normal operation mode. If 'Disable' is selected, both control modes are disabled.

When both Remote Auxiliary Enable and Auxiliary Control Enable commands are programmed, each function is enabled by its respective command selection. If Remote Auxiliary Enable is selected, only the Remote Auxiliary Setpoint will be enabled. If Auxiliary Control Enable is selected, only Auxiliary control will be enabled. If Remote Auxiliary Disable is selected, only the Remote Auxiliary Setpoint will be disabled. If Auxiliary Control Disable is selected, both Remote Auxiliary control and Auxiliary control will be disabled. However, if before the Auxiliary PID was 'In-control' an Auxiliary Disable command is given, only Auxiliary control will be disabled.

If no external contact input or function keys are programmed for the 'Enable' commands, Auxiliary Control and Remote Auxiliary Control must be enabled from either the front panel keypad or from Modbus. Since the front panel and Modbus provide both Remote Auxiliary Enable and Auxiliary Control Enable commands, they will operate in the same manner as 'both enables programmed'.

Refer to Volume 2 of this manual for information on related Service mode tunables. All pertinent Remote Auxiliary Setpoint parameters are available through the Modbus links. See Chapter 6 for a complete listing of Modbus parameters.

Valve Limiter

The valve limiter, limits the actuator output signal (governor valve position) to aid in starting up and shutting down the turbine. The output of the valve limiter is Low-Signal-Selected with the output of the Speed and Auxiliary PIDs. The PID or limiter asking for the lowest valve position will control valve position. Thus, the valve limiter, limits the maximum valve position.

The valve limiter can also be used to trouble shoot system dynamics problems. If it is believed that the 505 is the source of system instability, the valve limiter can be positioned to manually take control of the valve position. Care should be taken when using the valve limiter in this fashion, so as to not allow the system to reach a dangerous operating point.

The valve limiter level is adjusted through the 505 keypad, contact input, or through Modbus communications. When raise or lower commands are received, the limiter ramps up or down, at the 'VALVE LIMITER RATE'. The maximum the limiter can increase is 100%. The Valve Limiter 'Rate' and 'Max Valve position' settings can be adjusted in the Service mode.

The shortest length of time a setpoint will move for an accepted raise or lower command is 40 milliseconds (120 milliseconds for a Modbus command). If the Valve limiter slow rate is programmed for 10 %/sec, the smallest increment it will move is 0.4 % (.2 % for a Modbus command).

A specific setpoint may also be directly entered from the 505 keypad or through Modbus communications. When this is performed, the setpoint will ramp at the 'Valve Limiter Rate' (as defaulted in Service mode). To "enter" a specific setpoint from the 505 keypad, press the LMTR key to view the Valve Limiter screen, press the ENTER key, enter the setpoint level desired, then press the ENTER key again. If a valid number was entered, equal-to or between the min and max setpoint settings, the setting will be accepted and the Valve Limiter will ramp to the "entered" level. If an invalid number is "entered", the setting will not be accepted and the 505's screen will momentarily display a value out-of-range message.

When a valid setpoint value is entered, the setpoint will ramp at the 'Valve Limiter Rate' to the newly entered setpoint value. This 'Entered' rate is tunable through the Service mode.

Refer to Volume 2 of this manual for further information on Service mode and on-line tunables. All pertinent valve limiter parameters are available through the Modbus links. See Chapter 6 for a complete listing of Modbus parameters.

Emergency Shutdown

When an Emergency Shutdown condition occurs, the actuator output signal is stepped to zero milliamps, the Shutdown relay de-energizes, and the shutdown cause (first shutdown condition sensed) is displayed on the 505's front panel. Pressing the scroll down key from this screen will reveal any additional shutdown conditions that were sensed. See Chapter 5 for a detailed list of the possible shutdown (Trip) conditions.

Up to five Emergency Shutdown inputs (contact inputs) can be programmed to allow the 505 to indicate the cause of an emergency shutdown. By wiring trip conditions directly into the 505, instead of a trip string, the 505 can pass a trip signal directly to its output relay (to trip the T&T valve), and also indicate the first trip condition sensed. The 505's total throughput time is 20 milliseconds (worse case). All trip conditions are indicated through the 505's front panel, and Modbus communications.

The cause of the last trip can also be seen by pressing the 'CONT' key, then pressing the scroll down key. The last trip indication, is latched-in and can be viewed at any time after a trip and before the next trip condition is latched in. Once latched-in the last trip indication cannot be reset. This allows an operator to confirm what the trip condition was hours or days after the unit has been reset and restarted.

In addition to the dedicated Shutdown relay, the other programmable relays may be configured as Shutdown condition or Trip relays.

The Shutdown Condition relay may be programmed to indicate a shutdown condition on a remote panel or to a plant DCS. The Shutdown Indication relay is normally de-energized. This relay will energize upon any shutdown condition and stay energized until all trips have been cleared. The 'Reset Clears Trip' function has no effect on the programmable Shutdown Indication relay.

When programmed as a Trip relay, the respective relay will function like the dedicated Shutdown relay (normally energized and de-energizes on a shutdown) to indicate the position of the dedicated Shutdown relay.

Controlled Shutdown

The 505's Controlled Shutdown function is used to stop the turbine in a controlled manner, as opposed to an Emergency Trip. When a STOP command (controlled shutdown) is issued the following sequence is performed:

1. All control PIDs and functions are disabled except the Speed PID controller
2. The Speed Setpoint is ramped to zero at the speed setpoint slow rate
3. After the Speed Setpoint reaches zero, the valve limiter is instantly stepped to zero
4. When the valve limiter reaches zero, the 505 executes a Shutdown command
5. A "TRIP/Shutdown Complete" message is displayed on the 505 front panel

With the control in the run mode and the turbine turning, when the 505's "STOP" key is pressed, the control will display a message prompting the operator to verify the command (Manual Shutdown ?/Push YES or NO). At this point if the "YES" key is pressed the control will perform the controlled shutdown sequence explained above. Pushing the "NO" key will cause no change in the 505's operation, and the 'CONTROLLING PARAMETER' screen will be displayed. This verification feature prevents an unwanted shutdown if the STOP key is accidentally pushed.

A controlled shutdown can be initiated or aborted from the 505 front panel, a programmed contact input or either Modbus communication link. Verification is not required, if a controlled shutdown command is initiated by an programmed contact input or Modbus communication link.

The controlled shutdown sequence can be aborted at any time. During a controlled shutdown sequence, by pressing the STOP key, the 505 will display a 'Manual Shutdown In Ctrl/Push NO to Disable' message. Pressing the "NO" key from this screen will cause the shutdown sequence to be aborted, and the control to display a 'Manual Shutdown Stopped/Push YES to Continue' message. At this point the shutdown sequence can be re-initiated when desired, or the unit can be brought back to a fully operational state.

If an external contact is programmed to issue a controlled shutdown command, closing the contact will initiate the controlled shutdown sequence. The shutdown sequence will go through the same steps described above, with the exception that verification of the shutdown sequence is not needed. Opening the programmed contact will stop the sequence. The contact can be either open or closed when a trip condition is cleared. If the contact is open it must be closed to issue the command. If the contact is closed it must be opened and re-closed to issue the command. The Modbus initiated Control Shutdown Sequence requires two commands, one to start the sequence and the other to stop it.

The speed sensor failure trip, generator breaker open trip, and tie breaker open trip commands are overridden when a controlled shutdown is initiated.

**NOTE**

This command can be disabled through the Service Mode, if desired (see Key Options). When disabled, the Controlled Stop feature is disabled from front panel, Modbus, and contact commands.

See Chapter 5 of this Volume for all 505 service panel messages.

Overspeed Test Function

The 505's Overspeed Test function allows an operator to increase turbine speed above its rated operating range to periodically test turbine electrical and/or mechanical overspeed protection logic and circuitry. This includes the 505's internal overspeed trip logic and any external overspeed trip device's settings and logic. An Overspeed Test will allow the control's speed setpoint to be increased above the normal maximum governor limit. This test can be performed from the front panel of the control or with external contacts. This test is not permissible through the Modbus.

An overspeed test is allowed only under the following conditions:

- The Speed PID must be in control
- The Auxiliary, Cascade, and Remote Speed Setpoint PIDs/functions must be disabled
- If configured for a generator application the Generator breaker must be open.
- The Speed Setpoint must be at the, "Max Governor Speed" setting.

If the 'OSPD' key is pressed or an external Overspeed Test contact is closed (if programmed) and the above conditions are not met the control will display a "Overspeed Test/Not Permissible" message.

An overspeed test can be performed through an external contact, if the 'Overspeed Test' function is programmed to a 'Contact Input # Function' setting. When configured this contact performs the same function as the 505's front panel OSPD key.

There are two programmable relay options available to indicate overspeed status. One programmable relay option indicates an Overspeed Trip condition. The second relay option provides indication that an Overspeed Test is being performed.

See Chapter 5 of this manual for a complete Overspeed Test Procedure. All pertinent overspeed test parameters are available through the Modbus links. See Chapter 6 for a complete listing of Modbus parameters.

Local/Remote Function

The 505's Local/Remote function allows an operator at the turbine skid or 505 to disable any remote command (from a remote Control Room) that may put the system in a unsafe condition. This function is typically used during a system startup or shutdown to allow only one operator to manipulate the 505 control modes and settings.

The Local/Remote function must first be programmed before a Local or Remote mode can be selected by an operator. This function can be programmed under the OPERATING PARAMETERS BLOCK. If this function is not programmed all contact inputs and Modbus commands (when Modbus is programmed) are active at all times. If the Local/Remote function is programmed, Local and Remote modes can be selected through a programmed contact input, programmed function key (F3, F4), or Modbus command.

When Local mode is selected, the 505 is defaulted to be operable from its front panel only. This mode disables all contact inputs and Modbus commands, with exceptions noted below:

External trip Contact In	(defaulted in program)
External trip 2 Contact In	(active at all times, if programmed)
External trip 3 Contact In	(active at all times, if programmed)
External trip 4 Contact In	(active at all times, if programmed)
External trip 5 Contact In	(active at all times, if programmed)
Override MPU Fault Contact In	(active at all times, if programmed)
Frequency Arm/Disarm	(active at all times, if programmed)
Generator breaker Contact In	(active at all times, if programmed)
Utility tie breaker Contact In	(active at all times, if programmed)
Start permissive Contact In	(active at all times, if programmed)
Switched dynamics Contact In	(active at all times, if programmed)
Local/Remote Contact In	(active at all times, if programmed)
Local/Remote Modbus Command	(active at all times, if Modbus programmed)
Trip Command Modbus Command	(active at all times, if Modbus programmed)

When the Remote mode is selected the 505 can be operated through its front panel, contact inputs, and/or all Modbus commands.

When using a contact input to select between Local and Remote modes, a closed contact input selects the Remote mode and an open contact input selects the Local mode.

Optionally a relay can be programmed to indicate when Local mode is selected (energizes when the Local mode is selected). There is also indication of the Local/Remote mode selection through Modbus (address = true when the Remote mode is selected and false = when the Local mode is selected).

The 505 is defaulted to only allow control operation through its front panel when the Local mode is selected. If desired, this defaulted functionality can be changed through the 505's Service mode. The 505 can be modified to also allow operation through contacts inputs, or Modbus port #1 or Modbus port #2 when the Local mode is selected.

All pertinent local/remote control parameters are available through the Modbus links. See Chapter 6 for a complete listing of all Modbus parameters.

Function Keys

Function keys, F3 & F4 are located on the 505's front panel, and can be programmed independently to function as a control panel switch. These keys allow functions to be enabled and disabled from the 505's front panel, without requiring the use of an external switch. The following is a list of the programmable options for the function keys:

Local/Remote	Cascade Enable
Idle/Rated	Remote Cascade Setpoint Enable
Halt Continue Auto Start Seq	Auxiliary Enable
Remote Speed Setpoint Enable	Remote Auxiliary Setpoint Enable
Sync Enable	Relay Output
Frequency Control Arm/Disarm	

A two step process is required to enable or disable any function. Pressing a programmed function key will cause the 505's service panel to display the current state of the function and prompt the operator to press the YES or NO keys to enable or disable the function.

A function's prompt will change depending on the state of the function at that time. As an example, if the F3 key is programmed to allow an operator to enable and disable the 505's Remote Speed Setpoint, when the F3 key is pressed a (Push Yes to Enable/Rmt Spd Setpt Disabled) message will appear on the front panel display. Pressing YES will enable the Remote Speed Setpoint function and the message will change to (Push No to Disable/Rmt Spd Setpt In Control).

Relays

The 505 has eight relay outputs available. Two of these relays are dedicated; one for a system shutdown command from the 505 and one for alarm indication. The other six relays can be programmed for a variety of indications, and system functions.

For fail-safe operation, the dedicated Shutdown relay is energized during normal system operation, and will de-energize when a shutdown occurs.

The dedicated Alarm relay is normally de-energized. This relay will energize upon an alarm condition and stay energized until the alarm condition is cleared. Optionally this relay can be configured, through the 505's Service mode, to toggle on and off repeatedly when an alarm conditions has occurred. With this configuration if a reset command is given and the alarm condition still exists, the relay will stop toggling and stay energized. The relay will start toggling again, upon a new alarm condition. This option can be used to inform the operator when another alarm condition has occurred.

Any of the other six relays can be programmed to function as a level switch or mode indication. When programmed as a level switch the relay will change state when the selected parameter reaches the programmed level (energizes when value is higher the programmed level). The following is a list of the 505's relay options for level indication:

Speed	Aux Setpoint
Speed Setpoint	Actuator Demand
KW Input	Actuator 1 Demand
Sync/Load Share Input	Actuator 2 Demand
Cascade Input	Valve Limiter
Casc Setpoint	First Stage Pressure
Aux Input	

The present relay state (energized/de-energized) and relay configuration is indicated through both Modbus communication links.

Relays not used as level switches can be programmed to indicate control states. Except for the Trip relay, when programmed to indicate a state or event, relay will energize upon the respective state or event occurring. The following is a list of options for relays if used to indicate a control mode or state:

Shutdown Condition	Sync Enabled
Trip Relay (additional trip relay output)	Sync or Load Share Enabled
Alarm Condition	Load Share Control Enabled
505 Control Status OK	Casc Control Enabled
Overspeed Trip	Cascade Control Active
Overspeed Test Enabled	Remote Casc Setpt Enabled
Speed PID in Control	Remote Casc Setpt Active
Remote Speed Setpt Enabled	Aux Control Enabled
Remote Speed Setpt Active	Aux Control Active
Underspeed Switch	Auxiliary PID in Control
Auto Start Sequence Halted	Remote Aux Setpt Enabled
On-Line PID Dynamics Mode	Remote Aux Setpt Active
Local Control Mode	Valve Limiter in Control
Frequency Control Armed	F3 Key Selected
Frequency Control	F4 Key Selected
Modbus Command	

Relay Clarifications

The Shutdown Condition relay may be programmed to indicate a shutdown condition on a remote panel or to a plant DCS. The Shutdown Indication relay is normally de-energized. This relay will energize upon any shutdown condition and stay energized until all trips have been cleared. The 'RESET CLEAR TRIP' function has no effect on the programmable Shutdown Indication relay.

When programmed as a Trip relay, the respective relay will function like the dedicated "Shutdown" relay (normally energized and de-energizes on a shutdown) to indicate the position of the dedicated Shutdown relay. This relay output can be programmed to indicate a 505 initiated trip by setting the 'Ext trips in Trip Relay' option to NO. Using this option, 505 trip annunciation will only occur if the 505 tripped the turbine and not annunciate when the other external devices shuts down the unit (external trips).

The Alarm Condition relay may be programmed to indicate an alarm condition on a remote control panel or to a DCS. The Alarm Indication relay is normally de-energized. This relay will energize upon any alarm condition and stay energized until all alarms have been cleared. If the 'BLINK ALARMS' option is 'YES' the programmable Alarm Condition relay will toggle on and off repeatedly when an alarm condition has occurred. With this configuration if a reset command is given and the alarm condition still exists, the relay will stop toggling and stay energized.

The 505 Control Status OK relay is normally energized, and will only de-energize if unit inlet power is lost, the 505's CPU fails, or the 505 is in the program mode.

The Overspeed Test Enable relay will energize when an Overspeed Test is performed. This relay functions like the 505 OSPD key's LED (it repeatedly toggles on and off when turbine speed is above the turbine Overspeed trip setting).

An Underspeed Switch function can be programmed to indicate a turbine underspeed or overpower condition. If the Underspeed option is configured, once turbine speed reaches a level above the minimum governor speed setting, then decreases 100 rpm below the minimum governor speed setting, the respective relay energizes (indicating an underspeed condition). The 'Underspeed setting' is adjustable through the Service mode, under the 'Speed Values' header.

When the Sync Enabled function is programmed, the assigned relay energizes when a synchronize command is given. After the unit generator or utility tie breaker is closed this function becomes disabled and the relay de-energizes. The 505's Synchronization function can be used to synchronize across a generator breaker or utility tie breaker.

When the Sync or Load Share Active function is programmed, the assigned relay energizes when a synchronizing or Load Sharing is active. When both the generator and utility tie breaker inputs are closed (Load Sharing not selected) this function becomes disabled and the relay de-energizes.

When the (F3,F4) Key Selected function is programmed, the assigned relay energizes when the respective function key is pressed and an enable/disable command issued. This feature allows the 505's F3 and F4 function keys to be used as panel switches to select and/or enable system related functions (synchronizers).

When the Modbus Command function is programmed, the assigned relay energizes when the respective Modbus command "Turn On Modbus Relay X" is issued, then de-energizes when the respective Modbus command "Turn Off Modbus Relay X" is issued. This feature allows a 505 relay to be driven directly from Modbus to control a system related function (synchronizing). In addition, the assigned relay can be momentarily energized using the Modbus command "Momentarily Energize Modbus Relay X" is issued (voltage raise/lower commands). Refer to Chapter 6 of this manual for more information on Modbus commands.

Chapter 4. Configuration Procedures

Program Architecture

The 505 is easy to program, due in large part to the menu-driven software. Basic program architecture is illustrated in Figure 4-1. When the control is powered up, and after the brief CPU self test has been completed, the control displays a ready status (Controlling Parameter/Push Run or Program). The operating procedures are divided into two sections: the Program Mode (Figure 4-3) and the Run Mode (refer to Chapter 5 for RUN Mode information). The Program Mode is used to configure the 505 for the specific application and set all operating parameters. The Run Mode is the normal turbine operation mode and is used to view operating parameters and run the turbine.

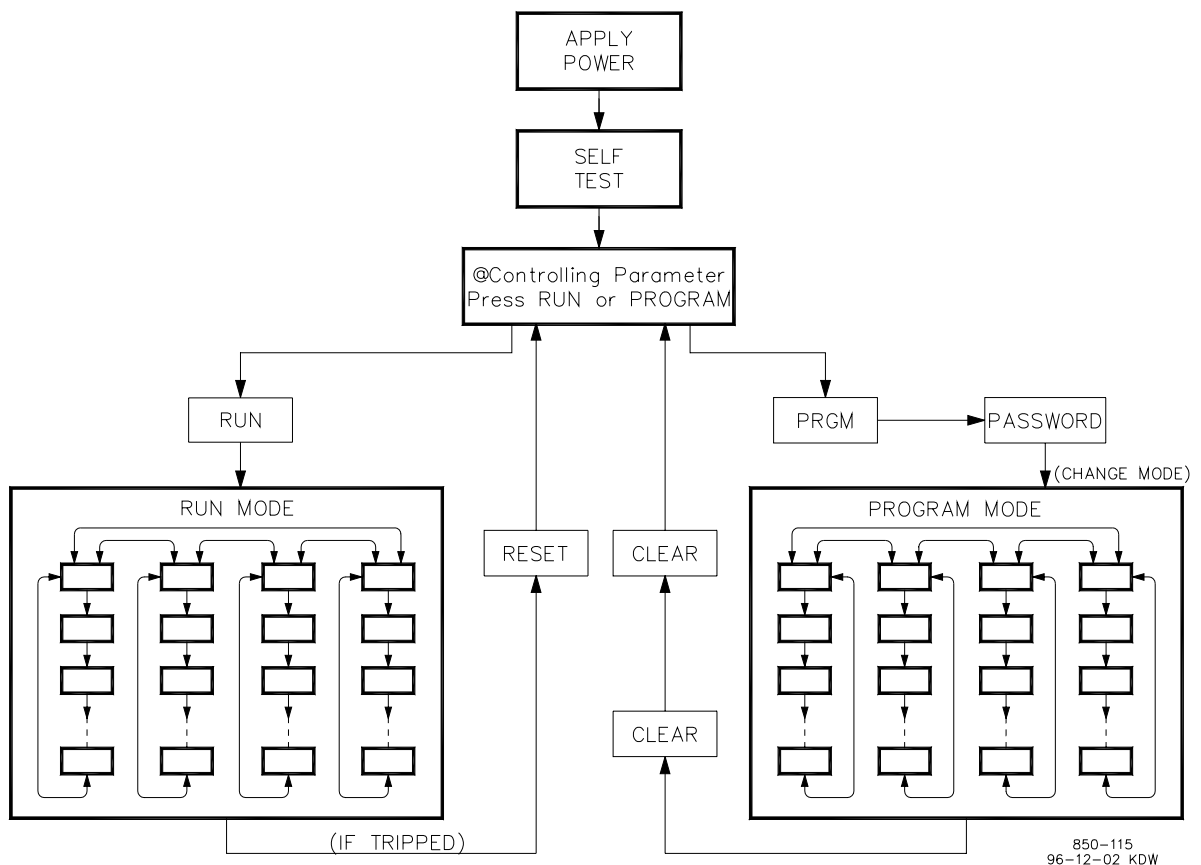

Figure 4-1. Basic Program Architecture

The program cannot be changed or altered while the turbine is running, however, it can be accessed and all programmed values monitored. This minimizes the possibility of introducing step disturbances into the system. To monitor or review the program while in the run mode, simply press the 'PRGM' key then step across or step down as necessary. If a wrong key is pressed the display will revert to the last screen displayed before entering the program mode or the screen designated to the key pressed.

The touch keypad has several dual-function keys. Pushing any dual-function key in the Program Mode enters the appropriate numeric or yes/no value printed on the key. Pushing the key in the Run Mode enters the operating parameter printed on the key, unless the "ENTER" key has been pressed to enter a specific numeric setpoint value.

Programming the 505

Before the 505 can be used to operate any turbine, it must be configured with a valid program. A handy 505 Program Mode Worksheet is provided at the end of this manual. This chapter contains additional information related to completing this worksheet and programming the specific application. It is recommended that this worksheet be completed and used to document your specific program.

Figure 4-2 illustrates the 505 screens displayed when power is applied and how to enter the Program Mode from this point. The password is required to protect against both intentional and inadvertent program changes. The password can be changed if desired, refer to Volume 2 for information on changing passwords.

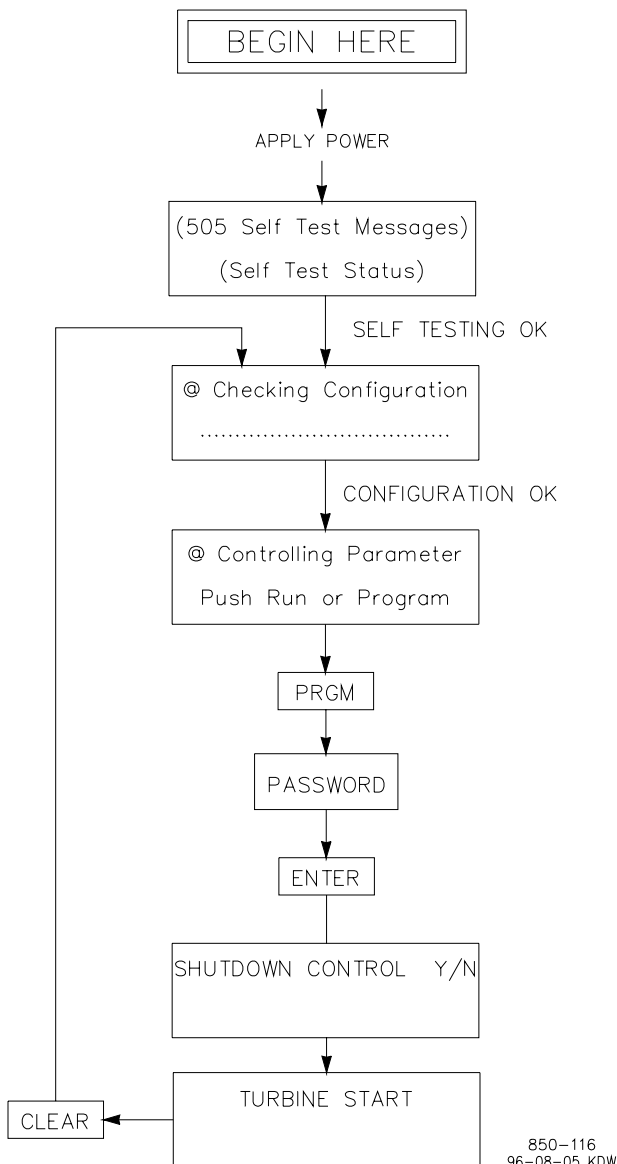

850-116
96-08-05 KDW

Figure 4-2. Initial 505 Program Mode Entry

The 505 program mode (configuration) may be accessed once the configuration check is complete and the turbine is not running. For safety reasons the program may be monitored only and no changes will be accepted if the turbine is running. By pressing the PRGM key and entering the password (1113) then pressing ENTER on the 505 keypad the SHUTDOWN CONTROL Y/N prompt will appear. If YES is pressed the 505 will issue a shutdown and the program mode will be accessed. If NO is pressed the 505 will revert to the Select Mode screen and the program mode will not have been accessed.

All configuration (program mode) values and saved service mode changes are stored in the nonvolatile memory (EEPROMs) of the 505 control. If power is removed from the 505 all saved values will return once power is restored. No batteries or back up power is required.

**CAUTION**

The field-configured portion of the program will be zeroed out after factory repair. To prevent damage to your equipment, you must reconfigure the Program Mode before the unit is put back into service.

Using Program Menus

Once the Program Mode has been entered with the password, the specific application information must be entered into the 505. Figure 4-3 illustrates the 505 configuration menus and the questions/options available under each header/column.

The arrow keys (SCROLL LEFT, SCROLL RIGHT) allow you to move right or left across the tops of the function the Program mode columns. The SCROLL UP and SCROLL DOWN keys allow you to move up or down the columns. In the Program Mode, the control will not step down beyond the current step with an invalid entry (or with no entry). A valid entry must be made before the control will allow you to step down to the next parameter.

The control displays previously entered values with each program step. If a displayed value is satisfactory, press the SCROLL UP, SCROLL DOWN, or ENTER keys to continue. If a new value is required, enter it, then press ENTER. The ENTER key must be pressed to enter any new value. Also, when the ENTER key is pressed, the control will automatically advance to the next step.

To return to the header of a program block, press the CLEAR key. To completely exit out of the Program Mode, press the CLEAR key from the top of the header. This will save the programmed values and initiate the program configuration check procedure.

All steps in the program must contain valid entries. The default values are listed along with any adjustment ranges, where applicable. If an invalid entry is made, the control displays an invalid entry message. If ENTER is pressed, the control displays the program step again so a valid entry can be made.

Program Blocks

Figure 4-3 shows the 13 program columns. To program the control, simply step through the blocks as described above and configure the control features for the desired application. The first seven program columns must be programmed for every installation. The remaining six columns contain optional features which can be selected if desired. The 13 columns and their basic functions are described in detail below.

Required Configuration Blocks:

Turbine Start–	to configure start mode, idle/rated, and auto start sequence settings;
Speed Control–	to configure MPU or PROX PROBE information and speed control dynamics settings;
Speed Setpoint Values–	to configure speed setpoints, overspeed trip setpoint, remote speed setting control and critical speed avoidance bands;
Operating Parameters–	to configure the unit for generator application and to use the local/remote function;
Driver Configuration–	to configure driver outputs and, if not using driver 2, to use driver 2 for a 4–20 mA readout;
Analog Inputs–	to configure analog input options;
Contact Inputs–	to configure contact input options;

Optional Configuration Blocks:

Function Keys–	to configure F3 and F4 function keys options;
Auxiliary Control–	to configure auxiliary control information;
Cascade Control–	to configure pressure, temperature control information;
Readouts–	to configure analog readout options;
Relays–	to configure relay options;
Communications–	to configure Modbus communication options.

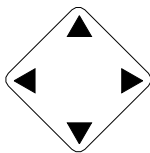
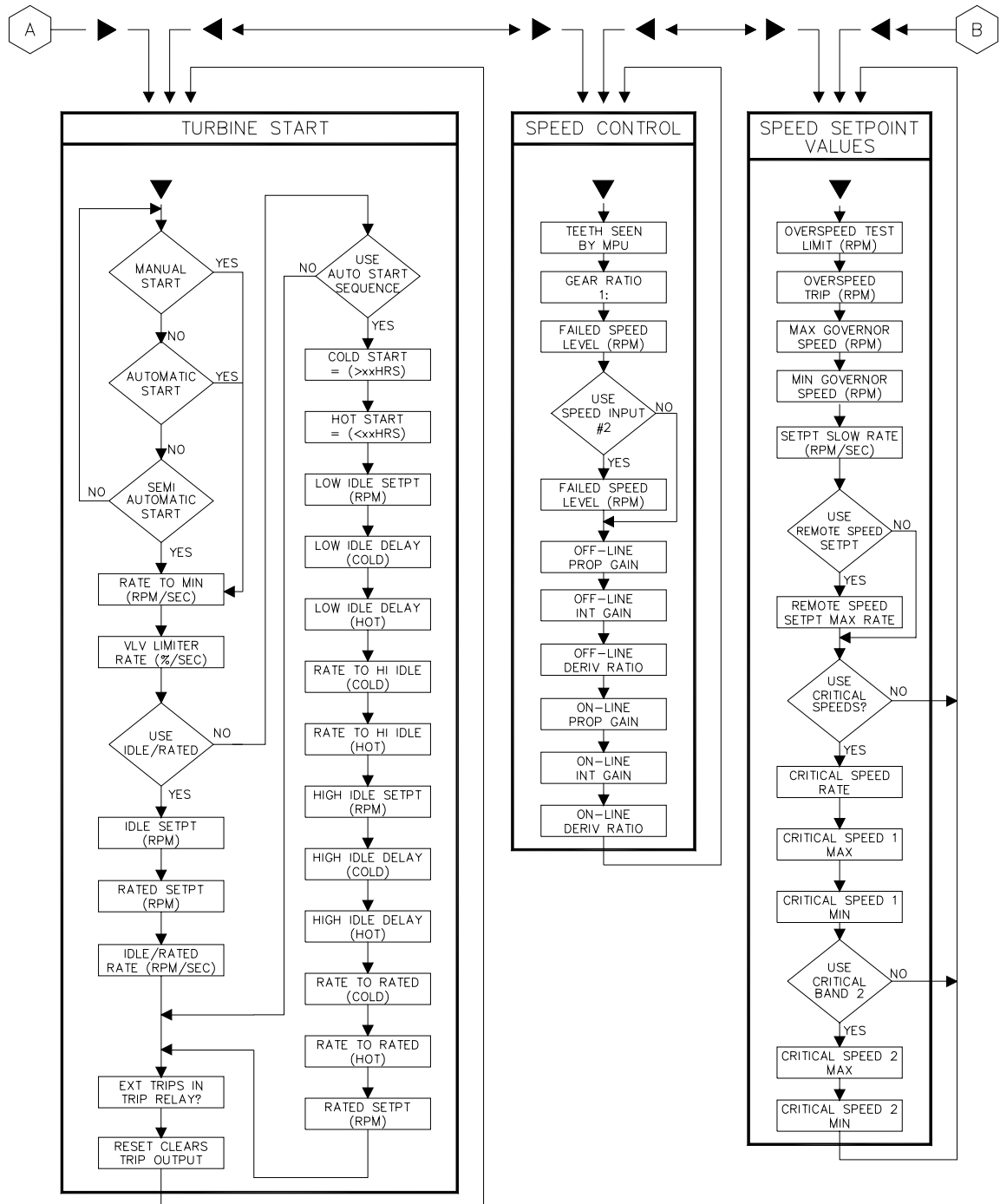

LEFT AND RIGHT ARROWS
MOVE THE PROGRAM
POINTER BACK AND FORTH
ACROSS THE TOP OF THE
FUNCTION BLOCKS.

UP AND DOWN ARROWS
MOVE THE PROGRAM
UP AND DOWN THE
FUNCTION BLOCKS.

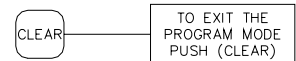

850-087A
97-08-05 JMM

Figure 4-3a. Program Mode Blocks

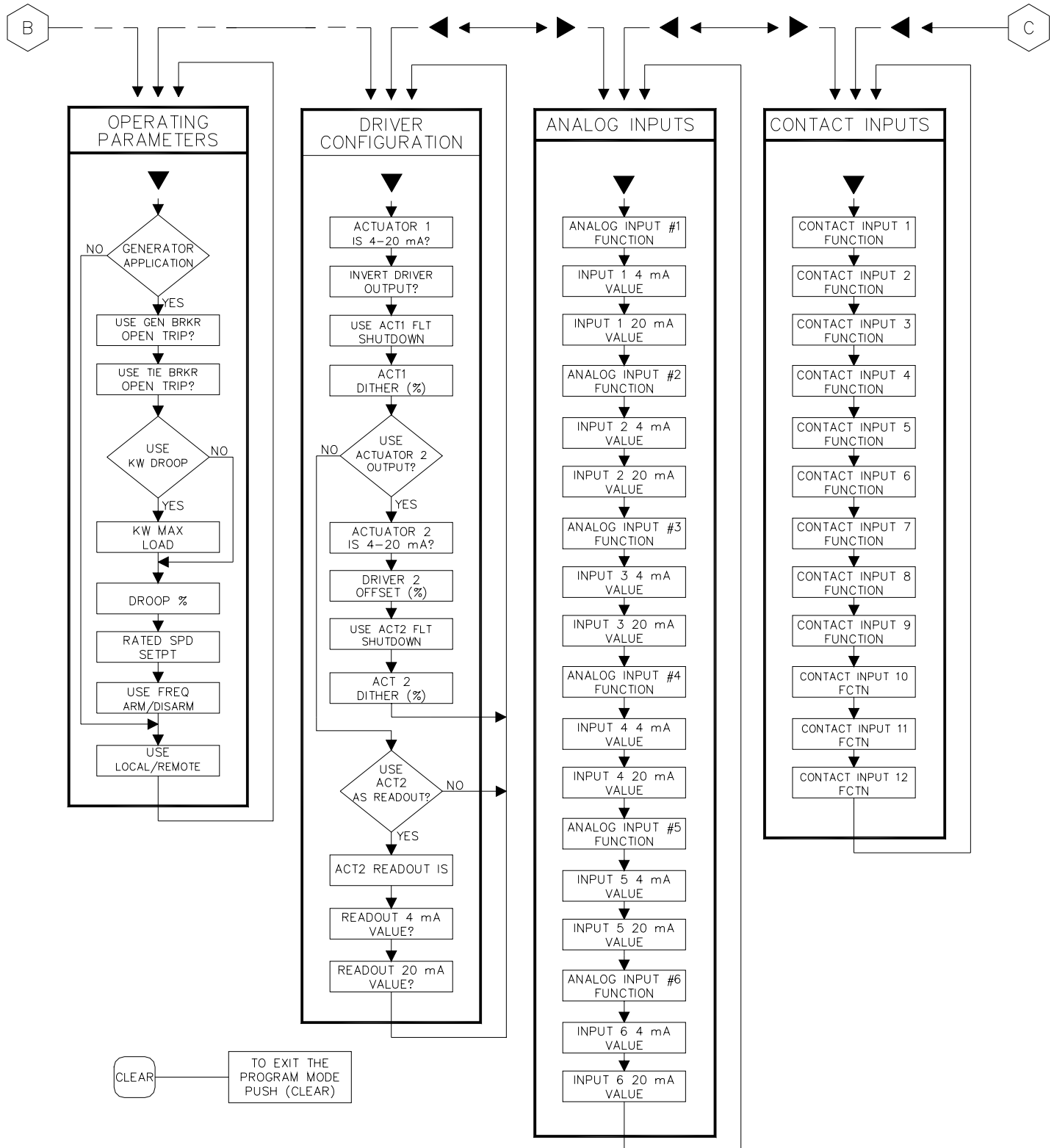

850-088a
97-08-05 JMM

Figure 4-3b. Program Mode Blocks

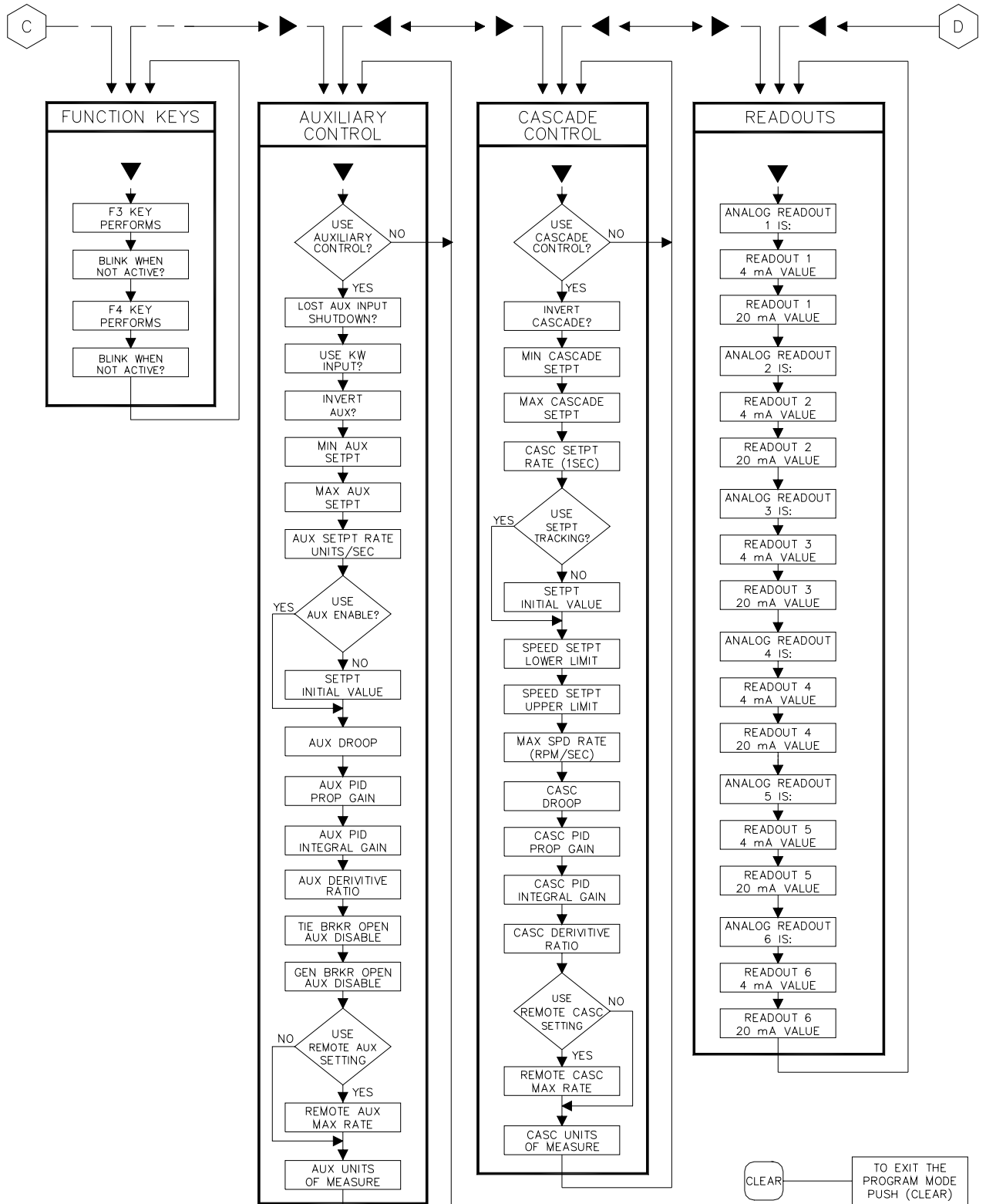

Figure 4-3c. Program Mode Blocks

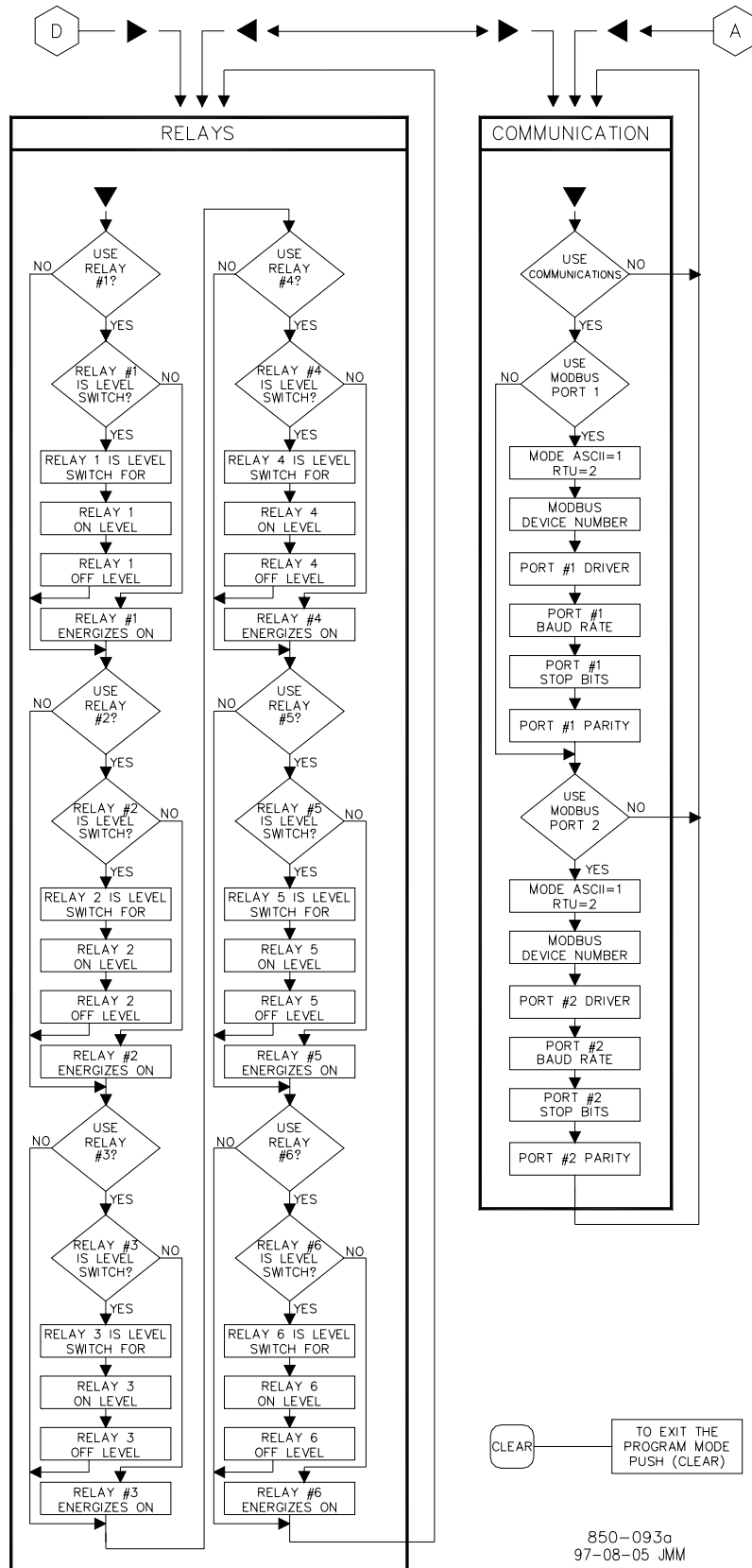

Figure 4-3d. Program Mode Blocks

Each of the program blocks are described in detail below. Figure 4-3 can be referred to for a graphical program block reference. After a column has been configured and the display is back at the top of the column, use the left or right arrow keys to select the next column to configure or check.

All control program questions will be displayed on the top line of the display; all entries made will be displayed on the lower line of the display. At the beginning of each column the control will display the header, pushing the down arrow will access the column.

The program blocks (Figure 4-3) contain information detailing each question and/or 505 program configuration option. Each question/option shows the default (dflt) value and the adjustable range of that parameter (shown in parentheses). In addition, any additional constraints on the configuration are shown in italics following the description. There is a program mode worksheet in the appendix of this manual that should be completed/filled-in and used as a guide for your particular application. This worksheet can also be used for future reference to document your application program.

Turbine Start Block

When this header appears in the display, press the down arrow key to configure this block or press a left or right arrow key to select another block to configure.

MANUAL START? dflt= NO (Yes/No)

Select YES followed by the ENTER key to configure a manual start mode. When configured for a manual start mode, the operator controls the turbine speed from zero up to the minimum control speed using an external trip-throttle valve. The Manual Start Sequence would be: Push RUN. The actuator(s) automatically move to max position. Lastly, the operator slowly opens the trip-throttle valve until the governor takes control.

AUTOMATIC START? dflt= NO (Yes/No)

Select YES followed by the ENTER key to configure an automatic start mode. When configured for an automatic start mode, the 505 controls the turbine speed from zero up to the minimum control speed. The Automatic Start Sequence would be: Operator opens the T&T valve, then push RUN. The valve limiter opens automatically until the governor takes control.

SEMIAUTOMATIC START? dflt= NO (Yes/No)

Select YES followed by the ENTER key to configure a semiautomatic start mode. When configured, the 505 valve limiter must be manually opened by the operator, slowly, to open the control valve and bring the turbine speed from zero up to the minimum control speed. The Semi-automatic Start Sequence would be: Open the T&T valve, then push RUN. The valve limiter must then be raised by the operator until governor takes control.

(One of the three start modes must be selected before the unit will run.)

RATE TO MIN (rpm/sec) dflt= 10.0 (0.01, 2000)

Enter the speed setpoint acceleration rate to minimum followed by the ENTER key. This is the rate the setpoint moves from zero to the lowest controlling speed on a start command (assuming the turbine is at zero speed). The minimum controlling speed will be either 'idle' if idle/rated is used or 'low idle' if the auto start sequence is used. If neither of these startup features is used, the min speed will be the minimum governor speed setpoint.

- VALVE LIMITER RATE (%/sec)** dflt= 5.0 (0.1, 25)
 Enter the Valve Limiter Rate, in percent per second, followed by ENTER.
 This is the rate at which the valve limiter moves when RUN is selected or when the limiter setting is changed through open/close commands. When using a semiautomatic or automatic start, this setting should be very slow—typically less than 2 %/sec. When using a manual start, this setting is less critical and can be left at the default of 5 %/sec.
- USE IDLE/RATED ?** dflt= NO (Yes/No)
 Select YES followed by ENTER if this function is desired. If NO, skip to 'Use Auto Start Sequence'. If YES is selected, the control will ramp from a programmable Idle speed to a programmable Rated speed setpoint when Rated is selected through keypad, Modbus or external switch.
- IDLE SETPT (rpm)** dflt= 1000 (0.0, 20000)
 Enter the Idle Speed setpoint desired followed by the ENTER key. This is the lowest speed control setpoint when using the Idle/Rated function.
- RATED SETPT (rpm)** dflt= 3600 (0.0, 20000)
 Enter the Rated Speed setpoint desired followed by the ENTER key. This is the speed control setpoint that the unit accelerates to when using the Idle/Rated function.
(Must be greater than or equal to the 'Minimum Governor Speed' Setting)
- IDLE/RATED SETPT RATE (rpm/sec)** dflt= 5.0 (0.01, 2000)
 Enter the Idle/Rated rate (rpm/second) followed by ENTER. This is the at which the speed setpoint moves between Idle and Rated speed setpoints when using the Idle/Rated commands.
- USE AUTO START SEQUENCE ?** dflt= NO (Yes/No)
 Enter YES followed by ENTER if this function is desired. If NO is selected followed by ENTER, then the program will step to 'Reset Clears Trip Output' question. If this function is programmed and RUN is selected, the 505 automatically accelerates the speed setpoint to a programmable low idle speed and holds for a programmable time then ramps to a programmable high idle speed and holds for a programmable time then ramps to programmable rated speed setpoint. The start sequence can be actuated or halted through the keypad, Modbus or external switch.
- COLD START (> xx HRS)** dflt= 10 (0.0, 200)
 Enter the time in hours allowed after a trip before the 'cold start' sequence curves are to be used followed by the ENTER key. If this much time has expired (or more) after a trip condition, then the control will use the cold start values. If less than this time has expired, the control will interpolate between the hot and cold start values to determine rates and hold times.
- HOT START (< xx HRS)** dflt= 1.0 (0.0, 200)
 Enter the maximum time allowed after a trip for the 'hot start' sequence curves to be used followed by the ENTER key. If less than this time has expired after a trip condition, then the control will use the hot start values.
(Must be less than or equal to the 'Cold Start' Hours)
- LOW IDLE SETPT (rpm)** dflt= 1000 (0.0, 20000)
 Enter the Low Idle Speed Setting followed by the ENTER key. This is the first hold speed when using the automatic start sequence. The speed setpoint will remain at this setting until the low idle delay/hold time has expired.
- LOW IDLE DELAY TIME—COLD (MINUTES)** dflt= 1.0 (0.0, 500)
 Enter the cold start hold time desired at low idle followed by ENTER. This is the programmable time, in minutes, that the turbine will wait/hold at the low idle speed when a cold start is determined.

- LOW IDLE DELAY TIME- HOT (MINUTES) dflt= 1.0 (0.0, 500)
 Enter the hot start hold time at low idle followed by ENTER. This is the programmable time, in minutes/seconds, that the turbine will wait/hold at the low idle speed when a hot start is determined. If the turbine has been shutdown for longer than the Hot time but shorter than the Cold time, the control will interpolate between the Hot and Cold delays to determine the low idle hold time.
(Must be less than or equal to the 'Low Idle Delay—Cold' Setting)
- RATE TO HI IDLE—COLD (rpm/sec) dflt= 5.0 (0.01, 500)
 Enter the cold start rate to high idle followed by ENTER. This is the programmable rate, in rpm per second, that the speed setpoint will accelerate at when moving to high idle when a cold start is determined.
- RATE TO HI IDLE—HOT (rpm/sec) dflt= 5.0 (0.01, 500)
 Enter the hot start rate to high idle followed by ENTER. This is the programmable rate, in rpm per second, that the speed setpoint will accelerate at when moving to high idle when a hot start is determined. If the turbine has been shutdown for longer than the Hot time but shorter than the Cold time, the control will interpolate between the Hot and Cold rates to determine the acceleration rate to the hi idle setpoint.
(Must be greater than or equal to the 'Rate to Hi Idle—Cold' Setting)
- HI IDLE SETPT (rpm) dflt= 2000 (0.0, 20000)
 Enter the Hi Idle Speed Setting followed by the ENTER key. This is the second hold speed when using the automatic start sequence. The speed setpoint will remain at this setting until the Hi Idle Delay/hold time has expired.
(Must be greater than the 'Low Idle' Setting)
- HI IDLE DELAY TIME—COLD (MINUTES) dflt= 1.0 (0.0, 500)
 Enter the cold start hold time desired at hi idle followed by ENTER. This is the programmable time, in minutes, that the turbine will wait/hold at the hi idle speed when a cold start is determined.
- HI IDLE DELAY TIME—HOT (MINUTES) dflt= 1.0 (0.0, 500)
 Enter the hot start hold time desired at hi idle followed by ENTER. This is the programmable time, in minutes, that the turbine will wait/hold at the hi idle speed when a hot start is determined. If the turbine has been shutdown for longer than the Hot time but shorter than the Cold time, the control will interpolate between the Hot and Cold delays to determine the hi idle hold time.
(Must be less than or equal to the 'Hi Idle Delay—Cold' Setting)
- RATE TO RATED SETPT—COLD (rpm/sec) dflt= 5.0 (0.01, 500)
 Enter the cold start rate to the rated speed setpoint followed by ENTER. This is the programmable rate, in rpm per second, that the speed setpoint will accelerate at when moving to rated when a cold start is determined.
- RATE TO RATED SETPT—HOT (rpm/sec) dflt= 5.0 (0.01, 500)
 Enter the hot start rate to the rated speed setpoint followed by ENTER. This is the programmable rate, in rpm per second, that the speed setpoint will accelerate at when moving to rated when a hot start is determined. If the turbine has been shutdown for longer than the Hot time but shorter than the Cold time, the control will interpolate between the Hot and Cold rates to determine the acceleration rate to the rated setpoint.
(Must be greater than or equal to the 'Rate to Rated—Cold' Setting)
- RATED SETPT (rpm) dflt= 3600 (0.0, 20000)
 Enter the Rated Speed Setting followed by the ENTER key. This is the final speed setting when using the automatic start sequence. Once this speed setpoint is reached, the start sequence is complete.
(Must be greater than or equal to the 'Minimum Governor' Setting)

- AUTO HALT AT IDLE SETPTS?** dflt= NO (Yes/No)
 Select YES followed by the ENTER key to automatically halt the auto start sequence at the idle setpoints. This feature would result in the unit automatically stopping/halting at the low idle setpoint and at the high idle setpoint. Also, if the unit is started and the speed is above the low idle setpoint, the sequence will be halted. Select NO to allow the control to perform its automatic start sequence routine without interruption.
- EXTERNAL TRIPS IN TRIP RELAY ?** dflt= YES (Yes/No)
 Select YES followed by the ENTER key to allow the external trip input(s) to de-energize the Trip Relay output. When set to NO, an external trip contact input to the 505 will shut down the 505 control but will not de-energize the 505's trip relay output.
- RESET CLEARS TRIP OUTPUT ?** dflt= NO (Yes/No)
 Select YES followed by the ENTER key to configure the Reset Clears Trip Relay output function. When set to YES, a Reset command will energize the trip relay output even when a trip condition is still sensed by the 505—typically due to one of the external trip inputs. Once reset, the unit will be 'Ready to Start' as soon as all external trip inputs are closed. When NO, the trip relay output will be de-energized on a 505 trip and will not energize until all trips have cleared and a 'Reset' command is given.

Speed Control Block

When this header appears in the display, press the down arrow key to configure this block or press a left or right arrow key to select another block to configure.

(The maximum turbine speed is 20000 rpm and the maximum speed input frequency is 15000 hertz.)

- TEETH SEEN BY MPU** dflt= 60.0 (1, 300)
 Enter the number of teeth on gear that the speed probe is mounted on followed by the ENTER key.
- MPU GEAR RATIO** dflt= 1.0 (0.05, 100)
 Enter the speed sensor gear ratio followed by the ENTER key. This value is the ratio of the speed sensor gear to the turbine shaft. This gear ratio is the result of dividing the speed of the speed sensor gear by the speed of the turbine shaft.
- FAILED SPEED LEVEL (rpm)** dflt= 250 (0.5, 1000)
 Enter the Failed Speed Level (in rpm) followed by the ENTER key to set the speed probe input failure level. If speed drops below this level, the control will determine the speed input device is failed and issue an alarm. If all speed inputs fail, the 505 will issue a trip on loss of speed inputs.
(Must be greater than or equal to 0.0204 x Overspeed Test Limit Setting)
- USE SPEED INPUT #2?** dflt= NO (Yes/No)
 Select YES followed by ENTER if both speed inputs are to be used.
- FAILED SPEED LEVEL (rpm)** dflt= 250 (0.5, 1000)
 Enter the failed speed level (in rpm) followed by the ENTER key to set the speed probe input failure level. If speed drops below this level, the control will determine the speed input device is failed and issue an alarm. If all speed inputs fail, the 505 will issue a trip on loss of speed inputs.
(Must be greater than or equal to 0.0204 x Overspeed Test Limit Setting)

- OFF-LINE PROPORTIONAL GAIN** dflt= 5.0 (0.0, 100)
 Enter the off-line PID proportional gain percentage followed by ENTER. This value is used to set speed/load control response when the Generator or Utility Tie breaker contacts are open (if the unit is a generator) or if the turbine speed is below minimum governor speed (if the unit is not a generator) or when the Select Dynamics function is used and the contact is open. This value can be changed in the Run Mode while the turbine is operating. A recommended starting value is 5%.
- OFF-LINE INTEGRAL GAIN** dflt= 0.5 (0.01, 50)
 Enter the off-line PID integral gain percentage followed by ENTER. This value is used to set speed/load control response when the Generator or Utility Tie breaker contacts are open (if the unit is a generator) or if the turbine speed is below minimum governor speed (if the unit is not a generator) or when the Select Dynamics function is used and the contact is open. This value can be changed in the Run Mode while the turbine is operating. A recommended starting value is 0.5%.
- OFF-LINE DERIVATIVE RATIO** dflt= 5.0 (0.01, 100)
 Enter the off-line PID derivative ratio followed by ENTER. This value is used to set speed/load control response when the Generator or Utility Tie breaker contacts are open (if the unit is a generator) or if the turbine speed is below minimum governor speed (if the unit is not a generator) or when the Select Dynamics function is used and the contact is open. This value can be changed in the Service Mode while the turbine is operating. A recommended starting value is 5% .
- ON-LINE PROPORTIONAL GAIN** dflt= 5.0 (0.0, 100)
 Enter the on-line PID proportional gain percentage followed by ENTER. This value is used to set speed/load control response when the Generator and Utility Tie breaker contacts are closed (if the unit is a generator) or if the turbine speed is above minimum governor speed (if the unit is not a generator) or when the Select Dynamics function is used and the contact is closed. This value can be changed in the Run Mode while the turbine is operating. A recommended starting value is 5%.
- ON-LINE INTEGRAL GAIN** dflt= 0.5 (0.01, 50)
 Enter the on-line PID integral gain percentage followed by ENTER. This value is used to set speed/load control response when the Generator and Utility Tie breaker contacts are closed (if the unit is a generator) or if the turbine speed is above minimum governor speed (if the unit is not a generator) or when the Select Dynamics function is used and the contact is closed. This value can be changed in the Run Mode while the turbine is operating. A recommended starting value is 0.5%.
- ON-LINE DERIVATIVE RATIO** dflt= 5.0 (0.01,100)
 Enter the on-line PID derivative ratio followed by ENTER. This value is used to set speed/load control response when the Generator and Utility Tie breaker contacts are closed (if the unit is a generator) or if the turbine speed is above minimum governor speed (if the unit is not a generator) or when the Select Dynamics function is used and the contact is closed. This value can be changed in the Service Mode while the turbine is operating. A recommended starting value is 5% (see Chapter 5—PID Dynamics Settings for more information).

Speed Setpoint Values Block

When this header appears in the display, press the down arrow key to configure this block or press a left or right arrow key to select another block to configure.

(The maximum turbine speed is 20000 rpm and the maximum speed sensor input frequency is 15000 hertz.)

- OVERSPEED TEST LIMIT (rpm) dflt= 1100 (0.0, 20000)
Set the overspeed test limit (in rpm) followed by the ENTER key. This is the maximum speed setpoint the control will increase to when overspeed testing the unit. The setpoint can only be raised to this level when the overspeed test function is being performed.
- OVERSPEED TRIP LEVEL (rpm) dflt= 1000 (0.0, 20000)
Set the 505's overspeed trip level (in rpm) followed by the ENTER key. This is the governor overspeed trip setpoint only and is not to be used as ultimate overspeed protection.
(Must be less than the 'Overspeed Test Limit' Setting)
- MAX GOVERNOR SPEED SETPOINT (rpm) dflt= 0.0 (0.0, 20000)
Set the maximum governor control speed followed by the ENTER key. This is the normal governor operation upper limit. For turbine/generator applications, this value must be at least equal to [Rated Speed + (Droop % x Rated Speed)].
(Must be less than the 'Overspeed Trip Level' Setting)
- MIN GOVERNOR SPEED SETPOINT (rpm) dflt= 0.0 (0.0, 20000)
Set the minimum governor control speed followed by the ENTER key. This is the normal governor operation lower limit.
(Must be less than the 'Maximum Governor Speed' Setting)
- SPEED SETPOINT SLOW RATE (rpm/sec) dflt= 5.0 (0.01, 100)
Enter the speed setpoint slow rate in rpm per second followed by the ENTER key. This the rate of speed change for normal operation.
- USE REMOTE SPEED SETPOINT ? dflt= NO (Yes/No)
Set to YES followed by ENTER if using an analog input to set the Speed/Load Setpoint.
- RMT SPEED SETPT MAX RATE (rpm/sec) dflt= 50.0 (0.01, 500)
Enter the Maximum Rate of speed change for remote speed setpoint operation followed by the ENTER key.
- USE CRITICAL SPEEDS ? dflt= NO (Yes/No)
Set to YES followed by ENTER to use the critical speed avoidance logic. When set to YES, allows up to two critical speed avoidance bands to be programmed. Within the band, the speed setpoint cannot be stopped. These bands are used to protect the turbine and driven device from speeds that have inherently high vibration.
(Must program either 'Idle/Rated' or 'Auto Start Sequence' to use critical speed avoidance. The lowest critical speed min must be greater than idle or low idle.)
- CRITICAL SPEED RATE (rpm/sec) dflt= 50.0 (0.1, 2000)
Set the rate that the speed setpoint will move through the critical speed avoidance ranges (in rpm/second) followed by the ENTER key
(Must be greater than the 'Speed Setpt Slow Rate' Setting)
- CRITICAL SPEED 1 MAX (rpm) dflt= 1.0 (1.0, 20000)
Set the upper limit of the critical speed avoidance band followed by the ENTER key.
(Must be less than the 'Minimum Governor Speed' Setting)
- CRITICAL SPEED 1 MIN (rpm) dflt= 1.0 (1.0, 20000)
Set the lower limit of the critical speed avoidance band followed by the ENTER key.
(Must be less than the 'Critical Speed 1 Max' Setting)
- USE CRITICAL SPEED 2 ? dflt= NO (Yes/No)
Select YES followed by the ENTER key to use the second critical speed avoidance band.
- CRITICAL SPEED 2 MAX (rpm) dflt= 1.0 (1.0, 20000)
Set the upper limit of the critical speed avoidance band followed by the ENTER key.
(Must be less than the 'Minimum Governor Speed' Setting)

CRITICAL SPEED 2 MIN (rpm) dflt= 1.0 (1.0, 20000)
 Set the lower limit of the critical speed avoidance band followed by the
 ENTER key.
(Must be less than the 'Critical Speed 2 Max' Setting)

Operating Parameters Block

When this header appears in the display, press the down arrow key to configure this block or press a left or right arrow key to select another block to configure.

GENERATOR APPLICATION? dflt= NO (Yes/No)
 Select YES followed by the ENTER key if the turbine is driving a generator.
 If YES, requires a Generator breaker and Utility Tie breaker to be
 programmed as contact inputs. If NO, skip to the 'Use Local/Remote'
 question.

USE GEN BREAKER OPEN TRIP? dflt= NO (Yes/No)
 Select YES followed by the ENTER key if opening the generator breaker is
 to initiate a turbine trip. If YES, the unit will trip when the generator breaker
 opens after being closed, unless a Controlled Stop is selected. If NO, the
 speed setpoint will instantly reset to the 'Gen Open Setpoint' which is
 defaulted to 50 rpm below rated speed.

USE TIE BREAKER OPEN TRIP? dflt= NO (Yes/No)
 Select YES followed by the ENTER key if opening the utility tie breaker is to
 initiate a turbine trip. If YES, the unit will trip when the utility tie breaker
 opens after being closed, unless a Controlled Stop is selected. If NO and
 the generator breaker is closed, the speed setpoint will instantly reset to the
 speed last seen by the unit and move to the 'Rated Speed Setpoint' and an
 alarm is issued. If NO and the generator breaker is open, there is only an
 alarm when the utility tie breaker opens.

USE KW DROOP? dflt= NO (Yes/No)
 Set to YES to use KW droop (generator load control) or NO to use internal
 Speed droop (turbine inlet valve position) followed by the ENTER key. If
 YES, generator KW feedback is used as the controlling parameter for
 stability when the unit is on-line. If NO, internal LSS demand/actuator
 position droop is used.

KW MAX LOAD (KW) dflt= 20000 (0.1, 20000)
 Enter the max load followed by the ENTER key. This setting limits the
 maximum load the turbine/generator can carry.
(Must be less than or equal to the 'KW Input at 20 mA' Setting)

DROOP (%) dflt= 5.0 (0.0, 10)
 Enter the droop percentage followed by the ENTER key. Typically set
 between 4-6% and not more than 10%.

RATED SPEED SETPOINT (rpm) dflt= 3600 (0.0, 20000)
 Set the generator's rated speed setpoint followed by the ENTER key.
*(Must be greater than or equal to the 'Minimum Governor Speed' Setting
 and less than the/Maximum Governor Speed' setting)*

USE FREQ ARM/DISARM? dflt= NO (Yes/No)
 Set to YES is using frequency control arm/disarm followed by the ENTER
 key. If YES, frequency control must be armed before the unit will switch into
 frequency control. If NO, frequency control is always armed and the unit will
 go into frequency control whenever the generator breaker is closed and the
 utility tie breaker is open.
(Cannot program both Freq Arm/Disarm and Loadsharing)

USE LOCAL/REMOTE? dflt= NO (Yes/No)
 Set to YES if using Local/Remote control logic followed by the ENTER key.
 If YES, permits the unit to go from REMOTE (Modbus, contact input and front panel) control to LOCAL (front panel) control only. If NO, all programmed inputs are active at all times. Refer to the Service Mode information in Volume 2 for additional settings on the Local/Remote function.

Driver Configuration Block

When this header appears in the display, press the down arrow key to configure this block or press a left or right arrow key to select another block to configure.

ACTUATOR 1 IS 4–20 mA ? dflt= NO (Yes/No)
 Select actuator #1 output current range. Select YES for 4–20 mA or NO for 20–160 mA followed by the ENTER key. Most Woodward actuators are 20–160 mA.

INVERT DRIVER OUTPUTS ? dflt= NO (Yes/No)
 Set to YES to invert actuator driver output(s) followed by the ENTER key. This is normally set to NO and is typically only used in certain applications where the 505 has a backup controller that takes control when the 505 fails.

USE ACT 1 FAULT SHUTDOWN ? dflt= YES (Yes/No)
 Select YES followed by ENTER to issue a trip whenever an actuator fault is detected. If YES, the 505 will issue a shutdown if Actuator 1 has a fault. If NO, an actuator fault alarm will be issued when a fault is detected. An actuator fault will be determined if the current drops below or goes above the failure levels, basically checking for an open or a short circuit in the actuator wires/coil.

ACTUATOR 1 DITHER (%) dflt= 0.0 (0.0, 10)
 Enter the dither percentage for actuator #1 followed by the ENTER key. Enter 0.0 if no dither is required. Woodward TM-type actuators typically require dither. This value can be changed in the Run Mode while the turbine is operating. See Run Mode—Chapter 5.

USE ACTUATOR NUMBER 2? dflt= NO (Yes/No)
 Select YES followed by ENTER if using both Actuator outputs (Act 1 & Act 2). If NO skip to 'Use Actuator 2 as a Readout'.

ACTUATOR 2 IS 4–20 mA ? dflt= NO (Yes/No)
 Select actuator #2 output current range. Select YES for 4–20 mA or NO for 20- 160 mA followed by the ENTER key. Most Woodward actuators are 20–160 mA.

ACTUATOR 2 OFFSET (%) dflt= 0.0 (0.0, 100)
 Enter the percentage actuator #1 is opened when actuator #2 begins to open followed by the ENTER key. Enter 0.0 if both actuators open together.

USE ACT 2 FAULT SHUTDOWN? dflt= YES (Yes/No)
 Select YES followed by ENTER to issue a trip whenever an actuator fault is detected. If YES, the 505 will issue a shutdown if Actuator 2 has a fault. If NO, an actuator fault alarm will be issued when a fault is detected. An actuator fault will be determined if the current drops below or goes above the failure levels, basically checking for an open or a short circuit in the actuator wires/coil.

ACTUATOR 2 DITHER (%) dflt= 0.0 (0.0, 10)
 Enter the dither percentage for actuator #2 followed by the ENTER key. Enter 0.0 if no dither is required. Woodward TM-type actuators typically require dither. This value can be changed in the Run Mode while the turbine is operating. See Run Mode—Chapter 5.

USE ACTUATOR 2 AS A READOUT? dflt= NO (Yes/No)

Select YES followed by ENTER to use the actuator output as an additional readout. When set to NO, the actuator #2 output is not used for anything. This option is available for customers who do not need two actuator drivers and would like an additional readout.

ACTUATOR 2 READOUT IS: (must choose from list)

Scroll through the option list by using the Adjust Up/Down Arrows or by selecting the NO key until the option desired appears, then press the YES or ENTER keys to select the option/function.

OPTIONS FOR ACTUATOR 2 READOUT

Actual Speed	Rmt Cascade Setpt
Speed Setpoint	Auxiliary Input
Remote Speed Setpt	Auxiliary Setpoint
Sync/Load Share Input	Rmt Auxiliary Setpt
KW Input	Valve Limiter Setpoint
Cascade Input	Actuator 1 Readout
Cascade Setpoint	First Stage Press Input

(The function that the readout uses must be programmed or an error message will occur. For example, to use the Cascade Setpoint readout, the 'Use Cascade' function must be programmed)

READOUT 4 mA VALUE (UNITS) dflt= 0.0 (-20000, 20000)

Set the value (in engineering units) that corresponds to 4 milliamps (mA) on the analog output followed by the ENTER key. If the value on the display is correct, just select the ENTER key which will advance you to the next question.

READOUT 20 mA VALUE (UNITS) dflt= 0.0 (-20000, 20000)

Set the value (in engineering units) that corresponds to 20 milliamps (mA) on the analog output followed by the ENTER key. If the value on the display is correct, just select the ENTER key which will advance you to the next question.

(Must be greater than the 'Readout 4 mA Value' Setting)

Analog Inputs Block

When this header appears in the display, press the down arrow key to configure this block or press a left or right arrow key to select another block to configure. No two analog inputs can be programmed for the same function. In addition, the function that the analog input uses must be programmed or an error message will occur. For example, to use the Cascade Input, the 'Use Cascade' function must be programmed.

The first five (1-5) analog inputs are differential inputs that can be from a self-powered or a loop-powered (24 Vdc from 505) transducer. However, analog input #6 is an isolated analog input and should be used when isolation is required (refer to Chapter 2 for information on the analog input hardware).

ANALOG INPUT # 1 FUNCTION (must choose from list)

Scroll through the option list by using the Adjust Up/Down Arrows or by selecting the NO key until the option desired appears, then press the YES or ENTER keys to select the option/function.

ANALOG INPUT OPTIONS

Remote Speed Setpt	Remote Cascade Setpt
Synchronizing Input	Auxiliary Input
Sync/Load Share Input	Remote Aux Setpt
KW/Unit Load Input	First Stage Press Input
Cascade Input	(Not Used)

- INPUT 1—4 mA VALUE (UNITS) dflt= 0.0 (-20000, 20000)
 Set the value (in engineering units) that corresponds to 4 milliamps (mA) on the analog input followed by the ENTER key. If the value on the display is correct, just select the ENTER key which will advance you to the next question.
- INPUT 1—20 mA VALUE (UNITS) dflt= 100 (-20000, 20000)
 Set the value (in engineering units) that corresponds to 20 milliamps (mA) on the analog input followed by the ENTER key. If the value on the display is correct, just select the ENTER key which will advance you to the next question.
(Must be greater than the 'Input 4 mA Value' Setting)

Analog Inputs # 2 through # 6 are entered following the same rules as described for Analog Input # 1.

Contact Inputs Block

When this header appears in the display, press the down arrow key to configure this block or press a left or right arrow key to select another block to configure.

If unit is configured as a 'Generator Set', then contact inputs must be programmed for generator and tie breaker contacts. Also, each contact input option may be configured only once. In addition, the function that the contact input uses must be programmed or an error message will occur. For example, to use the Cascade Control Enable contact input, the 'Use Cascade' function must be programmed.

- CONTACT INPUT 1 FUNCTION (must choose from list)
 Scroll through the option list by using the Adjust Up/Down Arrows or by selecting the NO key until the option desired appears, then press the YES or ENTER keys to select the option/function.

CONTACT INPUT OPTIONS

(Not Used)	Casc Setpt Raise
Generator Breaker	Casc Setpt Lower
Utility Tie Breaker	Casc Control Enable
Overspeed Test	Remote Casc Setpt Enable
External Run	Aux Setpt Raise
Start Permissive	Aux Setpt Lower
Idle/Rated	Aux Control Enable
Halt/Continue Auto Start Sequence	Remote Aux Setpt Enable
Override MPU Fault	Valve Limiter Open
Select On-Line Dynamics	Valve Limiter Close
Local/Remote	External Trip 2
Remote Speed Setpt Enable	External Trip 3
Sync Enable	External Trip 4
Controlled Shutdown (Manual)	External Trip 5
Freq Control Arm/Disarm	

Contact Inputs # 2 through # 12 are entered following the same rules as described for Contact Input # 1.

Function Keys Block

When this header appears in the display, press the down arrow key to configure this block or press a left or right arrow key to select another block to configure. Each function key option may be configured only once. In addition, the function that the function key uses must be programmed or an error message will occur. For example, to use the Cascade Control Enable function key, the 'Use Cascade' function must be programmed.

F3 KEY PERFORMS (must choose from list)

Scroll through the option list by using the Adjust Up/Down Arrows or by selecting the NO key until the option desired appears, then press the YES or ENTER keys to select the option/function.

OPTIONS FOR FUNCTION KEYS F3 & F4

(Not Used)	Freq Arm/Disarm
Local/Remote	Casc Control Enable
Idle/Rated	Remote Casc Setpt Enable
Halt/Continue Auto Start Sequence	Aux Control Enable
Remote Speed Setpt Enable	Remote Aux Setpt Enable
Sync Enable	Energize Relay Output

BLINK F3 LED WHEN NOT ACTIVE? dflt= NO (Yes/No)

Select YES followed by ENTER to blink the function key's LED when the function is not active but is enabled. The LED will be ON whenever the function is active. If NO, the function key LED is ON when the function is enabled, active, or in control.

F4 KEY PERFORMS (must choose from list)

Scroll through the option list by using the Adjust Up/Down Arrows or by selecting the NO key until the option desired appears, then press the YES or ENTER keys to select the option/function.

BLINK F4 LED WHEN NOT IN CNTRL? dflt= NO (Yes/No)

Select YES followed by ENTER to blink the function key's LED when the function is not active but is enabled. The LED will be ON whenever the function is active or in control. If NO, the function key LED is ON when the function is enabled, active, or in control.

Auxiliary Control Block

When this header appears in the display, press the down arrow key to configure this block or press a left or right arrow key to select another block to configure.

USE AUXILIARY CONTROL? dflt= NO (Yes/No)

Select YES followed by ENTER to configure the auxiliary control function. Select NO if the auxiliary function is not used.

LOST AUX INPUT SHUTDOWN? dflt= NO (Yes/No)

Select YES followed by ENTER if a shutdown command is to be given when the auxiliary input fails. If NO, then no shutdown command will be given when the auxiliary input fails, only an alarm.

USE KW INPUT? dflt= NO (Yes/No)

If YES, allows the AUX control channel to use the KW Input programmed. When YES, no AUX analog input is needed. When NO, an AUX analog input must be programmed.

INVERT AUX INPUT? dflt= NO (Yes/No)

Select YES followed by ENTER if the auxiliary control will be reverse acting. If NO, then the control will be forward acting. Typically this will be set to NO, the only time the input would be inverted is if the valve needs to open when the input exceeds the setpoint. An example where the invert would be YES is for turbine inlet pressure control.

- MIN AUX SETPOINT (UNITS) dflt= 0.0 (-20000, 20000)
Set the min AUX setpoint followed by ENTER. This value is the minimum setpoint value that the auxiliary setpoint can be decreased/lowered to (lower limit of AUX setpoint).
- MAX AUX SETPOINT (UNITS) dflt= 100 (-20000, 20000)
Set the max AUX setpoint followed by ENTER. This value is the maximum setpoint value that the auxiliary setpoint can be increased/raised to (upper limit of AUX setpoint).
(Must be greater than the 'Min Aux Setpt' Setting)
- AUX SETPOINT RATE (UNITS/sec) dflt= 5.0 (0.01, 1000)
Set the AUX setpoint rate followed by ENTER. This value is the rate (in units per second) at which AUX setpoint moves when adjusted.
- USE AUX ENABLE? dflt= NO (Yes/No)
Select YES followed by ENTER if using the Auxiliary control enable/disable feature. If YES, Aux will require an ENABLE command to enable Aux control. If NO, then the Auxiliary function will be enabled constantly and will act as a controlling limiter. An example of using Aux as a limiter is using Aux to limit the maximum KW load that the unit carries. The Aux PID is not normally in control of the valve output. But if the Aux (KW) input exceeds the setpoint, the Aux PID controller would decrease and take control of the valve until the KW level decreases below the maximum kW(Aux) setting. Alternatively, if the Aux enable is used, the Aux setpoint tracks the Aux input. When enabled, the Aux PID takes control of the valve and the speed setpoint tracks the speed/load of the unit for bumpless transfer between modes.
- SETPT INITIAL VALUE (UNITS) dflt= 0.0 (-20000, 20000)
Set the setpoint initialization value followed by ENTER. When not using the Aux Enable function, this is the value that the auxiliary setpoint initializes to upon power- up or exiting the program mode.
(Must be less than or equal to the 'Max Aux Setpoint' Setting)
- AUX DROOP (%) dflt= 0.0 (0.0, 100)
Enter the droop percentage followed by the ENTER key. If required, typically set between 4-6%.
- AUX PID PROPORTIONAL GAIN (%) dflt= 1.0 (0.0, 100)
Enter the AUX PID proportional gain value followed by ENTER. This value is used to set auxiliary control response. This value can be changed in the Run Mode while the turbine is operating. If unknown, a recommended starting value is 1%.
- AUX PID INTEGRAL GAIN (%) dflt= 0.3 (0.001, 50)
Enter the AUX PID integral gain value followed by ENTER. This value is used to set auxiliary control response. This value can be changed in the Run Mode while the turbine is operating. If unknown, a recommended starting value is 3%.
- AUX PID DERIVATIVE RATIO (%) dflt= 100 (0.01, 100)
Enter the AUX PID derivative ratio followed by ENTER. This value is used to set auxiliary control response. This value can be changed in the Service Mode while the turbine is operating. If unknown, a recommended starting value is 100%.
- TIEBRKR OPEN AUX DSBL ? dflt= YES (Yes/No)
Select YES followed by ENTER if the auxiliary control will be disabled when the utility tie breaker opens. If NO is selected, then auxiliary control will not be disabled when the utility tie breaker is opened.
- GENBRKR OPEN AUX DSBL ? dflt= YES (Yes/No)
Select YES followed by ENTER if the auxiliary control will be disabled when the generator breaker opens. If NO is selected, then auxiliary control will not be disabled when the generator breaker is opened.
- USE REMOTE AUX SETTING ? dflt= NO (Yes/No)
Set to YES to allow the aux setpoint to be adjusted from an analog input.
(Must program a 'remote auxiliary setpoint' analog input)

REMOTE AUX MAX RATE (UNITS/sec) dflt= 5.0 (0.1, 1000)
 Enter the maximum rate at which the remote input will move the aux setpoint followed by the ENTER key.

AUXILIARY UNITS OF MEASURE: (must choose from list)
 Scroll through the option list by using the Adjust Up/Down Arrows or by selecting the NO key until the option desired appears, then press the YES or ENTER keys to select the option/function.

Options:

psi	t/h
kPa	k#/hr
MW	#/hr
KW	kg/cm2
degF	bar
degC	atm
(none)	

Cascade Control Block

When this header appears in the display, press the down arrow key to configure this block or press a left or right arrow key to select another block to configure.

USE CASCADE CONTROL? dflt= NO (Yes/No)
 Select YES followed by ENTER to configure the cascade control function.
 Select NO if the cascade function is not used.

INVERT CASCADE INPUT? dflt= NO (Yes/No)
 Select YES followed by ENTER if the cascade control will be reverse acting. If NO is selected, the control will be forward acting. Typically this will be set to NO, the only time the input would be inverted is if the valve needs to open when the input exceeds the setpoint. An example where the invert would be YES is for turbine inlet pressure control.

MIN CASCADE SETPOINT (UNITS) dflt= 0.0 (-20000, 20000)
 Set the minimum cascade setpoint followed by ENTER. This value is the minimum setpoint value that the cascade setpoint can be decreased/lowered to (lower limit of cascade setpoint).

MAX CASCADE SETPOINT (UNITS) dflt= 100 (-20000, 20000)
 Set the maximum cascade setpoint followed by ENTER. This value is the maximum setpoint value that the cascade setpoint can be increased/raised to (upper limit of cascade setpoint).
(Must be greater than the 'Min Cascade Setpt' Setting)

CASC SETPT RATE (UNITS/sec) dflt= 5.0 (0.01, 1000)
 Set the cascade setpoint rate followed by ENTER. This value is the rate (in units per second) at which cascade setpoint moves when adjusted.

USE SETPOINT TRACKING? dflt= NO (Yes/No)
 Select YES or NO followed by ENTER. If YES, the cascade setpoint tracks the cascade input to provide bumpless transfer to cascade control when it is enabled. If NO, the cascade setpoint remains at the last position except on power-up or exiting the program mode.

SETPT INITIAL VALUE (UNITS) dflt= 100.0 (-20000, 20000)
 Set the setpoint initialization value followed by ENTER. When not using the Setpoint Tracking function, this is the value that the cascade setpoint initializes to upon power-up or exiting the program mode.
(Must be less than or equal to the 'Max Cascade Setpt' Setting)

SPEED SETPOINT LOWER LIMIT (rpm) dflt= 3605 (0.0, 20000)
 Set the minimum speed setpoint that the cascade controller can lower the speed setpoint to followed by ENTER. To protect the unit, this value should be at or above rated speed if the unit is a generator.
(Must be greater than or equal to the 'Minimum Governor Speed Setpt' Setting)

- SPEED SETPOINT UPPER LIMIT (rpm) dflt= 3780 (0.0, 20000)
 Set the maximum speed setpoint that cascade controller can raise the speed setpoint to followed by the ENTER key.
(Must be less than or equal to the 'Maximum Governor Speed Setpt' Setting)
- MAX SPEED SETPOINT RATE (rpm/sec) dflt= 20 (0.1, 100)
 Set the maximum rate at which the cascade control can vary the speed setpoint followed by the ENTER key.
- CASCADE DROOP (%) dflt= 0.0 (0.0, 100)
 Enter the droop percentage followed by the ENTER key. If needed, typically set between 4-6%.
- CASCADE PID PROPORTIONAL GAIN (%) dflt= 5.0 (0.0, 100)
 Enter the cascade PID proportional gain value followed by ENTER. This value is used to set cascade control response. This value can be changed in the Run Mode while the turbine is operating. If unknown, a recommended starting value is 5%.
- CASCADE PID INTEGRAL GAIN (%) dflt= 0.3 (0.001, 50.0)
 Enter the cascade PID integral gain value followed by ENTER. This value is used to set cascade control response. This value can be changed in the Run Mode while the turbine is operating. If unknown, a recommended starting value is 0.3%.
- CASCADE PID DERIVATIVE RATIO (%) dflt= 100 (0.01, 100)
 Enter the cascade PID derivative ratio followed by ENTER. This value is used to set cascade control response. This value can be changed in the Service Mode while the turbine is operating. If unknown, a recommended starting value is 100%.
- USE REMOTE CASCADE SETTING? dflt= NO (Yes/No)
 Set to YES to allow the Cascade setpoint to be adjusted from an analog input.
(Must program a 'remote cascade setpoint' analog input)
- RMT CASCADE MAX RATE (UNITS/sec) dflt= 5.0 (0.1, 1000)
 Enter the maximum rate at which the remote input will move the cascade setpoint followed by the ENTER key.
- CASCADE UNITS OF MEASURE: (must choose from list)
 Scroll through the option list by using the Adjust Up/Down Arrows or by selecting the NO key until the option desired appears, then press the YES or ENTER keys to select the option/function.
 Options:
 psi kPa
 MW KW
 degF degC
 t/h k#/hr
 kg/cm² bar
 atm #/hr
 (none)

Readouts

When this header appears in the display, press the down arrow key to configure this block or press a left or right arrow key to select another block to configure. All six 4–20 mA analog readouts may be configured. The function that the readout uses must be programmed or an error message will occur. For example, to use the Cascade Setpoint readout, the 'Use Cascade' function must be programmed.

ANALOG READOUT # 1 FUNCTION (must choose from list)

Scroll through the option list by using the Adjust Up/Down Arrows or by selecting the NO key until the option desired appears, then press the YES or ENTER keys to select the option/function.

ANALOG READOUT OPTIONS

Actual Speed	Auxiliary Input
Speed Setpoint	Auxiliary Setpoint
Remote Speed Setpt	Rmt Auxiliary Setpt
Load Share Input	Valve Limiter Setpoint
Sync Input	Actuator Demand Readout
KW Input	Actuator 1 Readout
Cascade Input	Actuator 2 Readout
Cascade Setpoint	First Stg Press Input
Rmt Cascade Setpt	(Not Used)

READOUT 1—4 mA VALUE (UNITS) dflt= 0.0 (-20000, 20000)

Set the value (in engineering units) that corresponds to 4 milliamps (mA) on the analog output followed by the ENTER key. If the value on the display is correct, just select the ENTER key which will advance you to the next question.

READOUT 1—20 mA VALUE (UNITS) dflt= 100 (-20000, 20000)

Set the value (in engineering units) that corresponds to 20 milliamps (mA) on the analog output followed by the ENTER key. If the value on the display is correct, just select the ENTER key which will advance you to the next question.

(Must be greater than the 'Readout 4 mA Value' Setting)

Readouts # 2 through # 6 are entered following the same rules as described for Readout # 1.

Relays Block

When this header appears in the display, press the down arrow key to configure this block or press a left or right arrow key to select another block to configure.

You may configure up to six relays in addition to the two pre-assigned relays (Alarm, Shutdown). The relay can be configured as either a level switch or as an indication. An example of a level switch is a Speed Switch and an example of an indication is Cascade Control Enabled.

USE RELAY # 1? dflt= NO (Yes/No)

Press Set to YES followed by ENTER to use this relay output. Press NO followed by ENTER to skip to the next 'USE RELAY' question.

IS RELAY # 1 A LEVEL SWITCH? dflt= NO (Yes/No)

Press YES followed by ENTER to use this relay output as a level switch. Press NO followed by ENTER to skip to the 'RELAY ENERGIZES ON:' question..

RELAY 1 IS LEVEL SWITCH FOR : (must choose from list)

Scroll through the option list by using the Adjust Up/Down Arrows or by selecting the NO key until the option desired appears, then press the YES or ENTER keys to select the option/function.

LIST OF OPTIONS FOR LEVEL SWITCH

Actual Speed Level	Aux Setpoint Level
Speed Setpoint Level	Valve Limiter Level
KW Input Level	Actuator Demand (hand valve)
Sync/Load Share Level	Act 1 Output Level
Cascade Input Level	Act 2 Output Level
Cascade Setpoint Level	First Stg Press Level
Aux Input Level Switch	

- RELAY 1 ON LEVEL (UNITS) dflt= 0.0 (-20000, 20000)
 Enter the level switch ON setting in engineering units followed by the ENTER key. There is an ON and an OFF setting for each level switch option. This allows the user to program the desired hysteresis for the function selected.
- RELAY 1 OFF LEVEL (UNITS) dflt= 0.0 (-20000, 20000)
 Enter the level switch OFF setting in engineering units followed by the ENTER key.
(Must be less than the 'Relay On Level' Setting)
- RELAY 1 ENERGIZES ON : (must choose from list)
 Scroll through the option list by using the Adjust Up/Down Arrows or by selecting the NO key until the option desired appears, then press the YES or ENTER keys to select the option/function.
- OPTIONS FOR RELAYS IF USED TO INDICATE STATE
- | | |
|--------------------------------------|---------------------------|
| Shutdown Condition | Sync Enabled |
| Trip Relay (add'l trip relay output) | Sync/Load Share Active |
| Alarm Condition | Load Share Control |
| 505 Control OK | Casc Control Enabled |
| Overspeed Trip | Cascade Control Active |
| Overspeed Test Enabled | Remote Casc Setpt Enabled |
| Speed PID in Control | Remote Casc Setpt Active |
| Remote Speed Setpt Enabled | Aux Control Enabled |
| Remote Speed Setpt Active | Aux Control Active |
| Underspeed Switch | Auxiliary PID in Control |
| Auto Start Sequence Halted | Remote Aux Setpt Enabled |
| On-Line PID Dynamics Mode | Remote Aux Setpt Active |
| Local Control Mode | Valve Limiter in Control |
| Frequency Control Armed | F3 Key Selected |
| Frequency Control | F4 Key Selected |
| Modbus Command Selected | |

Relay outputs # 2 through # 6 are entered following the same rules as described for Relay output # 1.

Communications Block

When this header appears in the display, press the down arrow key to configure this block or press a left or right arrow key to select another block to configure.

- USE COMMUNICATIONS? dflt= NO (Yes/No)
 Set to YES followed by ENTER to use the Modbus communications feature of the 505. There are two identical Modbus ports available. Either or both can be configured for use. Select NO followed by ENTER if Modbus communications will not be used.
- USE MODBUS PORT 1? dflt= NO (Yes/No)
 Set to YES followed by ENTER to use the Modbus Port 1. Set to NO followed by ENTER to skip to 'Use Modbus Port 2'. If the displayed value is already correct, simply select ENTER.
- MODE: ASCII OR RTU dflt= 2 (1, 2)
 Enter the integer corresponding to the Modbus transmission mode required followed by the ENTER key. Enter a '1' for ASCII mode or a '2' for RTU mode. For more information on the difference between these modes, refer to Chapter 6. If the displayed value is already correct, simply select ENTER.
- MODBUS DEVICE NUMBER dflt= 1 (1, 247)
 Enter the integer corresponding to the Modbus device number/address required followed by the ENTER key. If the displayed value is already correct, simply select ENTER.

- COMMUNICATIONS MODE** dfit= 1 (1, 3)
 Enter the integer corresponding to the serial communications mode required followed by the ENTER key. Enter a '1' for RS-232, a '2' for RS-422 or a '3' for RS-485 communications. If the displayed value is already correct, simply select ENTER.
- PORT1 BAUD RATE** dfit= 9 (1, 11)
 Enter the integer corresponding to the communications baud rate followed by the ENTER key. If the displayed value is already correct, simply select ENTER.
 1 = 110 2 = 300 3 = 600 4 = 1200
 5 = 1800 6 = 2400 7 = 4800 8 = 9600
 9 = 19200 10 = 38400 11 = 57600
- PORT 1 STOP BITS** dfit= 1 (1, 3)
 Enter the integer corresponding to the stop bits required followed by the ENTER key. If the displayed value is already correct, simply select ENTER. Enter a '1' for 1 stop bit, a '2' for 1.5 stop bits or a '3' for 2 stop bits.
- PORT 1 PARITY** dfit= 1 (1, 3)
 Enter the integer corresponding to the parity required followed by the ENTER key. If the displayed value is already correct, simply select ENTER. Enter a '1' for none, a '2' for odd parity or a '3' for even parity.
- USE MODBUS PORT 2?** dfit= NO (Yes/No)
 Set to YES followed by ENTER to use the Modbus Port 2. If the displayed value is already correct, simply select ENTER. Modbus Port # 2 is entered following the same rules as described for Modbus Port # 1.

Exiting the Program Mode

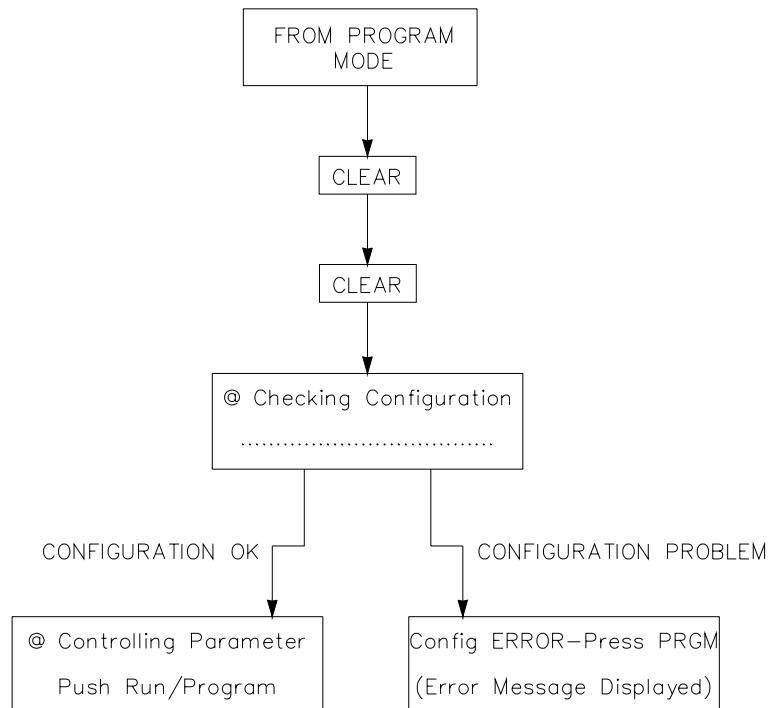

850-117
 96-03-07 KDW

Figure 4-4. Exiting the Program Mode

Once the programming steps have been completed, the Program Mode can be exited (refer to Figure 4-4 Exiting the Program Mode). To exit the Program mode the "CLEAR" key is pressed twice. This initiates the 505 to save the configuration and to begin a Configuration Check procedure. If there are no errors in the programming, the 505 front-panel will return to the ready state and display the 'Controlling Parameter/Press Run or Program' screen. However, if there is an error in the program, the 'Config ERROR—Press PRGM' display will appear along with the programming error(s) discovered. The next section identifies the various configuration error messages and explains the meaning of the error.

Program Configuration Error Messages

When the Program Mode is exited, the control automatically performs a completeness check on the configured program to assure that required program blocks have values loaded into them. This check cannot determine if the values entered are realistic, but it makes sure that values have been loaded into required parameters. If any errors are found in the program, the 'Config ERROR—Press PRGM' display will appear along with the programming error(s) discovered. If there is more than one error discovered, they can be displayed by pressing the down arrow key. This key will scroll through all the error messages and allow you to determine their cause(s).

The configuration error message alerts you that a programming change is required before the configured program can operate the turbine. You must re-enter the Program Mode and fix the problem before the control will allow the turbine to run. The completeness check will continue to fail until the control is satisfied that the configured program is complete.

This section of the manual identifies the various configuration error messages that may appear and explains the meaning of the error.

Start/Speed Program Errors

No Start Mode Selected—RUN was selected but no start mode was selected in the Program mode. One of the three start modes must be selected in the Program mode under the Start Block.

Speed > 15000 Hz—The maximum speed input is 15000 hertz. This is a limitation of the 505's hardware/speed sensing circuitry. The frequency input of the speed sensor must be less than this value. The gear the speed sensor is mounted on may need to be changed to one with less teeth, this will decrease the frequency seen by the speed probes.

Spd #1 Fld < Freq Range—The failed speed setting for speed input #1 is below the minimum allowed setting. The minimum allowed setting is calculated as follows: $(\text{Overspeed Test Limit}) * (0.0204)$.

Spd #2 Fld < Freq Range—The failed speed setting for speed input #2 is below the minimum allowed setting. The minimum allowed setting is calculated as follows: $(\text{Overspeed Test Limit}) * (0.0204)$.

Critical Speed Program Errors

Crit Rate < Slow Rate—The acceleration rate (rpm/second) through the critical speed avoidance band must be faster than the normal speed setpoint rate.

Crit Spd Err/No Idle—A critical speed avoidance band was programmed but neither idle/rated or auto start sequence was programmed. To use the critical speed avoidance logic one of these functions that uses an idle speed must be programmed.

Lo Idle set in Critical—Either the idle speed setpoint (when using idle/rated) or the low idle setpoint (when using the auto start sequence) was programmed within a critical speed avoidance band.

Hi Idle set in Critical—The hi idle speed setpoint (when using the auto start sequence) was programmed within a critical speed avoidance band.

Idle Program Errors

Idle Setpt > Min Gov—The Idle Speed setpoint was programmed at a higher speed than the minimum governor speed setpoint.

Rated Speed > Max Gov—The Rated Speed setpoint was programmed at a higher speed than the maximum governor speed setpoint.

Generator Program Errors

KW Max Load > KW Input—The KW Max Load setting was programmed at a higher value than the maximum KW input (KW input at 20 mA).

No Utility Brkr Config—The unit is programmed for a generator application but no utility tie breaker contact input was programmed. This is a requirement.

No Gen Brkr Config—The unit is programmed for a generator application but no utility tie breaker contact input was programmed. This is a requirement.

No Freq Arm/Dsarm Prgmd—The frequency arm/disarm function was programmed but no means of arming or disarming were programmed. Either a function key or a contact input must be programmed to arm/disarm frequency control if you wish to use the frequency arm/disarm function.

Sync & Sync/Ld Shr Pgmd—Both the synchronizing analog input and the sync/load share or load share analog inputs were programmed. If the application needs to perform both synchronizing and load sharing with analog signals, only the sync/load sharing analog input needs to be programmed.

Freq Arm & Ld Shr Pgmd—Both the frequency arm/disarm function and the load share control functions were programmed. Only one of these modes can be programmed — either freq arm/disarm OR Load Sharing.

Contact Input Program Errors

Two Identical Contacts—Two contact inputs were programmed for the same function.

Contact #xx Program Err—The specified contact input was programmed for a function that is not also programmed to be used. Either the contact input was mis-programmed or the function required is mis-programmed. For example, contact input #1 is programmed for Remote Cascade Setpoint Enable but Remote Cascade Setpoint was not programmed under the Cascade Program Block.

Analog Input Program Errors

Two Identical Analogs—Two analog inputs were programmed for the same function.

Analog #x Program Err—The specified analog input was programmed for a function that is not also programmed to be used. Either the analog input was mis-programmed or the function required is mis-programmed. For example, analog input #1 is programmed for Remote Cascade Setpoint but Remote Cascade Setpoint was not programmed under the Cascade Program Block.

No Rmt Speed Input Prgm—The remote speed setpoint control function was programmed but no remote speed setpoint analog input was configured.

No KW Analog Input—Either the auxiliary control function was programmed to use the KW input or KW droop was programmed but no KW analog input was configured.

No Sync Analog Input—A synchronizing contact input was programmed but no synchronizing analog input was configured.

No Ld Share Analog In—A load share or sync/load share contact input was programmed but no load share analog input was configured.

No Cascade Analog Input—The cascade control function was programmed but no cascade analog input was configured.

No Rmt Casc Input Prgm—The remote cascade setpoint control function was programmed but no remote cascade setpoint analog input was configured.

No Aux Analog Input—The auxiliary control function was programmed but no auxiliary analog input was configured.

KW & Aux Config for Aux—The auxiliary control function was programmed to use the KW analog input but an auxiliary analog input was configured also. With this configuration, only the KW analog input is used for the auxiliary controller.

No Rmt Aux Input Prgm—The remote auxiliary setpoint control function was programmed but no remote auxiliary setpoint analog input was configured.

Function Key Program Errors

Identical Function Keys—Both function keys were programmed for the same function.

No F-Key Relay Prgmd—A function key was programmed to energize a relay but no relay outputs were configured for F3 or F4 key relays.

F3 Key Program Error—The F3 key was programmed for a function that is not also programmed to be used. Either F3 was mis-programmed or the function required was mis-programmed. For example, the F3 key is programmed for Remote Cascade Setpoint Enabled but Remote Cascade Setpoint was not programmed under the Cascade Program Block.

F4 Key Program Error—The F4 key was programmed for a function that is not also programmed to be used. Either F4 was mis-programmed or the function required was mis-programmed. For example, the F4 key is programmed for Remote Cascade Setpoint Enabled but Remote Cascade Setpoint was not programmed under the Cascade Program Block.

Relay Program Errors

Relay #x Program Error—The specified relay was programmed for a function that is not also programmed to be used. Either the relay was mis-programmed or the function required is mis-programmed. For example, relay #1 is programmed for Remote Cascade Setpoint Enabled but Remote Cascade Setpoint was not programmed under the Cascade Program Block.

Readout Program Errors

Readout #x Program Err—The specified readout was programmed for a function that is not also programmed to be used. Either the readout was mis-programmed or the function required is mis-programmed. For example, readout #1 is programmed for Cascade Setpoint but Cascade Control was not programmed under the Cascade Program Block.

Driver 2 Readout Err—The Actuator/Driver 2 readout was programmed for a function that is not also programmed to be used. Either the readout was mis-programmed or the function required is mis-programmed. For example, driver 2 is programmed for Cascade Setpoint but Cascade Control was not programmed under the Cascade Program Block.

Valve/Actuator Calibration & Test

Before initial operation or after a turbine overhaul where any actuator or valve travel may have been affected, the below Valve Calibration procedure should be followed to insure that the 505 is correctly calibrated to the turbine control valve(s). When calibration is complete, 0 to 100% actuator position as displayed by the 505 must equal 0 to 100% actual valve travel.

After a valid program has been entered the actuator and valve minimum and maximum positions can be adjusted and tested, if needed. Actuator and valve positions are determined by the drive current to the actuator. The maximum actuator current can not be adjusted lower than the minimum actuator current (see table 4-1 below). The minimum actuator current can not be adjusted higher than the maximum actuator current. The driver current ranges are determined by the setting in the Program Mode under the Driver Configuration Block.

When adjusting or testing actuator and valve travel, verify that sufficient valve overtravel at the minimum stop is achieved (1%). This assures that each valve can fully close to completely shut off the steam flow to the turbine.

Driver Limits	20–160 mA Range	4–20 mA Range
Overcurrent	217 mA	26 mA
Undercurrent	5 mA	0.6 mA
Max Output Current Range	10-200 mA	2-24 mA
Max Output Impedance	45 Ω	360 Ω
Min Stop Adjust Range	10-80 mA	2-20 mA
Max Stop Adjust Range	100-200 mA	10-24 mA

Table 4-1. Actuator Driver Limits

To ensure proper control to actuator resolution do not calibrate the span of the actuator output to less than a range of 100 mA (20–160 mA output) or 12 mA (4-20 mA output). If necessary, the actuator to valve linkage may need to be adjusted to ensure proper 505 to valve resolution.

Figures 4-5 and 4-6 graphically show the steps available to stroke the actuator output(s). The stroking option is only available when the 505 control is in a shutdown state. Also, the screens displayed varies with the number of actuators programmed.

After enabling the stroke mode, there are options available to adjust the minimum and maximum stops and to manually stroke the output(s). The manual adjustment mode can be used to stroke the actuator and valves from 0 to 100% after the minimum and maximum positions have been adjusted. This allows both the actuator and valve to be tested for binding, play, resolution, linearity, and repeatability. The actuator and valve positions can be varied by using the ADJ UP and DOWN keys or keying in the position desired and pressing the ENTER key. When the ENTER key is pressed, the actuator output will step to the entered position.

Press any available Run Mode key to exit the STROKE ACTUATORS mode. For example, pressing the SPEED key will disable the stroking function and display the 'speed' information. To return to the STROKE ACTUATORS mode, the ACT key must be selected again and the keystrokes to enter this mode must be repeated. As a safety precaution, if the turbine speed ever exceeds 1000 rpm, the STROKE ACTUATORS mode is disabled.

As a safety precaution, if turbine speed ever exceeds 1000 rpm, the STROKE ACTUATORS mode will be automatically disabled, and actuator currents taken to zero.

Calibration/Stroking Procedure

(for single actuator output configuration)



WARNING

Before calibrating or testing, the unit must be tripped and the steam supply removed. This is to ensure that opening the control valve(s) will not allow steam into the turbine. Overspeed sensing and its relay are disabled during this process. Overspeeding the turbine may cause damage to turbine and can cause severe injury or death to personnel. **STEAM TO THE TURBINE MUST BE SHUT OFF BY OTHER MEANS DURING THIS PROCESS.**

1. The 505's Emergency shutdown contact input must be closed or jumpered throughout this procedure (or the 505's actuator current output will go to ZERO current).
2. Execute a system RESET command (Press the 505 "Reset" key).
3. Press the 505's front panel "Emergency Shutdown" button.
4. Press the 'ACT' key then the SCROLL DOWN key until the "Stroke Actuators—Dsbld, Steam Must be Off" message appears. (Verify that the turbine's steam supply has been shutoff before by an external Trip and Throttle valve.)
5. Press the "YES" key (This will cause the screen to display a "Stroke to Min—Enabled, Min Curr Adjust * 20.000" message).
6. Press the "YES" key to enable this mode or the "Scroll Down Arrow" to step to the mode desired. (Refer to Figure 4-5).
 - 6a. **Stroke to Min—Enabl, Min Curr Adjust * XXX.XX**—Press YES to force the actuator output to the minimum stop. The message will display 'At Min' and the actuator output current will move to its minimum setting. The minimum current value can be adjusted only when the 'at sign' (@) is on the bottom line of the display. Press the SELECT key to move the @ symbol between the top and bottom lines. Press the ADJ UP or DOWN keys to change the 0% actuator current level. Press the SCROLL DOWN ARROW to step the next desired mode, or the "CLEAR" key twice to save changes, and exit Calibration mode.
 - 6b. **Stroke to Max—Enabl, Max Curr Adjust * XXX.XX**—Press YES to force the actuator output to the maximum stop. The message will display 'At Max' and the actuator output current will move to its maximum setting. The maximum current value can be adjusted only when the 'at sign' (@) is on the bottom line of the display. Press the SELECT key to move the @ symbol between the top and bottom lines. Press the ADJ UP or DOWN keys to change the 100% actuator current. Press the SCROLL DOWN ARROW to step the next desired mode, or the "CLEAR" key twice to save changes and exit Calibration mode.
 - 6c. **Manually Adjust—Enabl, Stroke Valve XXX.XX**—Press the ADJ UP, ADJ DOWN keys from this screen to move the valve's output current between 0-100% at a 5%/second rate. This allows both the actuator and valve to be tested for binding, play, resolution, linearity, and repeatability.

Press the "YES" key at any time to allow a setting to be directly 'Entered'. The message will display 'Manual' when the ENTER mode is allowed. When in the 'Manual' mode, press the "ENTER" key, enter the setting desired, then press the "ENTER" key again. This will step the actuator output to a specific position instantly. Press the "ADJ UP/DOWN" or "No" keys at any time to switch back to the "Enabl" mode.

When calibration is complete, 0 to 100% valve position as displayed by the 505 must equal 0 to 100% actual valve travel. Press the SCROLL DOWN ARROW to step the next desired mode, or the "CLEAR" key twice to save changes and exit Calibration mode.

7. **Press the CLEAR key twice to permanently save any minimum or maximum actuator settings into the 505. If variables are tuned or changed but not stored in EEPROM by pressing the CLEAR key twice, then those changes will be lost if power is removed from the control or if the control receives a CPU reset.**

Calibration/Stroking Procedure

(for dual actuator output configuration)



WARNING

Before calibrating or testing, the unit must be tripped and the steam supply removed. This is to ensure that opening the control valve(s) will not allow steam into the turbine. Overspeed sensing and its relay are disabled during this process. Overspeeding the turbine may cause damage to turbine and can cause severe injury or death to personnel. **STEAM TO THE TURBINE MUST BE SHUT OFF BY OTHER MEANS DURING THIS PROCESS.**

1. The 505's Emergency shutdown contact input must be closed or jumpered throughout this procedure (or the 505's actuator current output will go to ZERO current).
2. Execute a system RESET command (Press the 505 "Reset" key).
3. Press the 505's front panel "Emergency Shutdown" button.
4. Press the ACT key then the SCROLL DOWN key until the "Stroke Actuators—Dsbld, Steam Must be Off" message appears. (Verify that the turbine's steam supply has been shutoff before by an external Trip and Throttle valve.)
5. Press the "YES" key (This will cause the screen to display a "Act #1 to Min—Enabld, Min Curr Adjust * 20.000" message).
6. Press the "YES" key to enable this mode or the "Scroll Down Arrow" to step to the mode desired. (Refer to Figure 4-6).
 - 6a. **Act #1 to Min—Enabld, Min Curr Adjust * XXX.XX**—Press YES to force the actuator output to the minimum stop. The message will display 'At Min' and the actuator output current will move to its minimum setting. The minimum current value can be adjusted only when the 'at sign' (@) is on the bottom line of the display. Press the SELECT key to move the @ symbol between the top and bottom lines. Press the ADJ UP or DOWN keys to change the 0% actuator current level. Press the SCROLL DOWN ARROW to step the next desired mode, or the "CLEAR" key twice to save changes, and exit Calibration mode.
 - 6b. **Act #1 to Max—Enabld, Max Curr Adjust * XXX.XX**—Press YES to force the actuator output to the maximum stop. The message will display 'At Max' and the actuator output current will move to its maximum setting. The maximum current value can be adjusted only when the 'at sign' (@) is on the bottom line of the display. Press the SELECT key to move the @ symbol between the top and bottom lines. Press the ADJ UP or DOWN keys to change the 100% actuator current level. Press the SCROLL DOWN ARROW to step the next desired mode, or the "CLEAR" key twice to save changes and exit Calibration mode.
 - 6c. **Manually Adjust—Enabld, Stroke Valve XXX.XX**—Press the ADJ UP, ADJ DOWN keys from this screen to move the valve's output current between 0-100% at a 5%/second rate. This allows both the actuator and valve to be tested for binding, play, resolution, linearity, and repeatability.

Press the "YES" key at any time to allow a setting to be directly Entered. The message will display 'Manual' when the ENTER mode is allowed. When in the 'Manual' mode, press the "ENTER" key, enter the setting desired, then press the "ENTER" key again. This will step the actuator output to a specific position instantly. Press the "ADJ UP/DOWN" or "No" keys at any time to switch back to the "Enabld" mode.

When calibration is complete, 0 to 100% valve position as displayed by the 505 must equal 0 to 100% actual valve travel. Press the SCROLL DOWN ARROW to step the next desired mode, or the “CLEAR” key twice to save changes and exit Calibration mode.

7. Similarly, for Act #2:
 - 7a. Act #2 to Min—Enabl, Min Curr Adjust * XXX.XX — Press YES to force the actuator output to the minimum stop. The message will display ‘At Min’ and the actuator output current will move to its minimum setting. The minimum current value can be adjusted only when the ‘at sign’ (@) is on the bottom line of the display. Press the SELECT key to move the @ symbol between the top and bottom lines. Press the ADJ UP or DOWN keys to change the 0% actuator current level. Press the SCROLL DOWN ARROW to step the next desired mode, or the “CLEAR” key twice to save changes, and exit Calibration mode.
 - 7b. Act #2 to Max—Enabl, Max Curr Adjust * XXX.XX— Press YES to force the actuator output to the maximum stop. The message will display ‘At Max’ and the actuator output current will move to its maximum setting. The maximum current value can be adjusted only when the ‘at sign’ (@) is on the bottom line of the display. Press the SELECT key to move the @ symbol between the top and bottom lines. Press the ADJ UP or DOWN keys to change the 100% actuator current level. Press the SCROLL DOWN ARROW to step the next desired mode, or the “CLEAR” key twice to save changes and exit Calibration mode.
 - 7c. Manually Adjust—Enabl, Stroke Valve XXX.XX — Press the ADJ UP, ADJ DOWN keys from this screen to move the valve’s output current between 0-100% at a 5%/second rate. This allows both the actuator and valve to be tested for binding, play, resolution, linearity, and repeatability.

Press the “YES” key at any time to allow a setting to be directly Entered. The message will display ‘Manual’ when the ENTER mode is allowed. When in the ‘Manual’ mode, press the “ENTER” key, enter the setting desired, then press the “ENTER” key again. This will step the actuator output to a specific position instantly. Press the “ADJ UP/DOWN” or “No” keys at any time to switch back to the “Enabl” mode.

When calibration is complete, 0 to 100% valve position as displayed by the 505 must equal 0 to 100% actual valve travel. Press the SCROLL DOWN ARROW to step the next desired mode, or the “CLEAR” key twice to save changes and exit Calibration mode.

8. **Press the CLEAR key twice to permanently save any minimum or maximum actuator settings into the 505. If variables are tuned or changed but not stored in EEPROM by pressing the CLEAR key twice, then those changes will be lost if power is removed from the control or if the control receives a CPU reset.**

If changes are made to the minimum or maximum current values, they can be recorded on the Program Mode worksheets under the ‘Driver Configurations’ block.

Pressing any available Run Mode key will exit the STROKE ACTUATORS/VALVE mode. Exiting the STROKE ACTUATORS/VALVE mode by a RUN MODE key will not permanently save any calibration changes.



CAUTION

Press the CLEAR key twice to permanently save any minimum or maximum actuator settings into the 505. If variables are tuned or changed but not stored in EEPROM by pressing the CLEAR key twice, then those changes will be lost if power is removed from the control or if the control receives a CPU reset.

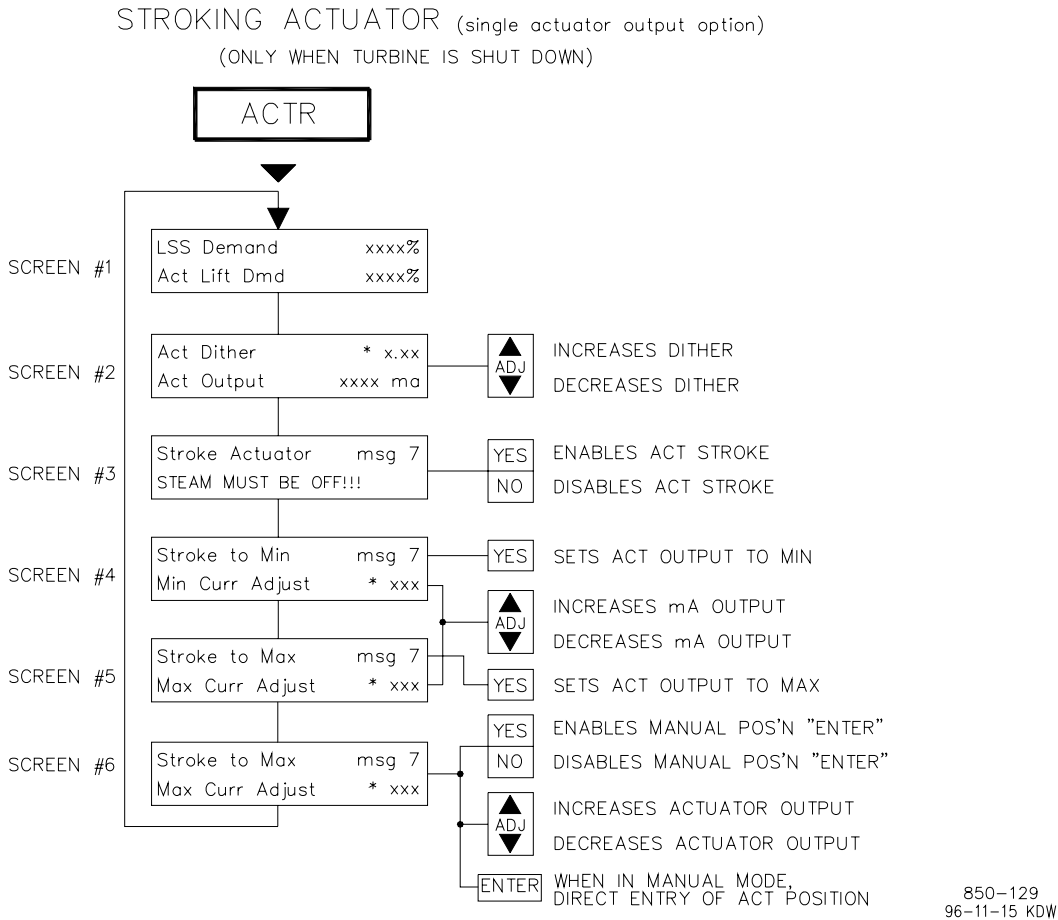

Screen 3 shown only when the unit is shut down.
Screens 4, 5, & 6 shown only when Stroke Actuator is set to YES.

The asterisk (*) denotes a tunable parameter. To adjust this parameter, the "@" symbol must be on the display line containing the asterisk. The@ symbol is moved with the SELECT key.

NOTE: If changes are made to the Min or Max current values, they can be recorded on the PROGRAM MODE worksheets under the "Driver Configuration" header.

Figure 4-5. Stroke Actuator

Stroke Actuator Messages

Message 7

Dsbl'd
Enabl'd
At Min
At Max
Manual

Meaning

Stroke actuators function is disabled
Stroke actuators function is enabled
Actuator output is set to the minimum value (0%)
Actuator output is set to the maximum value (100%)
Actuator output is in manual mode



CAUTION

Press the CLEAR key twice to permanently save any minimum or maximum actuator settings into the 505. If variables are tuned or changed but not stored in EEPROM by pressing the CLEAR key twice, then those changes will be lost if power is removed from the control or if the control receives a CPU reset.

STROKE ACTUATORS (dual actuator output option)
(ONLY WHEN TURBINE IS SHUT DOWN)

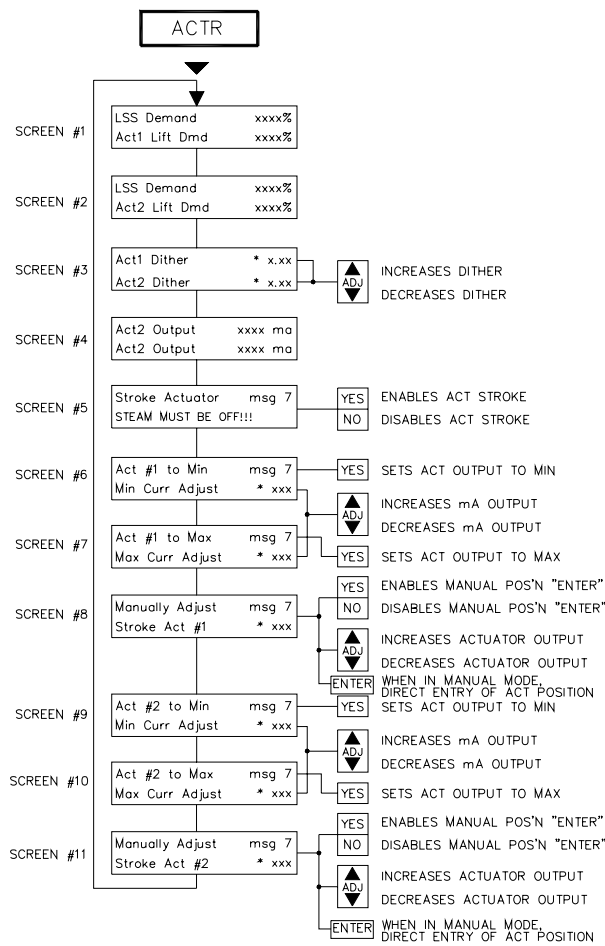

850-130
96-12-10 KDW

Screen 5 shown only when the unit is shut down.
Screens 6-11 shown only when Stroke Actuator is set to YES.

The asterisk (*) denotes a tunable parameter. To adjust this parameter, the "@" symbol must be on the display line containing the asterisk. The @ symbol is moved with the SELECT key.

NOTE: If changes are made to the Min or Max current values, they can be recorded on the PROGRAM MODE worksheets under the "Driver Configuration" header.

Figure 4-6. Stroking Dual Actuators

Chapter 5.

505 Operation

Run Mode Architecture

The 505 is designed to be interfaced with through a user-friendly service panel, discrete and analog input/outputs or Modbus communications. Basic program architecture is illustrated in Figure 5-1. When the control is powered up and after the brief CPU self test has been completed, the control displays a ready status (Controlling Parameter/Push Run or Program). The 505's normal operating architecture is divided into two sections: the Run Mode and the Program Mode. The Program Mode is used to configure the 505 for the specific application and set all operating parameters (see Chapter 4). The Run Mode is simply the normal turbine operation mode and is used to view operating parameters and run the turbine. A Service Mode is also available to make additional on-line adjustments while the unit is running. See Volume 2 for information on the Service Mode.

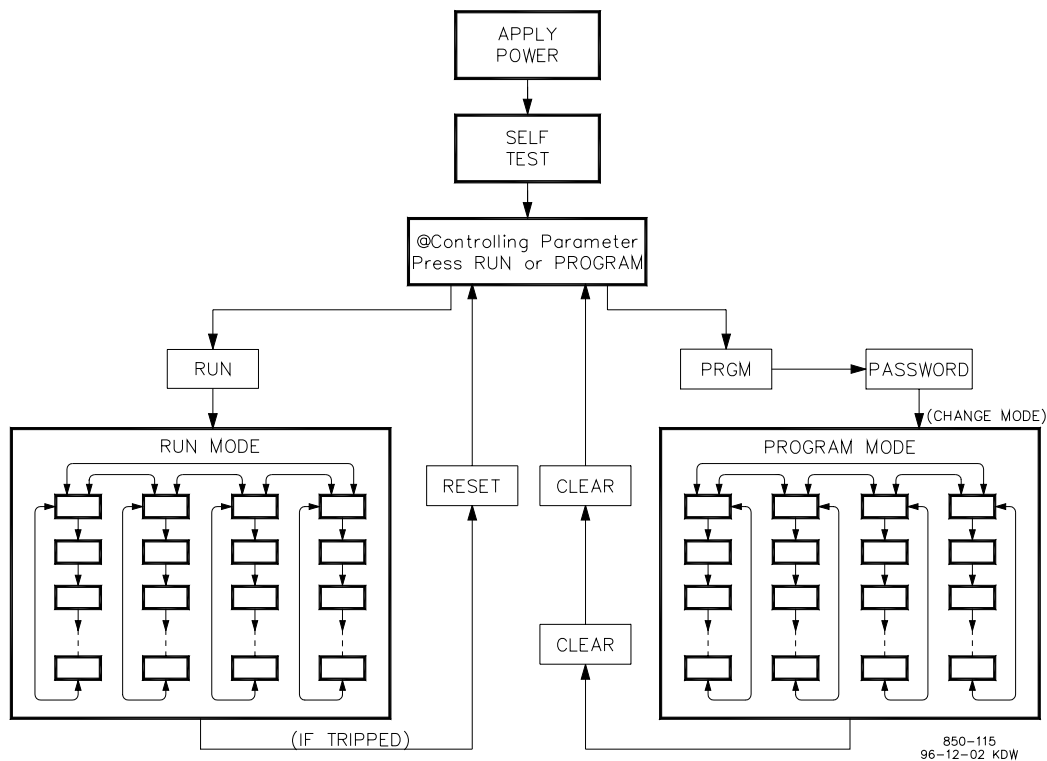
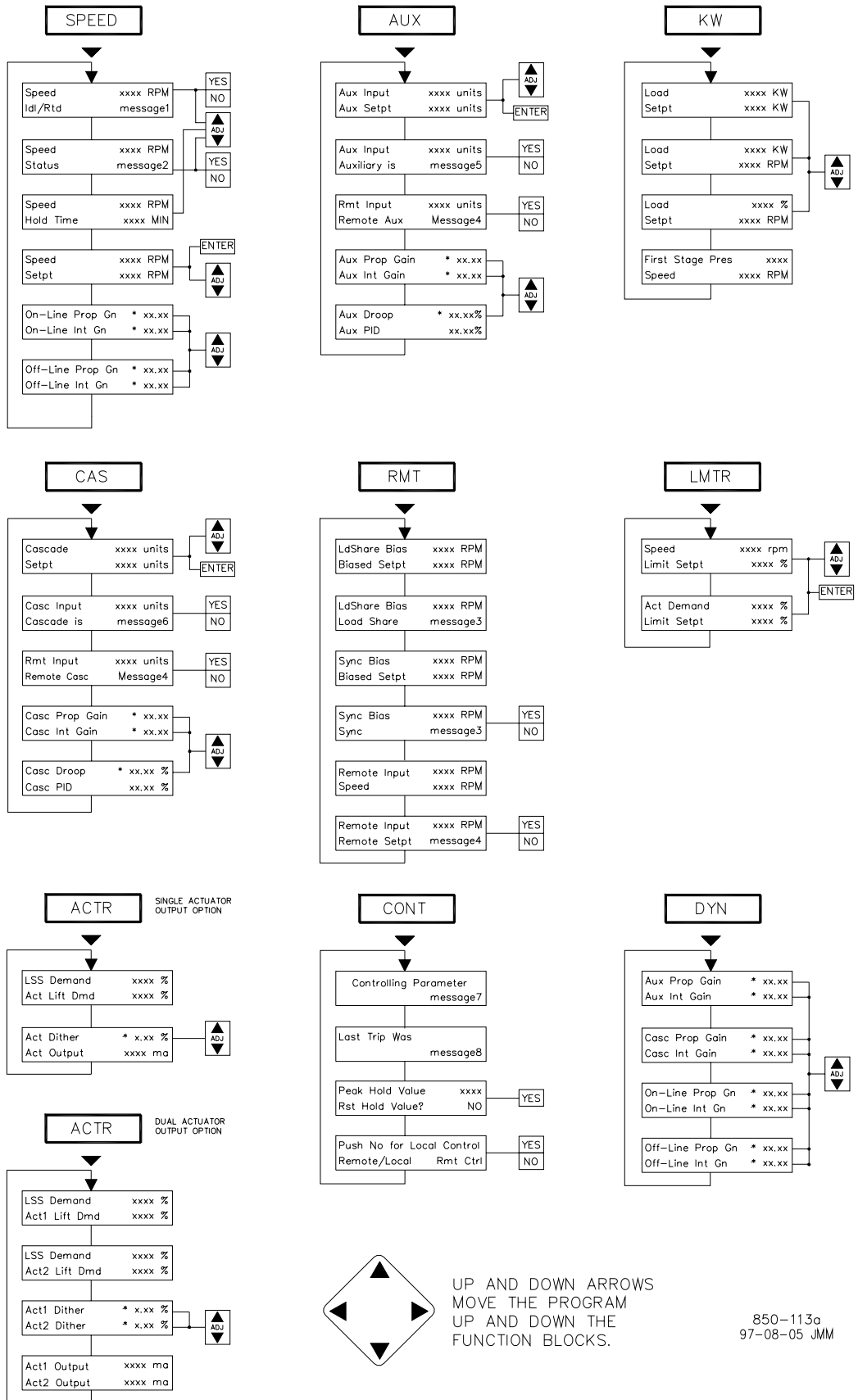

Figure 5-1. Basic Program Architecture

An overview of Run mode keys and screens is shown in Figure 5-2. This diagram shows all of the potential screens that could appear. However, only the screens that are related to the 505's programmed functionality will appear. Figure 5-2 also shows the keys that are active for each screen. The 'hot' keys (Speed, Aux, etc.) are always active if the function is programmed. The ADJUST UP/DOWN, ENTER, YES/NO keys, however, are only active with certain screens. Figure 5-2 can be referred to, when determining what keys are active and what screens will appear on the display.



850-113a
97-08-05 JMM

Figure 5-2a. Overview of Run Mode

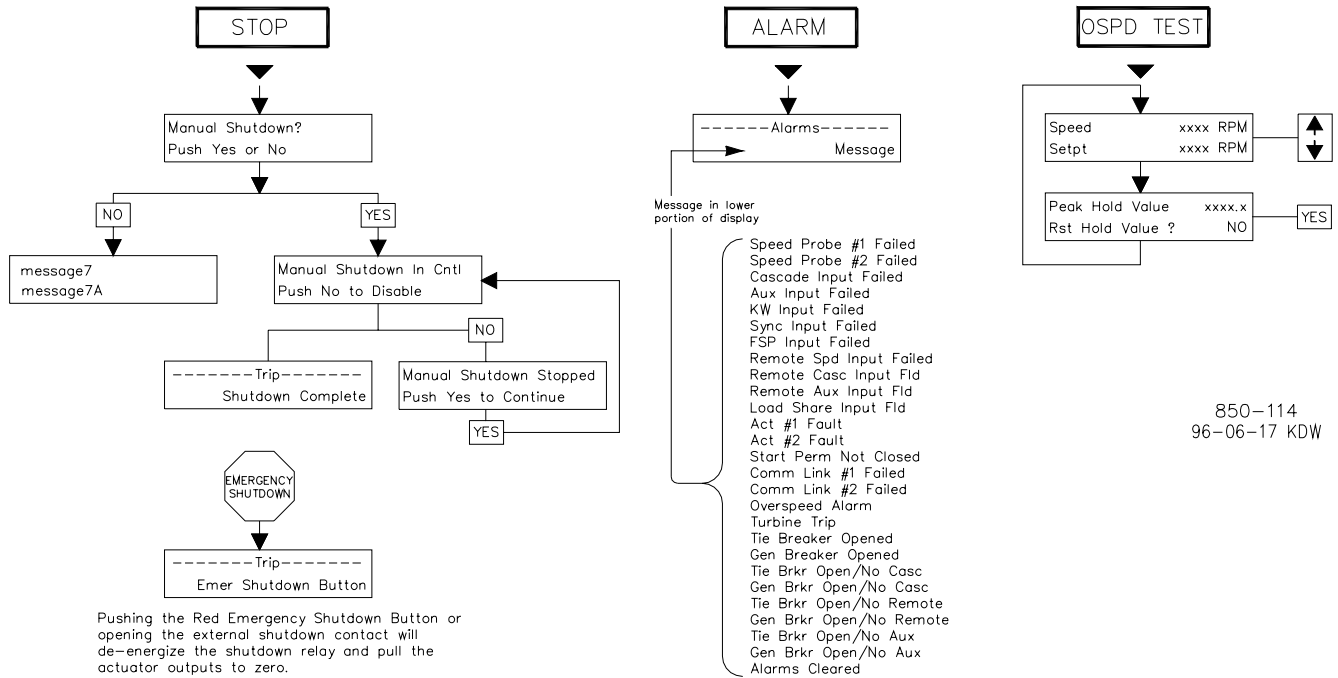

Pushing the Red Emergency Shutdown Button or opening the external shutdown contact will de-energize the shutdown relay and pull the actuator outputs to zero.

Figure 5-2b. Overview of Run Mode

Trip	Controlling Parameter	Remote
<u>Messages</u>	<u>Messages</u>	<u>Messages</u>
Message 8	Message 7	Message 4
External Trip Input	Shutdown	Disabled
Enter Shutdown Button	Controlled Shutdown	Inhibited
Overspeed	Max Actuator	Enabled
All Speed Probes Failed	Valve Limiter	Active
Actuator #1 Fault	Remote Auxiliary	In Control
Actuator #2 Fault	Auxiliary Control	
Aux Input Failed	Configuration Error	Cascade Control
External Trip 2	Start Perm Not Met	Messages
External Trip 3	Ready to Start	Message 6
External Trip 4	Manual Start	Disabled
External Trip 5	Auto Start	Inhibited
Comm Link #1 Trip	Semi Auto Start	Enabled
Comm Link #2 Trip	Idle/Rated Start	In Control
KW Input Failed	Auto Start Sequence	Active/Not Spd Ctrl
Tie Breaker Opened	Frequency/Speed	Active w/Rmt Setpt
Generator Breaker Open	Synchronizing	In Ctrl w/Rmt Setpt
Power Up Trip	Load Share/Speed	
Shutdown Complete	Remote Cascade/Speed	Units Options
	Cascade/Speed	(for Aux/Casc)
	Remote/Speed	psi
Idle/Rated Messages	Speed/On-Line	kPa
<u>Message 1</u>	Speed/Off-Line	MW
Stopped		KW
Speed/Off-Line	Aux Messages	degF
Mvg to Idle	(if using aux enable)	degC
At Idle Spd	Message 5	t/h
In Crit Band	Disabled	k#/hr
Mvg to Rated	Inhibited	#/hr
At Rated Spd	Enabled	kg/cm2
Rtd Inhibited	Active/Not in Ctrl	bar
Idle Inhibited	Active w/Rmt Setpt	atm
	In Control	(none)
Auto Start Messages	Remote Control	
<u>Message 2</u>		
Disabled	Aux Messages	
Halted	(if using aux as a limiter)	
Mvg Low Idle	Message 5	
At Low Idle	Inhibited	
Mvg Hi Idle	Enabled	
In Crit Band	Enabled w/Rmt Setpt	
At High Idle	Active w/Rmt Setpt	
Mvg to Rated	Active/Not Lmtng	
Completed	Control w/Rmt Setpt	
	In Control	
Control Messages		
<u>Message 3</u>		
Disabled		
Inhibited		
Enabled		
In Control		
Remote Control		

Table 5-1. Overview of Run Mode

Keypad and Display

The 505 is a field configurable steam turbine control and operator control panel (OCP) integrated into one package. The 505's service panel consists of a 30-key keypad and LED display located on the front of the control. The LED display has two, 24 character lines that can be used to display operating parameters and trouble-shoot parameters in plain English. The service panel is used to configure the 505, make On-Line program adjustments, and operate the turbine/system. No additional panels are required to operate the turbine, every turbine control function can be from the 505's front panel. However, the turbine can also be operated remotely. Every front panel control operation can be performed remotely through contacts or Modbus communications. For safety purposes, however, the 505's Overspeed Test function cannot be performed through a Modbus link.

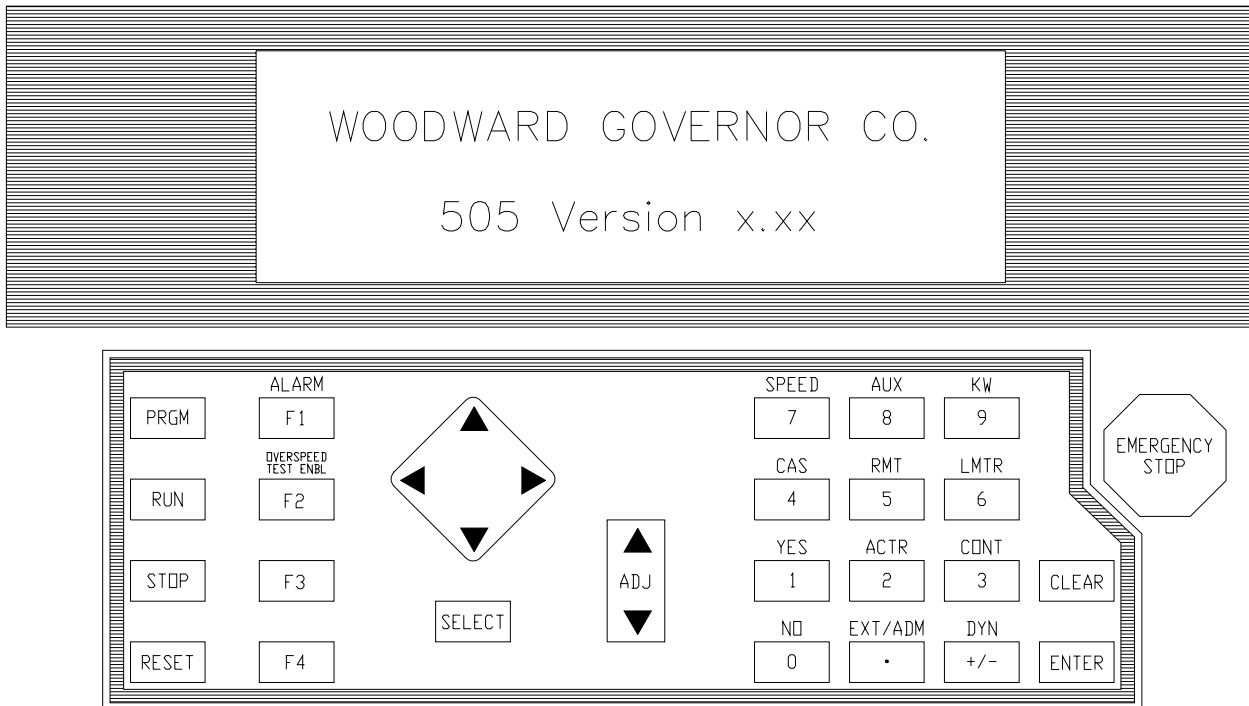

850-084
96-02-06 KDW

Figure 5-3. 505 Keypad and Display

Run Mode Front Panel Keys

For a detailed description of each 505 key functionality see Chapter 1.

Of the thirty front panel keys, not all are active at all times in the Run mode. However, from the 505's service panel, the keys that are active will be apparent since there is immediate display feedback when an active key is pressed. When a respective "Hot" key (Aux, Casc, KW, etc.) function is not programmed, a FUNCTION NOT PROGRAMMED message will appear if the key is pressed. The following are generalizations when determining what keys will function:

- The ADJUST UP/DOWN keys are active when a setpoint is displayed and the setpoint is not in a remote control or tracking mode.
- The ENTER key is active whenever the ADJUST UP/DOWN keys are active. This is when the setpoint is shown on the display and the setpoint is not in remote control or tracking mode.
- The YES/NO keys are active whenever a status indication is shown on the display and an enable/disable function is valid.
- The CAS, AUX, KW, and RMT keys are only active if the function is configured in the Program Mode.
- The SPEED, ACTR, LMTR, CONT, and DYN keys are always active.
- The PRGM, RUN, STOP, RESET, and ALARM keys are always active.
- The F3 and F4 function keys are only active if they are configured.
- The OVERSPEED TEST ENBL is conditionally active (only active when OSPD test is permissible).

Starting Procedures

Refer to the turbine manufacturer's operating procedures for complete information on turbine start up, and Chapter 3 of this manual for a step by step procedure, depending on the start mode selected. The following is a typical start-up procedure:



WARNING

The engine, turbine, or other type of prime mover should be equipped with an overspeed shutdown device to protect against runaway or damage to the prime mover with possible personal injury, loss of life, or property damage.

The overspeed shutdown device must be totally independent of the prime mover control system. An overtemperature or overpressure shutdown device may also be needed for safety, as appropriate.

1. Press the RESET key to clear all alarms and trips. If the 505's RESET CLEARS TRIP setting is programmed "YES", the 505's shutdown relay will reset or energize upon pressing the RESET key after a shutdown. If the RESET CLEARS TRIP OUTPUT setting is programmed "NO", the 505's shutdown relay will reset or energize upon pressing the Reset key ONLY after all trip conditions are cleared.
2. Press the RUN key to initiate the selected start-up mode. The front panel display will automatically jump to the SPEED screen (if auto or manual start is programmed) or to the LMTR screen (if semi-auto start is programmed). If a semi-automatic start mode is configured, the valve limiter must be manually increased to open the control valve.
 - A 'Start Perm Not Closed' alarm will be issued if the application is using a Start Permissive contact input and this contact input was not closed when the RUN command was issued.
3. After the selected start-up mode has been performed, the turbine will operate at the minimum or idle speed setting. The 505's speed setpoint will move to minimum governor speed unless an idle speed is programmed. The Idle/Rated or Auto Start Sequence functions must be programmed for the turbine to control at idle speed. An operator at this time may vary turbine speed through the 505's keypad, external switches or communication links.

The 'Run' and 'Reset' commands can be selected from the 505's service panel, contact input closures (if programmed), or from a Modbus communications link. In addition, the following indications are available through the Modbus links: Speed Setpt Moving to Min, Start Permissive closed, and Start Permissive Not Closed Alarm indication.

Speed Key Screens

Figure 5-4 shows the possible screens that may appear if the SPEED key is pressed. Only the screens related to the Speed control's programmed functionality will be displayed. In addition, the order of the screens may change depending on the status of the control. Screens 4, 5 and 6 will always appear. If idle/rated is programmed, screen 1 will appear. If the auto start sequence is programmed, screens 2 and 3 will appear. Once the auto start sequence is complete, these screens no longer appear.

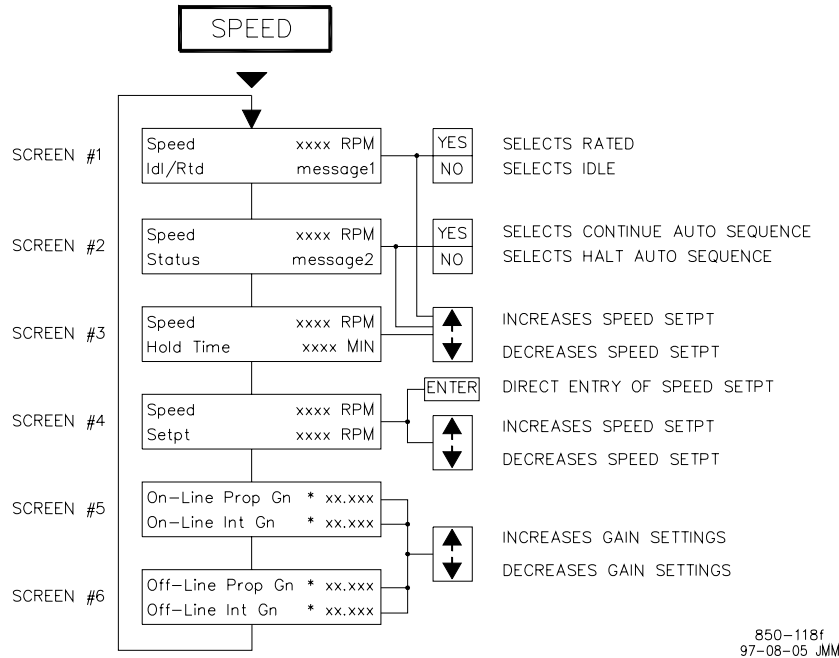

- Screen 1 shown only if Idle/Rated control is configured and speed is less than the rated setpt. Once above rated speed, screen 1 appears after screen 4.
- Screens 2 & 3 are shown only if Auto Start Sequence is configured and speed has not reached the rated setpt.
- Screens 5 & 6 shown only if dynamics adjustments are used.

The asterisk (*) denotes a tunable parameter. To adjust this parameter the "@" symbol must be on the display line containing the asterisk. The @ symbol is moved with the SELECT key.

Figure 5-4. SPEED Key Screens

Idle/Rated Start

For details on the idle/rated startup, refer to Chapter 3. When a RUN command is issued, the 505 automatically displays the SPEED screen and shows the Idle/Rated status. The speed setpoint is instantly set to the actual turbine's speed. To increase the speed to the programmed 'Rated Setpt' setting, select the Rated command. A Rated command can be issued by pressing the front panel YES key from the Idle/Rtd screen (screen 1), closing the Idle/Rated contact (if programmed) or selecting a Go To Rated command from Modbus communications.

When the speed setpoint is ramping to the Rated Setpoint setting it can be stopped at any point that is not within a critical speed avoidance band by issuing a Speed Setpt Raise or Lower command. This can be done by pressing the ADJUST UP or DOWN from the front panel SPEED screen (screens 1,2,3 or 4), closing a Speed Raise/Lower contact input or selecting Speed Raise or Lower from a Modbus communications link.

The Speed setpoint will again ramp to the Rated Speed setting if the Rated command is re-issued. To re-issue the Rated command press the front panel YES key from the Idl/Rtd screen (screen 1), toggle the Idle/Rated contact open and closed again (if programmed) or select Go To Rated from a Modbus communications link.

The Speed setpoint will ramp to the Idle Speed setting upon startup. However, the Idle Speed setting can be re-selected, when conditions allow, (see Chapter 3) by pressing the front panel NO key from the Idl/Rtd screen (screen 1), opening the Idle/Rated contact (if programmed), or selecting Go To Idle from a Modbus communications link.

Another feature of Idle/Rated function is the 'Ramp to Rated' option which allows the Speed setpoint to only move to the Rated Speed setting; Idle is not selectable. This feature is configurable in the Service Mode only. When this feature is used with the Idle/Rated contact input, closing the contact results in the Speed setpoint ramping to the Rated Speed setting and opening the contact stops the speed setpoint ramp—rather than selecting Idle. To continue ramping to the Rated Speed setting, re-close the contact, press the front panel YES key from the Idl/Rtd screen (screen 1) or select Go To Rated from Modbus communications.

Table 5-2 lists the Idle/Rated status messages that may appear on the front panel display and the meanings of each.

Message 1	Meaning
Stopped	Idle/Rated ramp has been stopped
Mvg to Idle	Speed Setpt is moving to idle
At Idle Spd	Speed Setpt is at the idle Setpt
In Crit Band	Speed Setpt is moving through the critical avoidance band
Mvg to Rated	Speed Setpt is moving to the rated Setpt
At Rated Spd	Speed Setpt is at the rated Setpt
Rtd Inhibited	Selection of rated is not allowed
Idle Inhibited	Selection of idle is not allowed

Table 5-2. Idle/Rated Messages

The following indications are available through the Modbus links: Ramping to Idle, At Idle, Turbine in Critical Speed Band, Ramping to Rated, and At Rated. In addition to these indications, the Idle Speed Setpoint and Rated Speed Setpoint analog values are also available.

Auto Start Sequence

When a RUN command is issued, the 505 automatically displays the SPEED screen (unless used with the Semiautomatic start mode) and shows the Status of the Auto Start Sequence (screen 2). The Speed setpoint is instantly set to the turbine's actual speed and the sequence will continue from this point. This sequence is automatic, however the sequence can be halted. Halting the Auto Start Sequence can be performed by pressing the front panel NO key from the Sequence Status screen (screen 2), opening the Halt/Continue contact (if programmed), selecting Halt from a Modbus communications link, or selecting Speed Setpt Raise or Lower. To provide feedback, a relay can be programmed to indicate the Auto Start Sequence is Halted.

The Sequence can be restarted again by pressing the front panel YES key from the Sequence Status screen (screen 2), closing the Halt/Continue contact, or selecting Continue from a Modbus communications link. Table 5-3 lists the Auto Start status messages that may appear on the display and the meanings of each.

Message 2	Meaning
Disabled	Auto Start Sequence is disabled
Halted	Sequence has been halted
Mvg Low Idle	Speed Setpt is moving to low idle
At Low Idle	Speed Setpt is holding at the low idle Setpt
Mvg Hi Idle	Speed Setpt is moving to high idle
In Crit Band	Speed Setpt is moving through the critical avoidance band
At High Idle	Speed Setpt is holding at the high idle Setpt
Mvg to Rated	Speed Setpt is moving to rated Setpt
Completed	Auto Start Sequence is completed

Table 5-3. Auto Start Messages

The following Auto Start Sequence indications are available through the Modbus links: Setpt Moving to Min, Setpt at Low Idle, Ramping to High Idle, Setpt at High Idle, Turbine in Critical Speed Band, Ramping to Rated, and At Rated. In addition to these indications, the Low Idle Speed Setpoint, Low Idle Delay Time, Time Remaining at Low Idle, Low Idle to High Idle Rate, High Idle Speed Setpoint, High Idle Delay Time, Time Remaining at High Idle, High Idle to Rated Rate, Rated Speed Setpoint, Run Time (hours), and Hours Since Trip analog values are also available providing comprehensive sequence information.

Direct Setpoint Entry

The Speed setpoint can be directly set to a specific value, that is not within a critical speed avoidance band, using the ENTER key from the Speed Setpt screen (screen 4). The messages that appear on the display are shown in Figure 5-5. There are limits on the range of the Speed setpoint that can be entered. The Speed setpoint must be below the maximum governor setting and above the idle setting. Also, if the unit is driving a generator and the unit is on-line, the speed setpoint cannot be set below the minimum load setting (tunable in the Service Mode).

The Speed setpoint can also be directly entered from either of the Modbus links, however, the allowed range is between the minimum and maximum governor speed settings. The allowed setpoint range is limited between the minimum load and the maximum governor settings if the unit is driving a generator and the unit is on-line. Both the speed setpoint and the Modbus Entered Speed setpoint are available over the communication link to provide feedback for directly entered Modbus values.

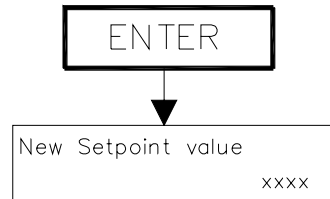

Use Number Keys to set new setpt and press ENTER.

The new setpoint value must be within the allowed setpoint range or the display will issue an error message.

Value xxx.xx Accepted
Press ENTER to continue

The setpoint will move to the new entered value at the "entered rate." The Entered Rate is defaulted to the slow rate setting but can be adjusted in the Service Mode if desired. Selecting the Adjust Up or Adjust Down arrows will stop the setpoint at its present position.

Error Messages:

New value less than min
Press ENTER to continue

New value more than max
Press ENTER to continue

Setpt Entrd in Crit Bnd
Press SPEED key

850-135
96-04-15 KDW

Figure 5-5. Direct Setpoint Entry

Speed Control

Once the turbine is in speed control at minimum governor speed or rated speed, the speed setpoint can be adjusted with the ADJUST UP or DOWN front panel keys from the Speed screen (screen 4), Speed Setpoint Raise or Lower contact inputs, or commands through a Modbus link. In addition the setpoint can be directly entered using the ENTER key from a Setpoint display or through the communication links (see Direct Setpoint Entry above).

The following speed control indications are available through the Modbus links: Speed PID in Control and Speed at or above Min Gov. In addition to these indications the Speed Setpoint, Actual Turbine Speed, Speed Sensor #1 Input, Speed Sensor #2 Input, and Speed Control PID Output analog values are also available.

Overspeed Test Function

The 505's Overspeed Test function allows an operator to increase turbine speed above its rated operating range to periodically test turbine electrical and/or mechanical overspeed protection logic and circuitry. This includes the 505's internal overspeed trip logic and any external overspeed trip device's settings and logic. Figure 5-6 shows the screens that are displayed when the 'OSPD' key is pressed. These will only be displayed when the speed setpoint has been raised to the maximum governor and the unit is Off-Line (if driving a generator). Before these conditions are met, the screen will indicate the overspeed test permissives are not met.

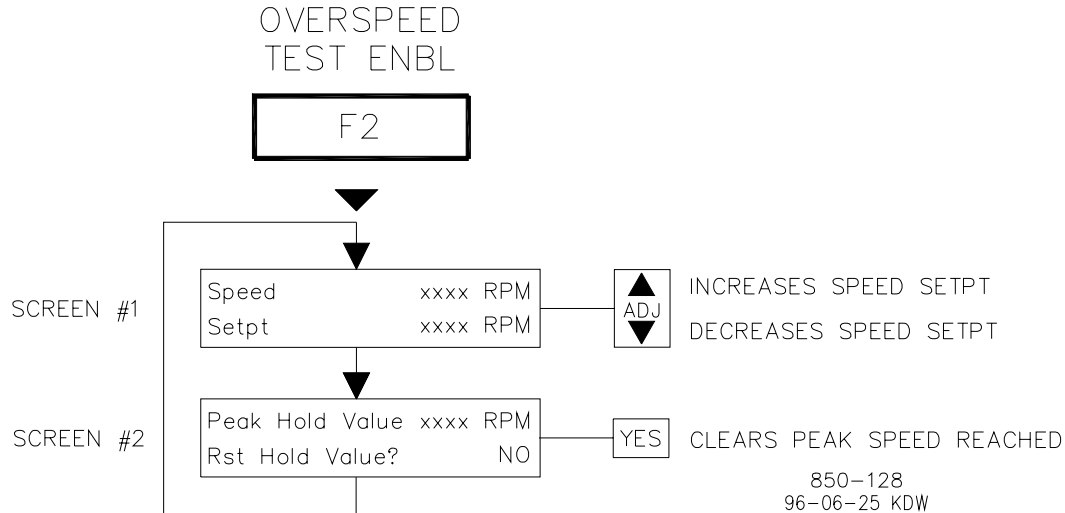

Figure 5-6. Overspeed Test Enable Key Screens

Overspeed Test Procedure

(from the 505's Service Panel)

- Raise the Speed Setpoint to the maximum governor setting.
- If desired, clear the 'Highest Speed Reached' value, to record the highest speed reached during this overspeed test. (Press the OSPD key, scroll down to screen 2 and press the YES key. Note: This value can also be cleared or read from under the Control (CONT) key.
- Press the OSPD key and Adjust Up command at the same time to allow the Speed Setpoint to be raised for testing. The Overspeed Test Enable LED in the OSPD key will turn ON when the setpoint is raised above the maximum governor setting.

If the OSPD key is released, the speed setpoint will move back to the maximum governor setting.

- Once turbine speed reaches the 505's internal OVERSPEED TRIP LEVEL setting, the OSPD key's LED will blink and the screen will flash a 'Speed > Trip' message.
- If the OSPD key is released while the Overspeed Test LED is blinking, the unit will trip on overspeed.

- If an external device's trip setting is being tested the Speed Setpoint can be raised up to the 505's OVERSPEED TEST LIMIT setting, by not releasing the OSPD key and continuing to adjust the 505's Speed Setpoint. The Overspeed Test LED will blink at a faster rate when the OVERSPEED TEST LIMIT is reached, indicating the maximum speed setpoint is reached and the unit should have tripped on the external trip device.

Alternatively the turbine's overspeed logic and circuitry can be tested remotely, by programming an Overspeed Test contact input. The Overspeed Test contact functions as the OSPD key on the 505's service panel. When the conditions outlined in the above procedure are met, closing this contact allows the Speed setpoint to be increased up to the "Overspeed Test limit" setting. The testing procedure is similar to using the OSPD key. An Overspeed Test Enabled relay can be programmed to provide the same status feedback as the front panel Overspeed Test LED.

The Overspeed Test function cannot be performed over the Modbus communications, however, the Overspeed Test Permissive, Overspeed Test In Progress, Overspeed Alarm, and Overspeed Trip indications are available through Modbus.

F3 and F4 Keys

The F-key (F3 & F4) screens appear only when programmed for a specific function. The screens that appear will vary depending on the function programmed. The F-keys can be programmed to perform a variety of functions including:

Local/Remote	Casc Control Enable
Idle/Rated	Remote Casc Setpt Enable
Halt/Continue Auto Start Sequence	Aux Control Enable
Remote Speed Setpt Enable	Remote Aux Setpt Enable
Sync Enable	Energize Relay Output
Freq Arm/Disarm	

In the RUN mode, the assigned function may be selected or deselected by pressing the assigned function key, then the Yes or No keys respectively. The screen will display the present status of the function and prompt the appropriate (Yes/No) key required to change the status.

Limiter (LMTR) Key Screens

Figure 5-7 shows the screens that appear when the LMTR key is pressed. These screens are always active and always displayed. During normal operation the Valve Limiter setting is at 100% and not limiting.

Typically, the only time this parameter is adjusted is during a start sequence or to troubleshoot system dynamics problems. The actuator demand and the limiter setpoint can be viewed from screen 2. To manually position the governor valve with the Valve Limiter setpoint, the limiter setpoint must be decreased below the actuator demand signal (LSS bus output). Once below or equal to this signal, the limiter setting will be the actuator output signal and thus governor valve position will be set manually by the limiter.

The valve limiter can be adjusted with the ADJUST UP or DOWN front panel keys from any Limiter screen, Valve Limiter Raise or Lower contact inputs (if programmed), or commands through a Modbus link. In addition the setpoint can be directly entered using the ENTER key from any Limiter screen.

The following valve limiter indications are available through the Modbus links: Valve Limiter at Min, Valve Limiter at Max, and Valve Limiter In Control of actuator output. In addition to these indications the Valve Limiter Setpoint, Actuator LSS, Actuator #1 Output and Actuator #2 Output analog values are also available.

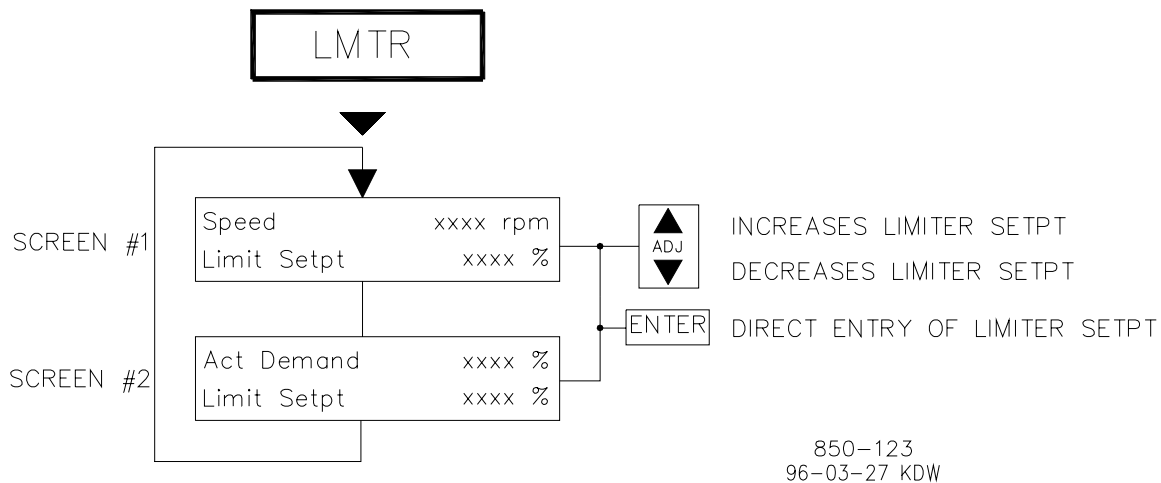
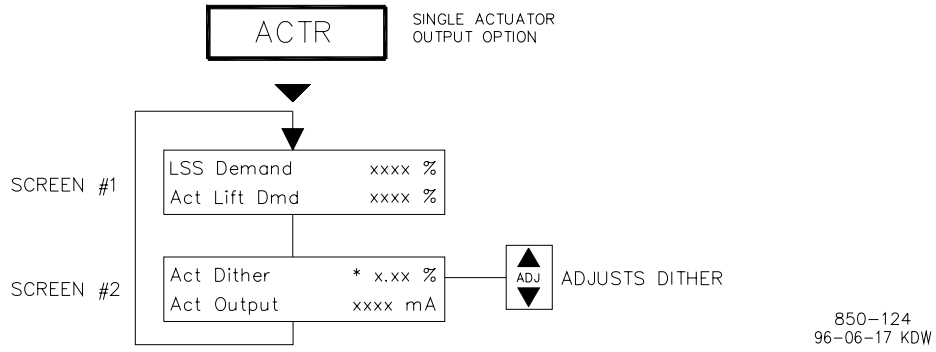

Figure 5-7. LMTR Key Screens

Actuator (ACTR) Key Screens

Figure 5-8 shows the possible screens that may appear if the ACTR key is pressed. The only parameter that can be adjusted from these screens is the dither setting. To adjust the dither setting (if required), the @ symbol must be on the display line containing the asterisk/dither value to tune. The @ symbol is moved using the SELECT key.

The dual actuator output option displays both actuator output demand values as well as the LSS demand. If the Actuator #2 offset is zero, all of these values will be the same. If the offset is not zero, the LSS will display the total lift demand for both outputs. The LSS will be zero when Actuator #1 is zero and reach 100% when Actuator #2 reaches 100%. The communications links will display the Actuator LSS, Actuator #1 Demand, Actuator #2 Demand values as well as the actual Actuator Output Current for both actuators in milliamps.



The asterisk (*) denotes a tunable parameter. To adjust this parameter the "@" symbol must be on the display line containing the asterisk. The @ symbol is moved with the SELECT key.

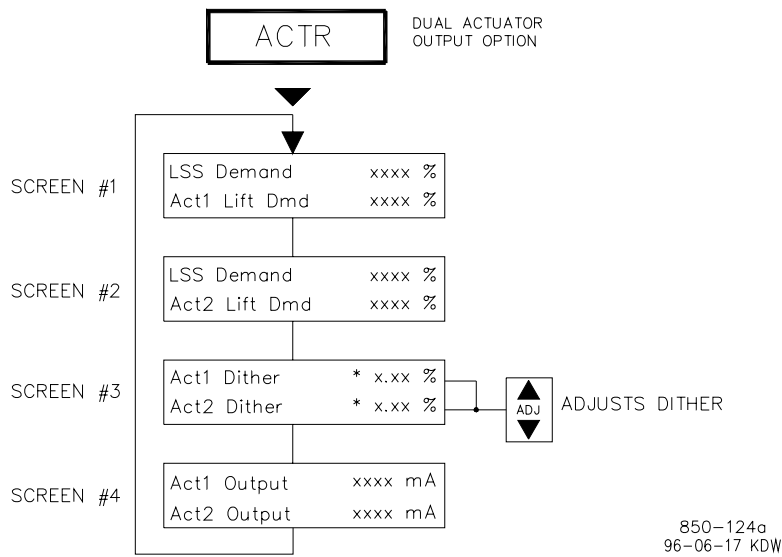

The asterisk (*) denotes a tunable parameter. To adjust this parameter the "@" symbol must be on the display line containing the asterisk. The @ symbol is moved with the SELECT key.

Figure 5-8. ACTR Key Screens

Control (CONT) Key Screens

Figure 5-9 shows the screens that appear when the CONT key is pressed. The CONT key allows operators to monitor what 505 parameter (PID or limiter) is controlling governor valve position (screen 1). From screen 2 the cause of the last turbine shutdown can be viewed and from screen 3 the highest turbine speed reached can be viewed and cleared, if desired.

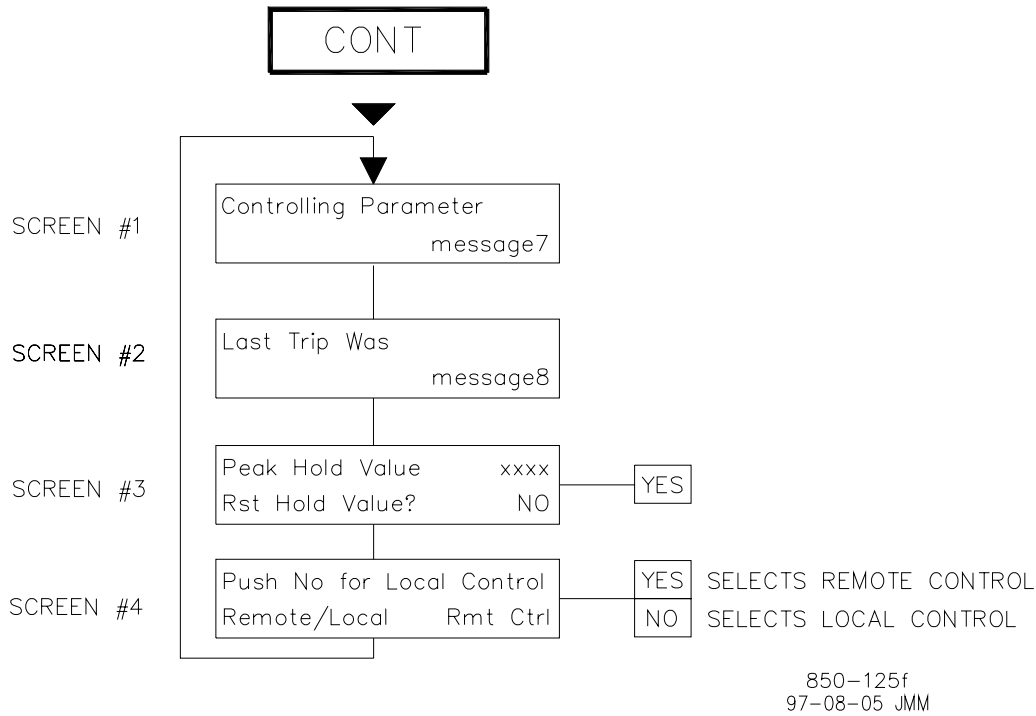

● Screen 4 shown only if Local/Remote is configured.

Figure 5-9. CONT Key Screens

Table 5-4 shows a complete listing of all possible controlling parameters and their meanings.

Message 7	Meaning
Shutdown	Control is tripped
Controlled Shutdown	A controlled shutdown is being executed
Start Perm Not Met	The start permissive contact input is not closed
Max Actuator	The actuator output is at its maximum position
Valve Limiter	The Valve Limiter is in control of the actuator output
Ready to Start	The unit's start permissives are OK and the unit is ready to start
Manual Start	The 505 is running and in the Manual start mode
Auto Start	The 505 is running and in the Automatic start mode
Semi Auto Start	The 505 is running and in the Semi-automatic start mode
Idle/Rated Start	The 505 is running and in the Idle/Rated sequence mode
Auto Start Sequence	The 505 is running and in the Automatic Start Sequence mode
Remote/Speed	Speed PID is in control, the Speed Setpoint is in remote control
Speed/On-Line	Speed PID is in control using On-Line dynamics
Speed/Off-Line	Speed PID is in control using Off-Line dynamics
Frequency/Speed	Speed PID is in control with the gen. breaker closed and tie breaker open
Synchronizing	Speed PID is in control with the Synch. analog input biasing its setpoint
Load Share/Speed	Speed PID is in control with Sync/Ld Share analog input biasing its setpoint
Auxiliary Control	Aux PID is in control of the actuator output
Remote Auxiliary	Aux PID is in control and the Aux Setpt is in remote control
Cascade/Speed	Casc & Speed PIDs are in control
Rmt Cascade/Speed	Casc & Speed PIDs are in control, and Casc Setpt is in remote control
Configuration Error	The 505 program has been configured incorrectly

Table 5-4. Controlling Parameter Messages

For a complete listing of Shutdown/Trip causes, refer to the Trips section later in this chapter.

The Controlling Parameter and Highest Speed Reached values are also available through the Modbus links.

Dynamics (DYN) Key Screens

Figure 5-10 shows the possible screens that may appear if the DYN key is pressed. This mode is used to adjust controller dynamics. When the DYN key is pressed, the dynamics for the parameter that is in control, at that time will be displayed. To tune the dynamic settings of the other controllers, the key for the specific controller must be pressed and the STEP DOWN selected until the dynamics parameters appear. For information on tuning PIDs, refer to Chapter 3 of this manual.

To adjust the gain settings, the @ symbol must be on the respective display line of the value to be adjusted. The @ symbol is moved by pressing the SELECT key.

The controller dynamics are adjustable from the 505's Service panel only, they cannot be adjusted remotely.

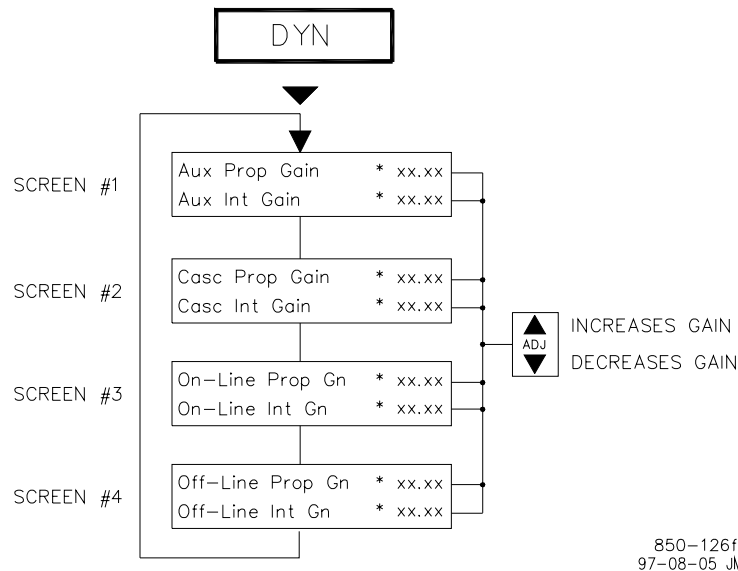

- Screen displayed varies with the parameter "in control" of the actuator output. Only the parameter "in control" will be displayed.
- Screen 1 shown only if Auxiliary Control is configured and Aux is in control.
- Screen 2 shown only if Cascade Control is configured and Casc is in control.

The asterisk (*) denotes a tunable parameter. To adjust this parameter, the "@" symbol must be on the line containing the asterisk. The @ symbol is moved with the SELECT key.

Figure 5-10. DYN Key Screens

Stop Key Screens

Figure 5-11 shows the possible screens that may appear if the STOP key is pressed. The STOP key is used to perform a controlled/manual turbine shutdown or stop. To perform a Manual Shutdown, select YES from the Status screen or close the Controlled Shutdown contact input (if programmed) or select Controlled Shutdown from a Modbus communications link. This function can be stopped or aborted by pressing the front panel NO key from the Manual Shutdown Status screen, opening the contact, or selecting Abort Controlled Shutdown from a Modbus communications link.

The Controlled Shutdown sequence can be restarted again by pressing the front panel YES key from the Manual Shutdown Status screen, re-closing the contact, or re-selecting Controlled Shutdown from a Modbus communications link. The link will display the Controlled Stop In Progress and Controlled Shutdown Trip completed status'.

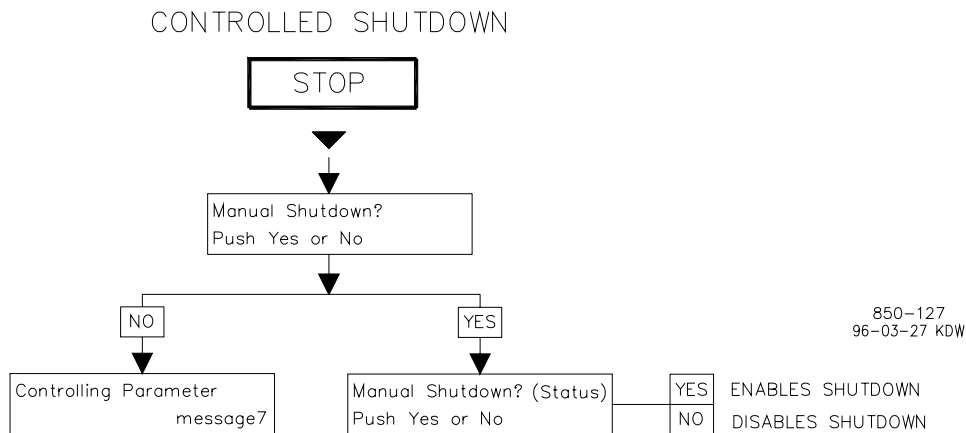

The speed setpoint moves to the minimum (zero) at the fast rate. Once at the minimum, the valve limiter moves to its minimum position. At the minimum valve limiter position, a trip is issued. The shutdown relay will de-energize and the actuator outputs are pulled to zero. The front panel displays the following:

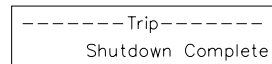
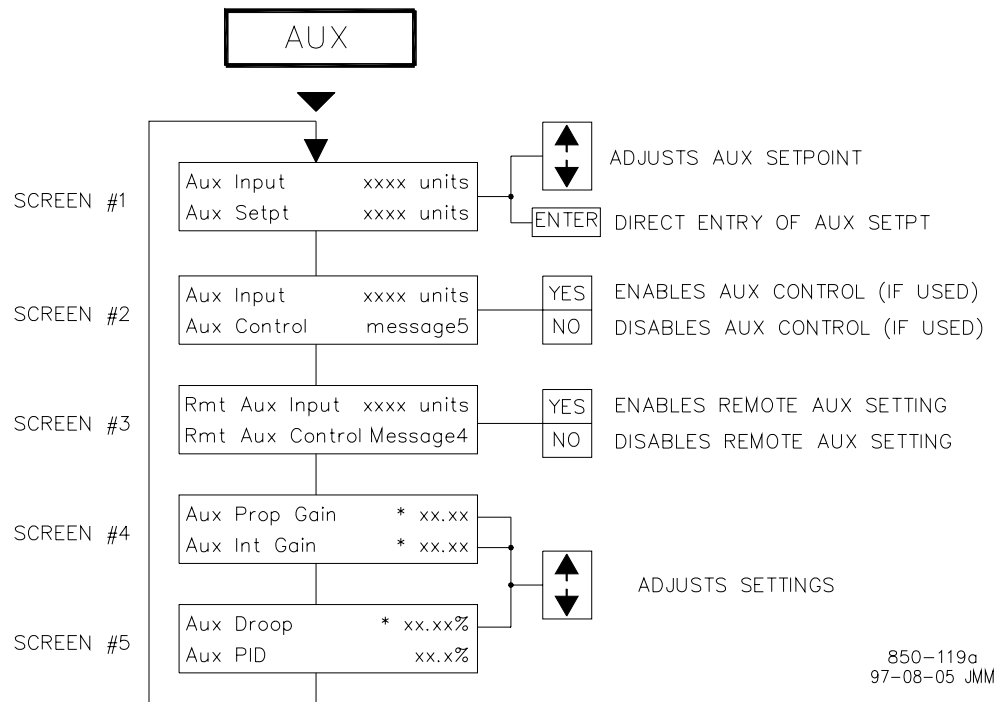

Figure 5-11. STOP Key Screens

Auxiliary (Aux) Key Screens

For this key to be active, the Auxiliary function must be programmed. Figure 5-12 shows the possible screens that may appear if the AUX key is pressed. Only the screens related to the Auxiliary control's programmed functionality will be displayed. If Remote Aux Setpoint is programmed, screen 3 will appear. The Auxiliary PID dynamics and droop level (if required) can be adjusted from these screens.



Screen 3 shown only if Remote Auxiliary control is configured.
Screen 4 shown only if dynamics adjustments are used.

The asterisk (*) denotes a tunable parameter. To adjust this parameter the "@" symbol must be on the display line containing the asterisk. The @ symbol is moved with the SELECT key.

"Units" are determined by the AUX UNITS configured.

Figure 5-12. AUX Key Screens

Auxiliary as a Controller (using Enable/Disable)

When auxiliary control is used as a controller, as opposed to a limiter, the enable/disable function is used to select Auxiliary control. Auxiliary control can be enabled by pressing the front panel YES key from the Status screen (screen 2) or by closing the Aux Control Enable/Disable contact (if programmed) or by selecting Aux Enable from either Modbus communications link.

With this configuration, prior to enabling Auxiliary control, the Auxiliary setpoint tracks the Auxiliary analog input to accommodate bumpless transfers between control modes. As a result, the Auxiliary setpoint cannot be changed until the Auxiliary PID is enabled. Once enabled, the Auxiliary setpoint can be changed by pressing the ADJUST UP or DOWN from the front panel Aux Setpt screen (screen 1), closing a Aux Setpt Raise/Lower contact input, or selecting Aux Setpoint Raise or Lower from either Modbus communications link. In addition, the Auxiliary setpoint can be directly set to a value by pressing the front panel ENTER key from the Auxiliary Setpoint screen or by "Entering" a new Auxiliary Setpoint through either Modbus communications link.

Auxiliary control is disabled by pressing the front panel NO key from the Aux Status screen (screen 2), opening the Aux Control Enable/Disable contact (if programmed), or selecting "Aux Disable" from either Modbus communications link see Table 5-5). Auxiliary control is also disabled if Cascade control is enabled, or Remote Speed Setpoint control is enabled. Aux control is disabled and 'inhibited' if a controlled shutdown is selected, the Auxiliary input fails or the unit shuts down. Auxiliary control can be enabled but not active if the generator and/or utility tie breaker disable features are programmed.

Message 5	Meaning
Disabled	Aux control is disabled
Inhibited	Aux is inhibited and cannot be enabled
Enabled	Aux is enabled but not in control due to gen/tie breaker status
Active/Not In Ctrl	Aux is active but the PID is not in control (valve limiter control)
Active w/Rmt Setpt	Aux is active but not in control and the Setpt is in remote control
In Control	Aux is active and in control of the actuator output
Remote Control	Aux is in control and the Setpt is in remote control

Table 5-5. Auxiliary Messages (if using Aux enable)

Auxiliary as a Limiter (not using Enable/Disable)

When Auxiliary control is used as a limiter, as opposed to a controller, the enable/disable function is not used and Auxiliary control is always enabled. The Auxiliary setpoint can be changed by issuing Auxiliary Setpt Raise or Lower commands. This can be done by pressing the ADJUST UP or DOWN from the front panel Aux Setpt screen (screen 1), closing the Auxiliary Setpoint Raise/Lower contact inputs, or selecting Auxiliary Setpoint Raise or Lower from either Modbus communications link. In addition, the Auxiliary setpoint can be directly set to a value by selecting the front panel ENTER key from the Aux Setpt screen or "Entering" a new Aux Setpt through either Modbus communications link.

Auxiliary control is inhibited if a controlled shutdown is selected, the Auxiliary input fails, or the unit shuts down. See Table 5-6. Auxiliary control can be 'enabled' but not 'active' if the generator and/or utility tie breaker disable features are programmed. Aux will be In Control if the Auxiliary PID is active and limiting the Auxiliary input parameter.

Message 5	Meaning
Inhibited	Aux is inhibited and is not active
Enabled	Aux is enabled but generator or tie breaker is open
Enabled w/Rmt Setpt	Aux is enabled but not active and the Setpt is in Remote control
Active w/Rmt Setpt	Aux is active but not limiting and the Setpt is in Remote control
Active/Not Lmtng	Aux is active but not limiting the actuator output
Control w/Rmt Setpt	Aux is in control (limiting) and the Setpt is in Remote control
In Control	Aux is in control and limiting the actuator output

Table 5-6. Auxiliary Messages (if using Aux as a limiter)

The following auxiliary control indications are available through the Modbus links: Aux is Enabled, Aux is Active, Aux is In Control, Aux is Inhibited, Aux Active/Not Limiting, Aux Active/Not In Control, and the Aux Input Failed Alarm. In addition to these indications the Aux Setpoint, Aux Input, and Aux PID Output analog values are also available.

Relay indications can be programmed to indicate Aux Control Active, Aux Control Enabled, or Aux PID In Control status'.

Remote Aux Setpoint

The Remote Auxiliary Setpoint function is used to allow the Auxiliary setpoint to be remotely positioned by an analog input. When configured to an analog input, this function/input can be enabled by pressing the front panel YES key from the Remote Aux Status screen (screen 3), closing the Remote Aux Setpoint Enable/Disable contact (if programmed), or selecting Remote Aux Enable from either Modbus communications link.

Remote Auxiliary Setpoint is disabled by pressing the front panel NO key from the Remote Aux Status screen (screen 3), opening the Remote Aux Control Enable/Disable contact (if programmed), or selecting Remote Aux Disable from either Modbus communications link. See Table 5-7 for all possible Remote Aux control messages.

Message 4	Meaning
Disabled	Remote Aux Setpoint is not selected
Inhibited	Remote Aux Setpoint is inhibited and cannot be enabled
Enabled	Remote Aux Setpoint is enabled but not in control of the Setpt
Active	Remote Aux Setpoint is in control, Aux PID is not controlling the actuator
In Control	Remote Aux Setpoint is in control, Aux PID is controlling the actuator

Table 5-7. Remote AUX Messages

The following remote auxiliary control indications are available through the Modbus links: Remote Aux is Enabled, Remote Aux is Active, Remote Aux is In Control, Remote Aux is Inhibited, and Remote Aux Input Failed Alarm. In addition to these indications, the Remote Aux Input Setpoint is also available. Relay indications can be programmed to indicate Remote Aux Control Active and Remote Aux Control Enabled status'.

Remote/Speed Bias (RMT) Key Screens

For this key to be active, the Remote Speed Setting, Synchronizing, or Load Sharing functions must be programmed. The Synchronizing and Load Sharing functions are configured by programming the respective function to an analog input. Figure 5-13 shows the possible screens that may appear if the RMT key is pressed. Only the screens related to the functions programmed will be displayed. Screens 3 and 4 appear when the Synchronizing analog input is programmed, screens 1 and 2 appear when Sync/Load Sharing analog input is programmed, and screens 5 and 6 appear when Remote Speed Setpoint input is programmed.

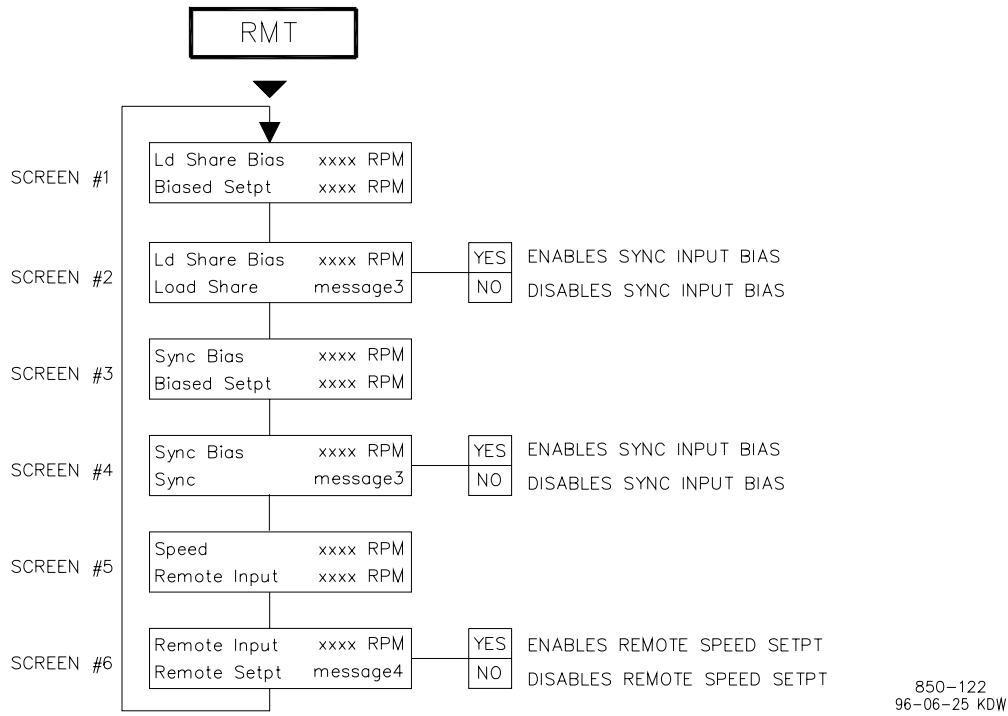

Screens 1 & 2 are shown only if Load Sharing control or Sync/Ld Sharing is configured.
 Screens 3 & 4 are shown only if Synchronizing is configured and Load Sharing is not.
 Screens 5 & 6 are shown only if Remote speed Setting control is configured.

Figure 5-13. RMT Key Screens

Remote Speed Setpoint

The Speed PID setpoint can be remotely set by an analog input, if programmed. This Remote Speed Setpoint input can be enabled by pressing the front panel YES key from the Remote Speed Status screen (screen 6), closing the Remote Speed Setpoint Enable/Disable contact (if programmed), or selecting Enable Remote Speed Setpt Control from either Modbus communications link (see Table 5-8).

Remote Speed Setpoint input is disabled by pressing the front panel NO key from the Remote Speed Status screen (screen 6), opening the Remote Speed Control Enable/Disable contact (if programmed), or selecting Disable Remote Speed Setpt Control from either Modbus communications link.

Message 4	Meaning
Disabled	Remote is not selected
Inhibited	Remote is inhibited and cannot be enabled
Enabled	Remote is enabled but not in control of the Setpt
Active	Remote is in control of the Setpt but not in control of the actuator output
In Control	Remote is in control of the Setpt and in control of the actuator output

Table 5-8. Remote Speed Messages

The following Remote control indications are available through the Modbus links: Remote Speed Setpt is Enabled, Remote Speed Setpt is Active, Remote Speed Setpt is In Control, Remote Speed Setpt is Inhibited, and the Remote Speed Setpt Input Failed Alarm. In addition to these indications, Remote Speed Setpt Input analog value is also available.

Relay indications can be programmed to indicate Remote Speed Setpt Active and Remote Speed Setpt Enabled status'.

Synchronizing and/or Loadsharing

The Synchronizing feature allows an analog input to bias the speed setpoint when using a DSLC for synchronization. The Synchronizing analog input is enabled by pressing the front panel YES key from the Sync Status screen (screen 4), closing the Sync Enable contact (if programmed), issuing an enable demand through a "F" key, or selecting Sync Enable from either Modbus communications link.

The Synchronizing & Load Sharing feature allows an analog input to bias the speed setpoint when using a DSLC for synchronizing and load sharing. Load sharing is enabled automatically based on the generator and utility tie breaker status inputs. The Sync/Load Share input is enabled by pressing the front panel YES key from the Sync Status screen (screen 4), closing the Sync/Ld Share Enable contact (if programmed), issuing an enable command through a "F" key, or selecting Sync Enable from either Modbus communications link.

The Synchronizing or Sync/Ld Share inputs are disabled by pressing the front panel NO key from the respective Status screen, opening the respective function's Enable/Disable contact (if programmed), or selecting the Sync Disable command from either Modbus communications link. The Synchronizing analog input is automatically disabled when the generator breaker closes, but can be re-enabled with the generator breaker closed, to allow synchronization across a tie line breaker. The Sync/Load Share analog input is automatically disabled when the generator breaker opens. Table 5-9 lists the possible synchronizing/loadsharing control messages.

Message 3	Meaning
Disabled	Function is in disabled mode
Inhibited	Function is inhibited and cannot be enabled
Enabled	Function is enabled but not in control of the Setpt
In Control	Function is in control of the actuator output

Table 5-9. Control Messages

The following synchronizing and loadsharing control indications are available through the Modbus links: Generator Breaker Status, Utility Tie Breaker Status, Frequency Control, Sync is Enabled, Sync or Loadshare is In Control, Sync or Loadshare is Inhibited, and the Sync/Loadshare Input Failed Alarm. In addition to these indications, Sync/Loadshare Input analog value is also available.

Relay indications can be programmed to indicate Sync Enabled, Sync/Loadshare Enabled, Loadshare Control and Frequency Control status'.

Unit Load (KW) Key Screens

This key is active if the unit is programmed for a generator application or if a first stage pressure analog input is configured. Figure 5-14 shows the possible screens that may appear if the KW key is pressed. Only the screens related to the functions programmed will be displayed. If a first stage pressure analog input is configured, screen 4 will appear. When the unit is programmed for a generator application, only one of the first three screens will appear, depending on the mode of operation (governor valve position droop or KW/unit load input signal droop).

Screen 1 or 2 is displayed when the unit is programmed with a KW/Unit Load analog input and the input is not failed. Screen 3 is displayed if no KW/Unit Load analog input is programmed or the input is failed. When the units on the 'Load' parameter are 'KW' or 'MW', the screen is displaying actual load units from the KW/Unit Load analog input. When units on the 'Load' parameter is '%', the screen is displaying a calculated load value.

The bottom line of the display on screens 1, 2, & 3 show the Load Setpoint. This value and units change depending on the droop mode the 505 is presently using. If the droop is based on the KW input, the units are in 'KW' or 'MW'. If the droop is based on the KW input, the units are in 'KW' or 'MW'. If the droop is LSS/Speed Demand (governor valve position), the units are in 'rpm'.

The Load Setpoint can be changed when the unit is On-Line from screens 1, 2, or 3 by selecting the ADJUST UP or DOWN. In addition, the Load Setpt can be adjusted by closing a Speed Setpoint Raise/Lower contact inputs or selecting Speed Setpoint Raise or Lower commands from either Modbus communications link. In addition, the Load setpoint can be directly set to a value by pressing the ENTER key from the SPEED screen and entering a speed setpoint value, or Entering a new Speed/Load Setpoint through either Modbus communications link.

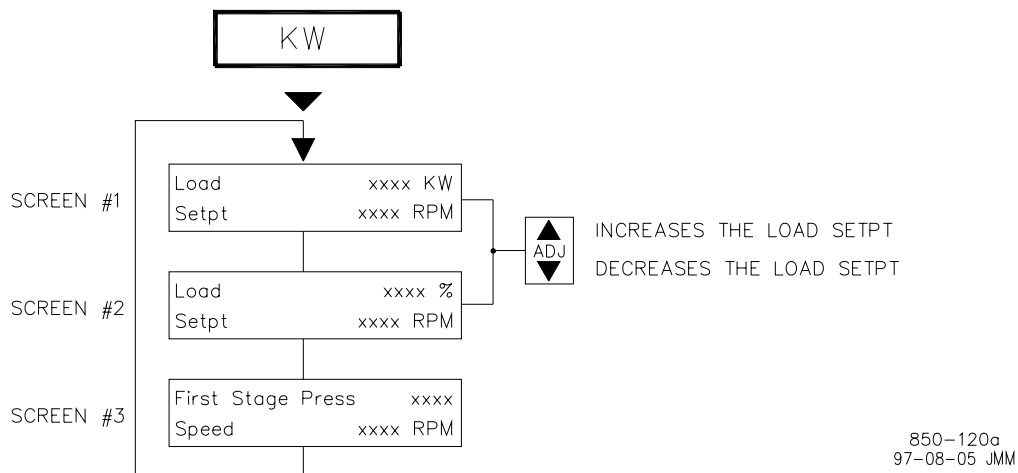

- Screen 1 shown only if a KW analog input is programmed and input is not failed.
- Screen 2 shown only if no KW analog input is programmed or KW input is failed.
- Screen 3 shown only if a First Stage Pressure analog input is programmed.

NOTE

- The "KW" units can be changed to "MW" in the Service mode if desired.
- If no kw input is programmed, the Load units and value will be in calculated load percent.

Figure 5-14. KW Key Screens

Cascade (CAS) Key Screens

For this key to be active, the Cascade function must be programmed. Figure 5-15 shows the possible screens that may appear if the CAS key is pressed. Only the screens related to the Cascade functionality programmed will be displayed. Only when the Remote Cascade Setpoint is programmed, will screen 3 appear. The Cascade PID dynamic and droop values can be adjusted from these screens.

Cascade control can be enabled by pressing the front panel YES key from the Status screen (screen 2), closing the Cascade Control Enable/Disable contact (if programmed), or selecting Cascade Enable from either Modbus communications link.

Cascade control is disabled by pressing the front panel NO key from the Cascade Status screen (screen 2), opening the Cascade Control Enable/Disable contact (if programmed), or selecting Cascade Disable from either Modbus communications link. Cascade control is also disabled if Auxiliary control is enabled or Remote Speed Setpoint input is enabled. Cascade control is disabled and 'inhibited' if a controlled shutdown is selected, the cascade input fails, or the unit shuts down. Cascade control can be 'enabled but not active' if the generator and/or utility tie breaker are open. Since the Cascade PID controls through the Speed setpoint and Speed PID, Cascade will only be "In Control" when the Speed PID is "In Control" of the actuator output. See Table 5-10 for all possible cascade control messages.

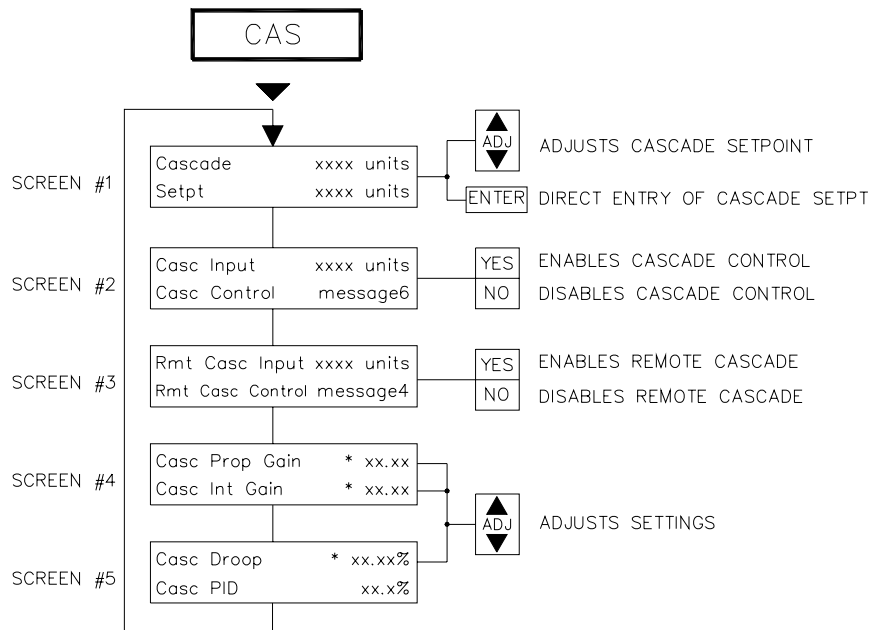

Screen 3 shown only if Remote Cascade control is configured.
Screen 4 shown only if dynamics adjustments are used.

The asterisk (*) denotes a tunable parameter. To adjust this parameter, the "@" symbol must be on the display line containing the asterisk. The @ symbol is moved with the select key.

"Units" are determined by the cascade units configured.

850-121a
97-08-05 JMM

Figure 5-15. CAS Key Screens

The Cascade setpoint can be configured to either track the input for bumpless transfer into control or remain at the last setting. When using the tracking option, the cascade setpoint cannot be changed until Cascade control is enabled.

The Cascade setpoint can be changed by pressing the ADJUST UP or DOWN keys from the Cascade setpoint screen (screen 1), closing a Cascade Setpt Raise/Lower contact input, or selecting Cascade Setpoint Raise or Lower commands from either Modbus communications link. In addition, the Cascade setpoint can be directly set to a value by pressing the front panel ENTER key from the Cascade Setpt screen or by Entering a new Cascade Setpt through either Modbus communications link.

The Cascade Setpt Raise/Lower contact inputs have a dual function. If either contact is closed and the Cascade control is active, the cascade setpoint will be adjusted. If either contact is closed and the cascade control is not active, the Speed setpoint will be adjusted. The advantage of this feature is that only one set of raise/lower switches is required to adjust either setpoint.

The Cascade setpoint can be directly set to a value by selecting the front panel ENTER key from the Cascade Setpt screen or by Entering a new Cascade Setpt through either Modbus communications link.

Message 5	Meaning
Disabled	Cascade control is disabled
Inhibited	Cascade is inhibited and cannot be enabled
Enabled	Cascade is enabled but not in control of actuator
In Control	Cascade is in control of actuator output
Active/Not Spd Ctrl	Cascade is active but Speed PID is not in control of actuator
Active w/Rmt Setpt	Cascade is active but Speed PID is not in control, Setpt is in remote control
In Ctrl w/Rmt Setpt	Cascade is in control, Speed PID is in control, Setpt is in remote control

Table 5-10. Cascade Control Messages

The following Cascade control indications are available through the Modbus links: Cascade is Enabled, Cascade is Active, Cascade is In Control, Cascade is Inhibited, and the Cascade Input Failed Alarm. In addition to these indications the Cascade Setpoint, Cascade Input, and Cascade PID Output analog values are also available.

Relay indications can be programmed to indicate Cascade Control Active, and Cascade Control Enabled.

Remote Cascade Setpoint

The Cascade control setpoint can be remotely positioned by an analog input (if programmed). The Remote Cascade Setpoint input can be enabled by pressing the front panel YES key from the Remote Cascade Status screen (screen 3), closing the Remote Cascade Setpoint Enable/Disable contact (if programmed), or selecting Remote Cascade Enable from either Modbus communications link. Remote Cascade Setpoint input is disabled by pressing the front panel NO key from the Remote Cascade Status screen (screen 3), opening the Remote Cascade Enable/Disable contact (if programmed), or selecting Remote Cascade Disable from either Modbus communications link. See Table 5-11 for all possible Remote Cascade control messages.

Message 4	Meaning
Disabled	Remote is not selected
Inhibited	Remote is inhibited and cannot be enabled
Enabled	Remote is enabled but not in control of the Setpt
Active	Remote is in control of the Setpt but not in control of the actuator output
In Control	Remote is in control of the Setpt and in control of the actuator output

Table 5-11. Remote Cascade Messages

The remote cascade control indications shown in Table 5-11 are available through the Modbus links: Remote Cascade is Enabled, Remote Cascade is Active, Remote Cascade is In Control, Remote Cascade is Inhibited, and Remote Cascade Input Failed Alarm. In addition to these indications, the Remote Cascade Input Setpoint is also available.

Relay indications can be programmed to indicate Remote Cascade Control Active and Remote Cascade Control Enabled status'.

Alarms

The ALARM key is always active in the RUN mode. Figure 5-16 shows the screen that appears when this key is pressed. If there are no alarms detected, the screen will display the 'Alarms Cleared' message. When an alarm is detected, the Alarm relay is energized and the front panel Alarm key illuminates. In addition, the screen will automatically "jump" to the ALARM screen (as defaulted in the Service mode) and display the alarm condition.

Table 5-12 lists all the potential alarm conditions and their cause. If more than one alarm condition is present, pressing the Down Arrow key will scroll through all active alarms. To view the most recent alarm, select the ALARM key. To clear any alarms that are no longer present, press the front panel RESET key, close the Reset contact input, or select Reset from either Modbus communications link.



Figure 5-16. ALARM Screen

Alarm Messages	Meaning
Speed Probe #1 Failed	Speed probe #1 failure—(< Failed Speed Level or 1 Vrms)
Speed Probe #2 Failed	Speed probe #2 failure—(< Failed Speed Level or 1 Vrms)
Cascade Input Fld	Cascade analog input failure detected (> 22 mA or < 2 mA)
Aux Input Fld	Auxiliary analog input failure detected (> 22 mA or < 2 mA)
KW Input Failed	KW analog input failure detected (> 22 mA or < 2 mA)
FSP Input Failed	FSP analog input failure detected (> 22 mA or < 2 mA)
Remote Spd Input Failed	Remote Speed Setpt analog input failure (> 22 mA or < 2 mA)
Remote Casc Input Fld	Remote Cascade Setpt analog input failure (> 22 mA or < 2 mA)
Remote Aux Input Fld	Remote Aux Setpt analog input failure (> 22 mA or < 2 mA)
Load Share Input Fld	Load Share analog input failure detected (> 22 mA or < 2 mA)
Act #1 Fault	Actuator #1 fault detected (an open or short circuit was sensed)
Act #2 Fault	Actuator #2 fault detected (an open or short circuit was sensed)
Start Perm Not Closed	Run was selected while the Start Perm contact in was not closed
Comm Link #1 Failed	Modbus com link #1 was detected as failed—time out error
Comm Link #2 Failed	Modbus com link #2 was detected as failed—time out error
Turbine Trip	Turbine is tripped alarm indication
Overspeed	Turbine overspeed alarm
Tie Breaker Opened	Utility Tie breaker was opened after it was closed
Gen Breaker Opened	Generator breaker was opened after it was closed
Tie Brkr Open/No Casc	Utility Tie breaker was opened when Cascade was active
Gen Brkr Open/No Casc	Generator breaker was opened when Cascade was active
Tie Brkr Open/No Remote	Util. Tie breaker was opened when Remote Spd Setpt was active
Gen Brkr Open/No Remote	Generator breaker was opened when Remote Spd Setpt was active
Tie Brkr Open/No Aux	Utility Tie breaker was opened when Auxiliary was active
Gen Brkr Open/No Aux	Generator breaker was opened when Auxiliary was active
Alarms Cleared	All alarms are cleared—no alarms are present

Table 5-12. Alarm Messages

Each individual alarm condition is available through the Modbus links to monitor the control status. A common alarm indication is also provided.

Relay indications can be programmed to indicate a 505 Common Alarm, in addition to the dedicated Alarm Relay output.

Trips

Figure 6-17 shows the screen that appears when there is a trip condition. The cause of the last trip can be seen under the CONT key (screen 2). Table 5-13 lists all the potential trip conditions and their cause.

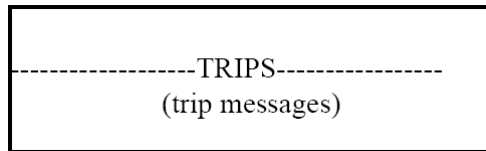

Figure 5-17. TRIP Screen

Message 6	Meaning
External Trip Input	External Trip contact input was opened
External Trip 2	External Trip #2 contact input was opened
External Trip 3	External Trip #3 contact input was opened
External Trip 4	External Trip #4 contact input was opened
External Trip 5	External Trip #5 contact input was opened
Emer Shutdown Button	Emergency Shutdown on the 505 front panel was pressed
Overspeed	Turbine overspeed was sensed
All Speed Probes Failed	Loss of all speed probes was sensed
Actuator #1 Fault	Actuator #1 fault detected (an open or short circuit was sensed)
Actuator #2 Fault	Actuator #2 fault detected (an open or short circuit was sensed)
Aux Input Failed	Aux analog input failure detected (> 22 mA or < 2 mA)
Comm Link #1 Trip	Modbus #1 communication link trip was commanded
Comm Link #2 Trip	Modbus #2 communication link trip was commanded
KW Input Failed	KW analog input failure detected (> 22 mA or < 2 mA)
Tie Breaker Opened	Utility tie breaker was opened after it was closed
Generator Breaker Open	Generator breaker was opened after it was closed
Power Up Trip	505 lost power and CPU was reset or the Program mode was exited
Shutdown Complete	Controlled shutdown was performed and completed

Table 5-13. Trip Messages

Each individual trip condition is available through the Modbus links to monitor the control status. A common trip indication is also provided.

Relay indications can be programmed to indicate a 505 Shutdown Condition (energizes for a shutdown condition) or a Trip Relay (de-energizes for a shutdown/trip), in addition to the dedicated Emergency Trip Relay output.

Speed, Cascade, and Auxiliary Dynamics Adjustments

Dynamic control values are programmed in the program mode and adjusted in the RUN mode. While in the run mode, pressing the DYN key calls up the dynamic adjustments of the parameter in control. The Proportional and Integral Gain dynamic adjustments are available under their respective keys (SPEED, CAS, & AUX). The Derivative term adjustments are made in the Service Mode—see volume 2). To adjust the gain settings, the @ symbol must be on the display line containing the asterisk/gain value to tune. The @ symbol is moved using the SELECT key. The ADJUST UP and DOWN keys can then be used to adjust the function on the line with the @ symbol.

The Speed, Cascade and Auxiliary controls are PID controllers. The response of each control loop can be adjusted by selecting the dynamics mode as described above. Proportional gain, integral gain (stability), and DR (derivative ratio) are the adjustable and interacting parameters used to match the response of the control loop with the response of the system. They correspond to the P (proportional), I (integral), and D (derivative) terms, and are displayed by the 505 as follows:

P = Proportional gain (%)

I = Integral gain (%)

D = Derivative (determined by DR and I)

If an older type 505 is being replaced by a new 505, the “P & D” terms will be the same, however, the “I” term should be reduced by a factor of 10 from the old 505’s reset value to achieve the same control response.

Tuning P & I Gains

Proportional gain must be tuned to best respond to a system transient or step change. If system response is not known, a typical starting value is 5%. If proportional gain is set too high the control will appear to be overly sensitive, and may oscillate with a cycle time of less than 1 second.

Integral gain must be tuned gain for best control at steady state. If system response is not known a typical starting value is 5%. If the integral gain is set too high the control may hunt or oscillate at cycles times of over 1 second.

For best response the proportional gain and integral gain should be as high as possible. To obtain a faster transient response, slowly increase the proportional gain setting until the actuator or final driver output begins to oscillate or waver. Then adjust the integral gain as necessary to stabilize the output. If stability cannot be obtained with the integral gain adjustment, reduce the proportional gain setting.

A well tuned system, when given a step change, should slightly overshoot the control point then come into control.

A PID control loop's gain is a combination of all the gains in the loop. The loop's total gain includes actuator gain, valve gain, and valve linkage gain, transducer gain, internal turbine gains, and the 505's adjustable gains. If the accumulated mechanical gain (actuators, valves, valve linkage, etc.) is very high, the 505's gain must be very low to be added to the system gain required for system stability.

In cases where a small change in the 505's output results in a large speed or load change (high mechanical gain) it may not be possible to take the 505's gains low enough to reach stable operation. In those cases the mechanical interface (actuator, linkage, servo, valve rack) design and/or calibration should be reviewed and changed to achieve a gain of one where 0-100% 505 output corresponds to 0- 100% valve travel.

Dual Dynamics (Speed/Load)

The Speed PID has two sets of dynamics, On-Line and Off-Line; each include Proportional Gain, Integral Gain, and Derivative Ratio (DR) variables. There are three cases that determine when the dynamics switch between On-Line and Off-Line:

- A "Select On-Line Dynamics" contact input is programmed
- Unit is driving a generator
- Unit is driving a mechanical drive (not a generator)

If a contact input is programmed to "Select On-Line Dynamics", it has priority regardless of the driven device. When the contact is closed, On-Line dynamics are selected; when open, Off-Line dynamics are selected.

If the unit is driving a generator and no "Select On-Line Dynamics" contact input is programmed, the Speed Off-Line dynamics are used by the Speed PID when the generator or utility tie breaker contacts are open. The speed On-Line dynamics are used by the speed PID when the generator and utility tie breaker contacts are closed. If the speed dynamics select contact is programmed, the generator and utility tie contacts do not effect the dynamics selection.

If the unit is not driving a generator and no "Select On-Line Dynamics" contact input is programmed, the Speed Off-Line dynamic settings are used when the turbine speed is below minimum governor speed; On-Line dynamics are used if the turbine speed is above minimum governor speed. If the speed dynamics select contact is programmed, the turbine speed does not effect the dynamics selection.

A relay can be programmed to indicate that the On-Line Dynamics mode is selected.

Cascade/Auxiliary Droop

The Cascade and Auxiliary controllers can be programmed to use droop for control loop stability. If the parameter being controlled (Cascade or Auxiliary) is also being controlled by another device (letdown station, boiler, or other turbine), droop is typically required for control loop stability. If required, no less than 5% droop is recommend for stable operation.

Tuning Derivative

The value of the Derivative Ratio (DR) term can range from 0.01 to 100. If unsure of the correct value, set the Speed control's DR term to 5% and the Aux & Cascade controllers' DR terms to 100%. In order to simplify adjustment of the dynamics, adjusting the integral gain value sets both the I and D terms of the PID controller. The DR term establishes the degree of effect the integral gain value has on the "D" term, and changes the configuration of a controller from input rate sensitive (input dominant) to feedback rate sensitive (feedback dominant) and vice versa.

Another possible use of the DR adjustment is to reconfigure the controller from a PID to a PI controller. This is done by adjusting the DR term to its upper or lower limits, depending on whether an input or feedback dominant controller is desired.

- A DR setting of 1 to 100 selects feedback dominant mode.
- A DR setting of .01 to 1 selects input dominant mode.
- A DR setting of .01 or 100 selects a PI only controller, input and feedback dominant respectively.

The change from one of these configurations to the other may have no effect during normal operation, however, it can cause great differences in response when the governor is coming into control. (at startup, during a full load change, or during transfer of control from another channel).

An input dominant controller is more sensitive to the change-of-rate of its input (Speed, Cascade in or Auxiliary in), and can therefore prevent overshoot of the setpoint better than a feedback dominant controller. Although this response is desirable during a startup or full load rejections, it can cause excessive control motions in some systems where a smooth transition response is desired.

A controller configured as feedback dominant is more sensitive to the change-of-rate of its feedback (LSS). A feedback dominant controller has the ability to limit the rate of change of the LSS bus when a controller is near its setpoint but is not yet in control. This limiting of the LSS bus allows a feedback dominant controller to make smoother control transitions than an input dominant controller.

Tuning Example

If the system is unstable, make sure the governor is the cause. This can be checked by closing the valve limiter until it has control of the actuator output. If the governor is causing the oscillation, time the oscillation cycle time. A rule-of-thumb is, if the system's oscillation cycle time is less than 1 second reduce the Proportional gain term. A rule-of-thumb is, if the system's oscillation cycle time is greater the 1 second reduce the Integral gain term (proportional gain may need to be increased also).

On an initial startup with the 505, all PID dynamic gain terms will require adjustment to match the respective PID's response to that of its control loop. There are multiple dynamic tuning methods available that can be used with the 505's PIDs to assist in determining the gain terms that provide optimum control loop response times (Ziegler Nichols, etc.). The following method is a simplified version of other tuning methods, and can be used to achieve PID gain values that are close to optimum:

1. Increase Derivative Ratio (DR) to 100 (This is the default setting).
2. Reduce integral gain to minimum.
3. Increase proportional gain until system just starts to oscillate.
4. Record the system gain (G) and oscillation period (T).
5. Set the dynamics as follows:
 - For PID control set the proportional gain= $0.60 \cdot G$; integral gain= $20/T$; DR=5
 - For PI control set the proportional gain= $0.45 \cdot G$; integral gain= $12/T$; DR=100

This method of tuning will get the gain settings close, they can be fine-tuned from this point. Figure 5-18 shows the typical response to a load change when the dynamics are optimally adjusted.

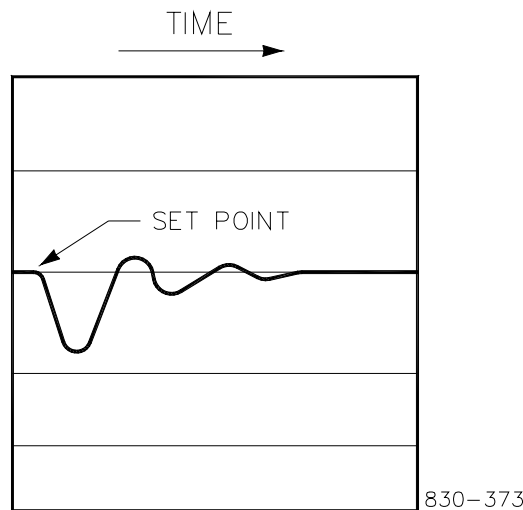

Figure 5-18. Typical Response to Load Change



NOTE

For additional information on PID settings, refer to Volume 2.

Chapter 6. Communications

Modbus[®] * Communications

The 505 control can communicate with plant distributed control systems and/or CRT based operator control panels through two Modbus[®] * communication ports. These ports support RS-232, RS-422, RS-485 communications using ASCII or RTU MODBUS transmission protocols. Modbus utilizes a master/slave protocol. This protocol determines how a communication network's master and slave devices establish and break contact, how a sender is identified, how messages are exchanged, and how errors are detected.

*—Modbus is a trademark of Modicon, Inc.

Monitor Only

The two Modbus communication ports, as defaulted from the factory, are not programmed. Although these ports are not programmed they continue to update all information to all registers. This allows the 505 to be monitored but not controlled from an external device. By simply connecting a monitoring device, configured to communicate through Modbus, and to the 505's defaulted protocol settings (parity, stop bits, etc.), this device can be used to monitor all the 505's controlling parameters, modes, etc. without effecting control.

To use a 505 port to only monitor 505 parameters and operational modes or not use the port at all (Boolean and analog write commands are ignored), program the port's 'Use Modbus Port' setting to 'NO'.

Monitor and Control

Once a Modbus port is configured within the 505's Program Mode, the 505 will accept RUN mode commands from an external network master device (DCS, etc.). This allows a Modbus compatible device to monitor and perform all 505 RUN mode parameters and commands except for the Overspeed Test enable, On-Line/Off-Line Dynamics select, and Override Failed Speed Signal commands.

Both Modbus ports are independent of each other, and can be used simultaneously. The last command given between the two ports has priority or is the mode or function selected.

To use a 505 Modbus port to monitor and operate the 505 through, program the port's 'Use Modbus Port' setting to 'YES'.

Modbus Communication

The 505 control supports two Modbus transmission modes. A mode defines the individual units of information within a message and the numbering system used to transmit the data. Only one mode per Modbus network is allowed. The supported modes are ASCII (American Standard Code for Information Interchange), and RTU (Remote Terminal Unit). These modes are defined in the following table.

Characteristic	ASCII	RTU
Coding System	hexadecimal (uses ASCII printable binary characters: 0-9,A-F)	8-bit binary
Start Bits	1	1
Data Bits per Char	7	8
Parity	even, odd or none	even, odd or none
Stop Bits	1, 1.5, or 2	1, 1.5, or 2
Baud Rate	110, 300, 600, 1200 1800,2400, 4800, 9600 19200, 38400, or 57600	110,300, 600, 1200 1800, 2400, 4800, 9600 19200, 38400, or 57600
Error Checking	LRC(Longitudinal Redundancy Check)	CRC(Cyclical Redundancy Check)

Table 6-1. ASCII vs RTU Modbus

In the RTU mode, data is sent in 8-bit binary characters and transmitted in a continuous stream. In the ASCII mode, each binary character is divided into two 4-bit parts (high order and low order), changed to be represented by a hexadecimal equivalent, then transmitted, with breaks of up to 1 second possible. Because of these differences, data transmission with the ASCII mode is typically slower (see Figure 6-1 below).

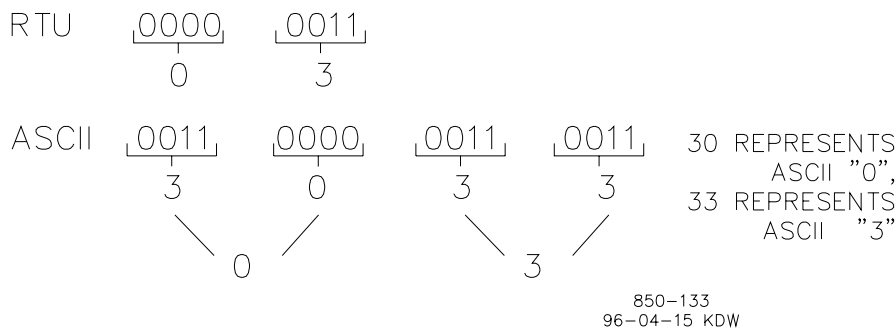

Figure 6-1. ASCII/RTU Representation of 3

The Modbus protocol allows one master and up to 247 slaves on a common network. Each slave is assigned a fixed, unique device address in the range of 1 to 247. With the Modbus protocol, only the network master can initiate a transaction. A transaction consists of a request from the master to a slave unit and the slave's response. The protocol and Modbus device number are set in the Program Mode and can be adjusted in the Service Mode, if required.

The 505 control is programmed to function as a slave unit only. As a slave unit, the 505 will only respond to a transaction request by a master device. The 505 can directly communicate with a DCS or other Modbus supporting device on a single communications link, or through a multi-dropped network. If multi-dropping is used, up to 246 devices (505s or other customer devices) can be connected to one Master device on a single network. The control address is programmed under the 505's communications block and can be changed in the service mode, if needed.

Each message to or from a master has a defined structure called the message "frame". A frame consists of the slave device address, a code defining the requested data, and error checking information. See Figure 6-2.

	BEGINNING OF FRAME	SLAVE ADDRESS	FUNCTION CODE	DATA	ERROR CHECK CODE	END OF FRAME
ASCII	:	2 CHARS 8 BITS	2 CHARS 8 BITS	4 BITS DATA PER CHAR	2 CHAR 8 BITS	CR LF
RTU	3-CHAR DEAD TIME	1 CHAR 8 BITS	1 CHAR 8 BITS	8 BITS DATA PER CHAR	2 CHAR 16 BITS	3 CHAR DEAD TIME

855-382
93-09-27 DAR

Figure 6-2. Modbus Frame Definition

The Modbus function code tells the addressed slaves what function to perform. The following table lists the function codes supported by this control.

Modbus Function Codes

Code	Definition	Reference Address
01	Read Digital Outputs (Raise/Lower and Enable/Disable Commands)	0XXXX
02	Read Digital Inputs (Status Indications/Alarms and Trips)	1XXXX
03	Read Analog Outputs	4XXXX
04	Read Analog Inputs (Speed, Setpt, etc.)	3XXXX
05	Write Single Discrete Output (Raise/Lower and Enable/Disable Commands)	0XXXX
06	Write Single Register (Enter Setpt Directly)	4XXXX
08	Loopback Diagnostic Test (Subfunction 0 only)	N/A
15	Write Digital Outputs	0XXXX
16	Write Analog Outputs	4XXXX

Table 6-2. Modbus Function Codes

When a Modbus message is received, it is checked for any errors or invalid data. If there is invalid data in the message, an error code is sent back to the master and the control issues an alarm message. The error codes are defined in the following table. The exception error status and respective error codes can be viewed in the Service mode under PORT # SETTINGS, where # is the number of the port (1 or 2).

If the control has not received a message for the configured time-out period, the control will alarm with an error message, but no message is sent to the master. This time-out is defaulted to 2 seconds and only applies to units using both monitor and control (adjustable in the Service Mode).

Modbus Slave Exception Error Codes

Error Code	Error Message	Code Sent To Master	Description
0	No Error	0	No Error
1	Bad Modbus function	1	The specified function is not supported for this control.
2	Bad Modbus data address	2	The Modbus value addressed is not valid for this control.
3	Bad Modbus data value	3	Too many values requested or the on/off indicator in function code 5 is invalid.
9	Bad Modbus checksum	None	Message checksum did not match.
10	Bad Modbus message	None	Message could not be decoded.
N/A	Lost Modbus link	None	No messages received for the configured time-out period

Table 6-3. Modbus Error Codes

Port Adjustments

Before the 505 will communicate with the master device, the communication parameters must be verified. These values are set in the Program Mode and can be adjusted, if required, from the Service Mode.

Modbus Communication Port Adjustments

Parameter	Adjustment Range
Baud Rate	110 TO 57600
Parity	NONE, ODD or EVEN
Stop Bits	1 TO 2
Driver	RS232, RS422, or RS485

505 Control Modbus Addresses

The Modbus communication ports in the 505 control are programmed for unique Modbus addresses. A complete listing of these addresses for your application is located at the end of this section in the manual. The Modbus address listing consists of Boolean Writes, Boolean Reads, Analog Reads, and Analog Writes. The Boolean reads and writes are also referred to as input and holding coils. The analog reads and writes are also referred to as input registers and holding registers.

All values that can be addressed by Modbus are considered to be discrete and numeric. The discrete values are a 1 bit binary, on or off value and the numerics are 16 bit values. Discrete values are sometimes referred to as coils or digitals and numerics are referred to as registers or analogs. All read/write registers are interpreted by the 505 as signed 16 bit integer values. Since Modbus can only handle integers, values that require a decimal point in the Modbus Master Device are multiplied by a scaling constant before being sent by 505. See Tables 6-7 & 6-8 for defaulted communication constants and ranges.

The maximum number of discretets and registers that can be transmitted in one packet is dependent on each implementation of Modbus. The following table defines these limits.

Mode Of Transmission	Max Discretes	Max Registers
ASCII	944	59
RTU	1188	118

Table 6-4. Maximum Modbus Discrete and Analog Values

Boolean Writes (Holding Coils)

Holding coils are logical signals that are both readable from and writable to the 505 control. An example of a Boolean write value would be raise or lower commands. A logical true denoted by the value 1 will cause the command listed in the description to be executed. For example, if a 1 is written to address 0:0010 and this corresponded to a speed raise command, the manual speed setpoint will increase until a 0 is written to address 0:0010. The 505 control supports function codes 1, 5, and 15. These correspond to reading selected holding coils, writing to a single holding coil, and writing to multiple holding coils, respectively. The holding coils available are listed in Table 6-5.

Boolean Reads (Input Coils)

Input coils are logical signals that are readable from, but not writable to, the 505 control. An example of an Boolean read value would be a turbine trip status indication. The input coil will have the value 1 if the statement in the description column is true and a 0 if false. The '1:' term in the address identifies an input coil. The 505 control supports Modbus function code 2, which involves reading selected input coils. The input coils available are listed in Table 6-6.

Analog Reads (Input Registers)

Input registers are analog values that are readable from, but not writable to, the 505 control. An example of an analog read value would be turbine speed. The values of the input registers are stored internal to the control as floating point numbers representing engineering units (kPa or rpm). The values that are transmitted are integer values ranging from -32767 to +32767. Since Modbus can only handle integers, values that have a decimal point are multiplied by a constant before being sent by Modbus. For example, these input registers may be listed as the Modbus value 'x100' or 'x10' under the description heading to denote the value is multiplied by a scaling constant. This will allow transmission of decimal parts of a unit if this is necessary for better resolution.

See the 505 Service mode for defaulted communication constants and ranges. The 505 control supports Modbus function code 4, which involves reading selected input registers. The input registers available are listed in Table 6-7.

Analog Writes (Holding Registers)

Holding registers are analog values that are writable to the 505 control. These values can also be read from by a device performing error checking. An example of an analog write value would be a direct speed setpoint value as opposed to raise and lower commands. The value of the holding registers are also stored in the control as numbers representing engineering units (psi or rpm). The 505 control supports Modbus function codes 3, 6, and 16. These correspond to reading selected holding registers, writing to a single holding register, and writing to multiple holding registers, respectively. The holding registers available are listed in Table 6-8.

The following tables give the address and description of all Boolean and analog, reads and writes:

Addr	Description	Addr	Description
0.0001	Emergency Shutdown	0.0041	Spare
0.0002	Emergency Shutdown Acknowledge	0.0042	Modbus Alarm Acknowledge
0.0003	Controlled Shutdown	0:0043	Turn On/Energize Modbus Relay 1
0.0004	Abort Controlled Shutdown	0:0044	Turn Off/De-Energize Modbus Relay 1
0.0005	System Reset	0:0045	Turn On/Energize Modbus Relay 2
0.0006	Start/Run	0:0046	Turn Off/De-Energize Modbus Relay 2
0.0007	Manual Open Valve Limiter	0:0047	Turn On/Energize Modbus Relay 3
0.0008	Manual Close Valve Limiter	0:0048	Turn Off/De-Energize Modbus Relay 3
0.0009	Lower Speed Setpoint	0:0049	Turn On/Energize Modbus Relay 4
0.0010	Raise Speed Setpoint	0:0050	Turn Off/De-Energize Modbus Relay 4
0.0011	Go To Rated (Idle/Rated)	0:0051	Turn On/Energize Modbus Relay 5
0.0012	Go To Idle (Idle/Rated)	0:0052	Turn Off/De-Energize Modbus Relay 5
0.0013	Halt Auto Start Sequence	0:0053	Turn On/Energize Modbus Relay 6
0.0014	Continue Auto Start Sequence	0:0054	Turn Off/De-Energize Modbus Relay 6
0.0015	Enable Remote Speed Setpt Control	0:0055	Spare
0.0016	Disable Rmt Speed Setpt Control	0:0056	Spare
0.0017	Go To Modbus Entered Speed Setpt	0:0057	Spare
0.0018	Spare	0:0058	Spare
0.0019	Arm Frequency Control	0:0059	Spare
0.0020	Disarm Frequency Control	0:0060	Spare
0.0021	Sync Enable	0:0061	Spare
0.0022	Sync Disable	0:0062	Spare
0.0023	Enable Cascade Control	0:0063	Spare
0.0024	Disable Cascade Control	0:0064	Spare
0.0025	Lower Cascade Setpoint	0:0065	Spare
0.0026	Raise Cascade Setpoint	0:0066	Spare
0.0027	Enable Rmt Cascade Setpt Control	0:0067	Spare
0.0028	Disable Rmt Cascade Setpt Control	0:0068	Spare
0.0029	Go To Modbus Entered Cascade Setpoint	0:0069	Spare
0.0030	Spare	0:0070	Spare
0.0031	Enable Aux control (Aux controller only)	0:0071	Spare
0.0032	Disable Aux Control (Aux controller only)	0:0072	Spare
0.0033	Lower Aux setpoint	0:0073	Spare
0.0034	Raise Aux Setpoint	0:0074	Spare
0.0035	Enable Rmt Aux Setpt Control	0:0075	Momentarily Energize Modbus Relay #1
0.0036	Disable Rmt Aux Setpt Control	0:0076	Momentarily Energize Modbus Relay #2
0.0037	GoTo Modbus Entered Aux Setpt	0:0077	Momentarily Energize Modbus Relay #3
0.0038	Spare	0:0078	Momentarily Energize Modbus Relay #4
0.0039	Select Remote Ctrl (Remote/Local)	0:0079	Momentarily Energize Modbus Relay #5
0.0040	Select Local Ctrl (Remote/Local)	0:0080	Momentarily Energize Modbus Relay #6

Table 6-5. Boolean Write Addresses

Addr	Description	Addr	Description
1:0001	Alarm—MPU #1 Failed	1:0043	Trip—Overspeed Trip
1:0002	Alarm—MPU #2 Failed	1:0044	Trip—Loss of Speed Signals
1:0003	Alarm—Cascade Input Failed	1:0045	Trip—Actuator # 1 Fault
1:0004	Alarm—Aux Input Failed	1:0046	Trip—Actuator # 2 Fault
1:0005	Alarm—KW Input Failed	1:0047	Trip—Aux Input Failed
1:0006	Alarm—Sync Input Failed	1:0048	Trip—External Trip 2
1:0007	Alarm—First Stage Press Input Failed	1:0049	Trip—External Trip 3
1:0008	Alarm—Remote Speed Input Failed	1:0050	Trip—Modbus Link #1 Trip
1:0009	Alarm—Remote Cascade Input Failed	1:0051	Trip—Modbus Link #2 Trip
1:0010	Alarm—Remote Aux Input Failed	1:0052	Trip—spare
1:0011	Alarm—Loadshare Input Failed	1:0053	Trip—Tie Breaker Open
1:0012	Alarm—Actuator #1 Failed	1:0054	Trip—Gen Breaker Open
1:0013	Alarm—Actuator #2 Failed	1:0055	Trip—Power up
1:0014	Alarm- Start Permissive Not Met	1:0056	Trip—Manual Stop
1:0015	Alarm—Communication Link #1 Failed	1:0057	Trip—External Trip 4
1:0016	Alarm—Communication Link #2 Failed	1:0058	Trip—External Trip 5
1:0017	Alarm—Generator Breaker Open	1:0059	Trip—spare
1:0018	Alarm—Turbine Trip	1:0060	Trip—spare
1:0019	Alarm—Tie Breaker Open	1:0061	Trip—spare
1:0020	Alarm—Overspeed Alarm	1:0062	Trip—spare
1:0021	Alarm—Tie Breaker Open/No Aux	1:0063	Trip—spare
1:0022	Alarm—Gen Breaker Open/No Aux	1:0064	Shutdown Exists (Trip Indication)
1:0023	Alarm—Tie Breaker Open/No Casc	1:0065	ESD Acknowledge Enable
1:0024	Alarm—Gen Breaker Open/No Casc	1:0066	Moving to Min Setpoint
1:0025	Alarm—Tie Breaker Open/No Remote	1:0067	Idle/Rated—Ramping to Idle
1:0026	Alarm—Gen Breaker Open/No Remote	1:0068	Idle/Rated—At Idle
1:0027	Alarm—Stuck in Critical Alarm	1:0069	Idle/Rated—Ramping to Rated
1:0028	Alarm—spare	1:0070	Idle Rated—At Rated
1:0029	Alarm—spare	1:0071	Auto Seq—Setpt at Lo Idle
1:0030	Alarm—spare	1:0072	Auto Seq—Ramping to High Idle
1:0031	Alarm—spare	1:0073	Auto Seq—Setpt at High Idle
1:0032	Alarm—spare	1:0074	Auto Seq—Ramping to Rated
1:0033	Alarm—spare	1:0075	Auto Seq—At Rated
1:0034	Alarm—spare	1:0076	Speed PID In Control
1:0035	Alarm—spare	1:0077	Speed Sensor 1 Failed Override ON
1:0036	Alarm—spare	1:0078	Speed Sensor 2 Failed Override ON
1:0037	Alarm—spare	1:0079	Overspeed Test Permissive
1:0038	OpView Alarm latch	1:0080	Overspeed Test In Progress
1:0039	Alarm Acknowledge	1:0081	Speed At or above Min Gov
1:0040	Alarm Exists (Common Alarm Indication)	1:0082	Turbine In Critical Speed Band
1:0041	Trip—External Trip	1:0083	Remote Speed Setpt Is Enabled
1:0042	Trip—ESD Button	1:0084	Remote Speed Setpt Is Active
1:0085	Remote Speed Setpt Is In Control	1:0129	Spare
1:0086	Remote Speed Setpt Is Inhibited	1:0130	Spare
1:0087	Spare	1:0131	Spare
1:0088	Spare	1:0132	Spare
1:0089	Spare	1:0133	Spare
1:0090	Generator Breaker Closed	1:0134	Spare
1:0091	Utility Tie Breaker Closed	1:0135	Spare
1:0092	Synchronizing Rate Selected	1:0136	Spare
1:0093	Synchronizing Is Enabled	1:0137	Valve Limiter Is Open
1:0094	Sync or Load Share Is In Control	1:0138	Valve Limiter Is Closed
1:0095	Sync/Load Share Is Inhibited	1:0139	Valve Limiter In Control
1:0096	Spare	1:0140	Remote/Local-Remote Selected
1:0097	Frequency Control Armed	1:0141	Remote/Local—Modbus #1 Active
1:0098	Frequency Control	1:0142	Start Permissive
1:0099	Spare	1:0143	Controlled Stop In Progress
1:0100	Cascade Is Enabled	1:0144	Spare
1:0101	Cascade Is Active	1:0145	Spare

1:0102	Cascade Is In Control	1:0146	Spare
1:0103	Cascade Is Inhibited	1:0147	Spare
1:0104	Rmt Cascade Is Enabled	1:0148	Spare
1:0105	Rmt Cascade Is Active	1:0149	Spare
1:0106	Rmt Cascade Is In Control	1:0150	Spare
1:0107	Rmt Cascade Is Inhibited	1:0151	Shutdown Relay Energized
1:0108	Spare	1:0152	Alarm Relay Energized
1:0109	Auxiliary Is Enabled	1:0153	Relay 1 Energized
1:0110	Auxiliary Is Active	1:0154	Relay 2 Energized
1:0111	Auxiliary Is In Control	1:0155	Relay 3 Energized
1:0112	Aux Active/Not Limiting	1:0156	Relay 4 Energized
1:0113	Aux Active/Not In Control	1:0157	Relay 5 Energized
1:0114	Auxiliary is Inhibited	1:0158	Relay 6 Energized
1:0115	Remote Aux Is Enabled	1:0159	ESD Contact Input Closed
1:0116	Remote Aux Is Active	1:0160	Reset Contact Input Closed
1:0117	Rmt Aux Is In Control	1:0161	Raise Speed Contact Input Closed
1:0118	Rmt Aux Is Inhibited	1:0162	Lower Speed Contact Input Closed
1:0119	Spare	1:0163	Contact In 1 Closed
1:0120	Spare	1:0164	Contact In 2 Closed
1:0121	Spare	1:0165	Contact In 3 Closed
1:0122	Spare	1:0166	Contact In 4 Closed
1:0123	Spare	1:0167	Contact In 5 Closed
1:0124	Spare	1:0168	Contact In 6 Closed
1:0125	Spare	1:0169	Contact In 7 Closed
1:0126	Spare	1:0170	Contact In 8 Closed
1:0127	Spare	1:0171	Contact In 9 Closed
1:0128	Spare	1:0172	Contact In 10 Closed
1:0173	Contact In 11 Closed	1:0187	Gen Set Configured
1:0174	Contact In 12 Closed	1:0188	Cascade Control Configured
1:0175	Aux Limiter Configured	1:0189	Remote Cascade Configured
1:0176	Sync Function Configured	1:0190	Aux Control Configured
1:0177	ESD Control Configured	1:0191	Remote Aux Configured
1:0178	Manual Start Configured	1:0192	Enables Mod1 in local
1:0179	Auto Start Configured	1:0193	Start Permissive Configured
1:0180	Semi-Auto Start Configured	1:0194	Frequency Arm/Disarm Configured
1:0181	Idle/Rated Start Configured	1:0195	Frequency Control Configured
1:0182	Auto Start Sequence Configured	1:0196	MPU 2 Configured
1:0183	First Stage Pressure Configured	1:0197	Local/Remote Configured
1:0184	Remote Control Configured	1:0198	Local Trip Enabled
1:0185	Loadsharing Configured	1:0199	Casc Tracking Configured
1:0186	Actuator 2 Configured	1:0200	KW Signal OK

Table 6-6. Boolean Read Addresses

Addr	Description	Units	Multiplier
3:0001	Control Parameter *	none	none
3:0002	Speed Sensor #1 Input	rpm	none
3:0003	Speed Sensor #2 Input	rpm	none
3:0004	Actual Turbine Speed	rpm	none
3:0005	Actual Speed (%)	%	100
3:0006	Speed Setpoint (%)	%	100
3:0007	Speed Setpoint	rpm	none
3:0008	Speed Droop Setpoint	rpm	none
3:0009	Speed Droop	%	100
3:0010	Speed PID Output	%	100
3:0011	Min Governor Speed Setpoint	rpm	none
3:0012	Highest Speed Reached	rpm	none
3:0013	Idle/Rated—Idle Speed	rpm	none
3:0014	Idle/Rated—Rated Speed	rpm	none
3:0015	Auto Seq-Low Idle Speed Setpt	rpm	none
3:0016	Auto Seq-Low Idle Delay Time	min	100

Addr	Description	Units	Multiplier
3:0017	Auto Seq-Time Left At Low Idle	min	100
3:0018	Auto Seq-Low Idle to High Idle Rate	rpm/sec	none
3:0019	Auto Seq-High Idle Speed Setpoint	rpm	none
3:0020	Auto Seq-High Idle Delay Time	min	100
3:0021	Auto Seq-Time Remaining At High Idle	min	100
3:0022	Auto Seq-High Idle to Rated Rate	rpm/sec	none
3:0023	Auto Seq—Rated Speed Setpt	rpm	none
3:0024	Auto Seq—Run Time Hours	hrs	none
3:0025	Auto Seq—Hours Since Alarm	hrs	none
3:0026	Cascade Setpoint (Scaled)	Casc units	cascade scale factor
3:0027	Cascade PID Output	%	100
3:0028	Cascade Input (%)	%	100
3:0029	Cascade Setpoint (%)	%	100
3:0030	Cascade Scale Factor	none	none
3:0031	Cascade Input (Scaled)	Casc units	cascade scale factor
3:0032	Remote Cascade Input (Scaled)	Casc units	cascade scale factor
3:0033	Aux Setpoint (Scaled)	aux units	aux scale factor
3:0034	Aux PID Output	%	100
3:0035	Aux Input (%)	%	100
3:0036	Aux Setpoint (%)	%	100
3:0037	Aux Scale Factor	none	none
3:0038	Aux Input (Scaled)	aux units	aux scale factor
3:0039	Remote Aux Input (Scaled)	aux units	aux scale factor
3:0040	Remote Speed Setpoint Input	rpm	none
3:0041	FSP Scale Factor	none	none
3:0042	FSP Input (Scaled)	FSP units	FSP scale factor
3:0043	Loadshare Scale Factor	none	none
3:0044	Sync/Loadshare Input (Scaled)	rpm	ldshr scale factor
3:0045	KW Scale Factor	none	none
3:0046	KW Input (Scaled)	kW units	kW scale factor
3:0047	Vlv Limiter Setpt	%	100
3:0048	Actuator Demand	%	100
3:0049	Actuator 1 Demand	%	100
3:0050	Actuator 2 Demand	%	100
3:0051	Spare		
3:0052	Spare		
3:0053	Spare		
3:0054	Spare		
3:0055	Spare		
3:0056	Spare		
3:0057	Spare		
3:0058	Spare		
3:0059	Spare		
3:0060	Modbus Entered Speed Setpoint (fdbk)	rpm	none
3:0061	Modbus Entered Cascade Setpt (fdbk)	Casc units	Casc scale factor
3:0062	Modbus Entered Aux Setpt (fdbk)	Aux units	Aux scale factor
3:0063	Spare		
3:0064	Spare		
3:0065	Spare		
3:0066	Spare		
3:0067	Spare		
3:0068	Spare		
3:0069	Spare		
3:0070	Spare		
3:0071	Spare		
3:0072	Analog Input 1	%	100
3:0073	Analog Input 2	%	100
3:0074	Analog Input 3	%	100
3:0075	Analog Input 4	%	100
3:0076	Analog Input 5	%	100
3:0077	Analog Input 6	%	100
3:0078	Analog Output 1	mA	100
3:0079	Analog Output 2	mA	100
3:0080	Analog Output 3	mA	100
3:0081	Analog Output 4	mA	100

Addr	Description	Units	Multiplier
3:0082	Analog Output 5	mA	100
3:0083	Analog Output 6	mA	100
3:0084	Actuator #1 Output	mA	100
3:0085	Actuator #2 Output	mA	100
3:0086	Last Trip	none	none
3:0087	KW units (3 = MW, 4 = KW)	none	none
3:0088	Analog Input 1 Configuration *	none	none
3:0089	Analog Input 2 Configuration *	none	none
3:0090	Analog Input 3 Configuration *	none	none
3:0091	Analog Input 4 Configuration *	none	none
3:0092	Analog Input 5 Configuration *	none	none
3:0093	Analog Input 6 Configuration *	none	none
3:0094	Analog Output 1 Configuration *	none	none
3:0095	Analog Output 2 Configuration *	none	none
3:0096	Analog Output 3 Configuration *	none	none
3:0097	Analog Output 4 Configuration *	none	none
3:0098	Analog Output 5 Configuration *	none	none
3:0099	Analog Output 6 Configuration *	none	none
3:0100	Relay 1 Configuration *	none	none
3:0101	Relay 2 Configuration *	none	none
3:0102	Relay 3 Configuration *	none	none
3:0103	Relay 4 Configuration *	none	none
3:0104	Relay 5 Configuration *	none	none
3:0105	Relay 6 Configuration *	none	none
3:0106	Contact Input 1 Configuration *	none	none
3:0107	Contact Input 2 Configuration *	none	none
3:0108	Contact Input 3 Configuration *	none	none
3:0109	Contact Input 4 Configuration *	none	none
3:0110	Contact Input 5 Configuration *	none	none
3:0111	Contact Input 6 Configuration *	none	none
3:0112	Contact Input 7 Configuration *	none	none
3:0113	Contact Input 8 Configuration *	none	none
3:0114	Contact Input 9 Configuration *	none	none
3:0115	Contact Input 10 Configuration *	none	none
3:0116	Contact Input 11 Configuration *	none	none
3:0117	Contact Input 12 Configuration *	none	none
3:0118	Aux Units Configured *	none	none
3:0119	Cascade Units Configured *	none	none
3:0120	Spare		

* Look up table at end of section

Table 6-7. Analog Read Addresses

Addr	Description	Units	Multiplier
4:0001	Modbus Entered Speed Setpoint	rpm	none
4:0002	Modbus Entered Casc Setpoint	Casc units	Casc scale factor
4:0003	Modbus Entered Aux Setpoint	Aux units	Aux scale factor
4:0004	Spare		
4:0005	Spare		
4:0006	Spare		
4:0007	Spare		
4:0008	Spare		

Table 7-8. Analog Write Addresses

Last Turbine Trip Cause

The cause of the last turbine trip (address 3:0086) is an integer that represents the following cause:

Value	Description
1.	External Trip Input
2.	Emergency Shutdown Button (front panel push-button)
3.	Overspeed Trip
4.	All Speed Probes Failed
5.	Act #1 Fault
6.	Act #2 Fault
7.	Aux Input Failed
8.	External Trip 2
9.	External Trip 3
10.	Comm Link #1 Trip
11.	Comm Link #2 Trip
12.	KW Input Failed
13.	Utility Tie Breaker Opened
14.	Generator Breaker Opened
15.	Power up Shutdown
16.	Manual (controlled) Shutdown
17.	External Trip 4
18.	External Trip 5

Table 6-9. Last Turbine Trip Cause

505 Controlling Parameters

The controlling parameter status of the 505 uses an Analog Read register (3:0001) to identify the parameters that are in control. This variable follows what is displayed on the controlling parameter screen, under the 'CONT' key. The variable gives the current status of the control and is defined in the following table.

Value	Description
1.	Speed/Off—Line
2.	Speed/On—Line
3.	Remote/Speed
4.	Cascade/Speed
5.	Remote Cascade/Speed
6.	Frequency/Speed
7.	Load Share/Speed
8.	Synchronizing
9.	Auto Start Sequence
10.	Idle/Rated Start
11.	Semi Auto Start
12.	Auto Start
13.	Manual Start
14.	Ready to Start
15.	Start Perm Not Met
16.	Configuration Error
17.	Auxiliary
18.	Remote Auxiliary
19.	Valve Limiter
20.	Max Actuator
21.	Spare for future use
22.	Controlled Shutdown
23.	Shutdown

Table 6-10. Control Status

Analog Read addresses 3:0088—0093 give the configuration value of the analog inputs, one to six in order. The configuration for the analog inputs are defined in the table below.

Value	Description
1.	Remote Speed Setpt
2.	Synchronizing Input
3.	Sync/Load Share Input
4.	KW/Unit Load Input
5.	Cascade Input
6.	Remote Cascade Setpt
7.	Auxiliary Input
8.	Remote Aux Setpt
9.	First Stage Press Input
10.	(Not Used)

Table 6-11. Analog Input Configuration

Analog Read addresses 3:0094—0099 give the configuration value of the analog outputs, one to six in order. The configuration for the analog outputs are defined in the table below.

Value	Description
1.	Actual Speed
2.	Speed Setpoint
3.	Remote Speed Setpt
4.	Load Share Input
5.	Sync Input
6.	KW Input
7.	Cascade Input
8.	Cascade Setpoint
9.	Rmt Cascade Setpt
10.	Auxiliary Input
11.	Auxiliary Setpoint
12.	Rmt Auxiliary Setpt
13.	Valve Limiter Setpoint
14.	Actuator Demand Readout
15.	Actuator 1 Readout
16.	Actuator 2 Readout
17.	First Stg Press Input
18.	(Not Used)

Table 6-12. Analog Output Configuration

Analog Read addresses 3:0100—0105 give the configuration value of the relays, one to six in order. The configuration for the relays are defined in the table below.

Value	Description
Relay Configured As Level Switch	
0.	Under speed Switch
1.	Speed Level Switch
2.	Speed Setpoint Level Switch
3.	KW Level Switch
4.	Load Share Level Switch
5.	Cascade Level Switch
6.	Cascade Setpoint Level Switch
7.	Aux Level Switch
8.	Aux Setpoint Level Switch
9.	Actuator Demand Level Switch
10.	Act 1 Demand Level Switch
11.	Act 2 Demand Level Switch
12.	Valve Limiter Level Switch
13.	First Stage Pressure Level Switch
Relay Configured To Indicate State	
21.	Shutdown Condition
22.	Trip Relay (additional trip relay output)
23.	Alarm Condition
24.	Control Status OK
25.	Overspeed Trip
26.	Overspeed Test Enabled
27.	Speed PID in Control
28.	Remote Speed Setpt Enabled
29.	Remote Speed Setpt Active
30.	Underspeed Switch
31.	Auto Start Sequence Halted
32.	On-Line PID Dynamics Mode
33.	Local Control Mode
34.	Frequency Control Armed
35.	Frequency Control
36.	Sync Enabled
37.	Sync/Load Share Active
38.	Load Share Control
39.	Casc Control Enabled
40.	Cascade Control Active
41.	Remote Casc Setpt Enabled
42.	Remote Casc Setpt Active
43.	Aux Control Enabled
44.	Aux Control Active
45.	Auxiliary PID in Control
46.	Remote Aux Setpt Enabled
47.	Remote Aux Setpt Active
48.	Valve Limiter in Control
49.	F3 Key Selected
50.	F4 Key Selected
51.	Modbus Command
52.	(Not Used)

Table 6-13. Relay Configuration

Analog Read addresses 3:0106—0117 give the configuration value of the contact inputs, one to twelve in order. The configuration for the contact inputs are defined in the table below.

Value	Description
1.	Generator Breaker
2.	Utility Tie Breaker
3.	Overspeed Test
4.	External Run
5.	Start Permissive
6.	Idle/Rated
7.	Halt/Continue Auto Start Sequence
8.	Override MPU Fault
9.	Select On-Line Dynamics
10.	Local/Remote
11.	Remote Speed Setpt Enable
12.	Sync Enable
13.	(Not Used)
14.	Freq. Control Arm/Disarm
15.	Casc Setpt Raise
16.	Casc Setpt Lower
17.	Casc Control Enable
18.	Remote Casc Setpt Enable
19.	Aux Setpt Raise
20.	Aux Setpt Lower
21.	Aux Control Enable
22.	Remote Aux Setpt Enable
23.	Valve Limiter Open
24.	Valve Limiter Close
25.	External Trip 2
26.	External Trip 3
27.	External Trip 4
28.	External Trip 5
30.	Controlled Shutdown (Manual)
31.	(Not Used)

Table 6-14. Contact Input Configurations

Analog Read addresses 3:0118-0119 give the configuration value of the Aux units and the Cascade units, in order. The configuration for the units are defined in the table below.

Value	Description
1.	psi
2.	kPa
3.	MW
4.	KW
5.	degF
6.	degC
7.	t/h
8.	k#/hr
9.	#/hr
10.	kg/cm ²
11.	bar
12.	atm
13.	(none)

Table 6-15. Units Configuration

Specific Address Information

Entering Setpoint from Modbus

- The setpoint for the Speed, Cascade and Auxiliary can be entered from the Modbus. When the setpoint is entered for any of these functions the setpoint will not move to the entered setpoint instantly, but the setpoint will move towards the entered setpoint at the entered rate defined for the function in the program mode. This functions the same as entering the setpoint from the front panel of the control.
- There is feedback provided to let the operator know what value was entered. This value will not change until a new value is entered from the Modbus. The addresses, 3:0060-:0062, are for speed, cascade, and auxiliary respectively. When the a new value is entered from the Modbus, the setpoint will move to the new value. If the entered setpoint that is the same as the feedback, the operator can use a go to the setpoint command instead of entering the setpoint again. This command needs to be used when the setpoint to be entered is the same as the feedback.

Modbus Scale Factors

Modbus has two limitations:

- only integers can be sent across
- the value is limited between -32767 and 32767

These limitations can be overcome by scaling the value before it is sent across the Modbus. The default scale factor for the analog values is 1. The scale factor can be changed in the service mode between 1 and 100. The following input and setpoint values that are sent across the Modbus have independent scale factors: Casc (3:0030), Aux (3:0037), FSP (3:0041), KW (3:0045), and Sync/Load Share (3:0043). These scaled parameters and their scale factor are available through the Modbus. Values that require a decimal point must be multiplied by the scale factor (10 or 100) prior to being sent across the Modbus. The value sent must then be divided by the scale factor in the Master.

The Scale Factor adjusts all associated analog reads and writes accordingly. For example, the Cascade Scale Factor adjusts the cascade input and setpoint analog read values as well as the Entered Setpt analog write value.

For example, if the Cascade setpoint of 60.15 needs to be sent across the Modbus and have two decimal places, the Cascade Scale Factor would be set to 100 in the Service Mode. This will change the value so that the decimal places can be sent across the Modbus communications link ($60.15 * 100 = 6015$). After the value is sent across the Modbus, it must be rescaled in the Master to the original value ($6015/100 = 60.15$). A Directly Entered Cascade Setpoint (4:0002) of 61.5 would be sent across the link as 6150 and the 505 automatically divides the value by the Casc Scale Factor and uses the value of 61.5 as the setpoint desired.

Modbus Percentage

Some of the analog read addresses have percentages sent across. The formula used in the percentage calculation is $(\text{actual}/\text{max}) * 100$. The percentage is multiplied by 100 before being sent across the Modbus to provide up to 2 decimal places, if desired

Modbus Emergency Shutdown

Two different types of shutdown commands (emergency and controlled) can be issued through Modbus. The Emergency Shutdown command instantly takes the speed setpoint and actuator current to zero. Optionally the 505 can be configured to ignore this Emergency Shutdown command if it is desired to not allow the unit to be tripped through Modbus.

To avoid an inadvertent trip, the emergency shutdown command from Modbus can be configured to require a two step process before a shutdown command is issued. When the shutdown is a two step process Boolean write address 0001 starts the shutdown process. An "ESD ACKN ENABLE" feedback (1:0065) is given and an acknowledge on address 0002 has to be given within five seconds for the control to issue a shutdown command.

See Volume 2 for Service mode tunables.

For More Modbus Information

Detailed information on the Modbus protocol is presented in "Reference Guide PI-MBUS-300" published by AEC Corp./Modicon Inc., formerly Gould Inc. To implement your own source code, you must register with Modicon. Registration includes purchasing document PI-MBUS-303 and signing a non-disclosure agreement. You can register to use Modbus at your nearest Modicon field office. To find the office nearest you, contact Modicon Technical Support at 1-800-468-5342.

Chapter 7.

Service Options

Product Service Options

The following factory options are available for servicing Woodward equipment, based on the standard Woodward Product and Service Warranty (5-01-1205) that is in effect at the time the product is purchased from Woodward or the service is performed:

- Replacement/Exchange (24-hour service)
- Flat Rate Repair
- Flat Rate Remanufacture

If you are experiencing problems with installation or unsatisfactory performance of an installed system, the following options are available:

- Consult the troubleshooting guide in the manual.
- Contact Woodward technical assistance (see “How to Contact Woodward” later in this chapter) and discuss your problem. In most cases, your problem can be resolved over the phone. If not, you can select which course of action you wish to pursue based on the available services listed in this section.

Replacement/Exchange

Replacement/Exchange is a premium program designed for the user who is in need of immediate service. It allows you to request and receive a like-new replacement unit in minimum time (usually within 24 hours of the request), providing a suitable unit is available at the time of the request, thereby minimizing costly downtime. This is also a flat rate structured program and includes the full standard Woodward product warranty (Woodward Product and Service Warranty 5-01-1205).

This option allows you to call in the event of an unexpected outage, or in advance of a scheduled outage, to request a replacement control unit. If the unit is available at the time of the call, it can usually be shipped out within 24 hours. You replace your field control unit with the like-new replacement and return the field unit to the Woodward facility as explained below (see “Returning Equipment for Repair” later in this chapter).

Charges for the Replacement/Exchange service are based on a flat rate plus shipping expenses. You are invoiced the flat rate replacement/exchange charge plus a core charge at the time the replacement unit is shipped. If the core (field unit) is returned to Woodward within 60 days, Woodward will issue a credit for the core charge. [The core charge is the average difference between the flat rate replacement/exchange charge and the current list price of a new unit.]

Return Shipment Authorization Label. To ensure prompt receipt of the core, and avoid additional charges, the package must be properly marked. A return authorization label is included with every Replacement/Exchange unit that leaves Woodward. The core should be repackaged and the return authorization label affixed to the outside of the package. Without the authorization label, receipt of the returned core could be delayed and cause additional charges to be applied.

Flat Rate Repair

Flat Rate Repair is available for the majority of standard products in the field. This program offers you repair service for your products with the advantage of knowing in advance what the cost will be. All repair work carries the standard Woodward service warranty (Woodward Product and Service Warranty 5-01-1205) on replaced parts and labor.

Flat Rate Remanufacture

Flat Rate Remanufacture is very similar to the Flat Rate Repair option with the exception that the unit will be returned to you in “like-new” condition and carry with it the full standard Woodward product warranty (Woodward Product and Service Warranty 5-01-1205). This option is applicable to mechanical products only.

Returning Equipment for Repair

If a control (or any part of an electronic control) is to be returned to Woodward for repair, please contact Woodward in advance to obtain a Return Authorization Number. When shipping the item(s), attach a tag with the following information:

- name and location where the control is installed;
- name and phone number of contact person;
- complete Woodward part number(s) and serial number(s);
- description of the problem;
- instructions describing the desired type of repair.



CAUTION

To prevent damage to electronic components caused by improper handling, read and observe the precautions in Woodward manual 82715, *Guide for Handling and Protection of Electronic Controls, Printed Circuit Boards, and Modules*.

Packing a Control

Use the following materials when returning a complete control:

- protective caps on any connectors;
- antistatic protective bags on all electronic modules;
- packing materials that will not damage the surface of the unit;
- at least 100 mm (4 inches) of tightly packed, industry-approved packing material;
- a packing carton with double walls;
- a strong tape around the outside of the carton for increased strength.

Return Authorization Number

When returning equipment to Woodward, please telephone and ask for the Customer Service Department [1 (800) 523-2831 in North America or +1 (970) 482-5811]. They will help expedite the processing of your order through our distributors or local service facility. To expedite the repair process, contact Woodward in advance to obtain a Return Authorization Number, and arrange for issue of a purchase order for the item(s) to be repaired. No work can be started until a purchase order is received.



NOTE

We highly recommend that you make arrangement in advance for return shipments. Contact a Woodward customer service representative at 1 (800) 523-2831 in North America or +1 (970) 482-5811 for instructions and for a Return Authorization Number.

Replacement Parts

When ordering replacement parts for controls, include the following information:

- the part number(s) (XXXX-XXXX) that is on the enclosure nameplate;
- the unit serial number, which is also on the nameplate.

How to Contact Woodward

In North America use the following address when shipping or corresponding:

Woodward Governor Company
PO Box 1519
1000 East Drake Rd
Fort Collins CO 80522-1519, USA

Telephone—+1 (970) 482-5811 (24 hours a day)
Toll-free Phone (in North America)—1 (800) 523-2831
Fax—+1 (970) 498-3058

For assistance outside North America, call one of the following international Woodward facilities to obtain the address and phone number of the facility nearest your location where you will be able to get information and service.

<u>Facility</u>	<u>Phone Number</u>
Brazil	+55 (19) 3708 4800
India	+91 (129) 230 7111
Japan	+81 (476) 93-4661
The Netherlands	+31 (23) 5661111

You can also contact the Woodward Customer Service Department or consult our worldwide directory on Woodward's website (www.woodward.com) for the name of your nearest Woodward distributor or service facility.

Engineering Services

Woodward Industrial Controls Engineering Services offers the following after-sales support for Woodward products. For these services, you can contact us by telephone, by email, or through the Woodward website.

- Technical Support
- Product Training
- Field Service

Contact information:

Telephone—+1 (970) 482-5811

Toll-free Phone (in North America)—1 (800) 523-2831

Email—icinfo@woodward.com

Website—www.woodward.com

Technical Support is available through our many worldwide locations or our authorized distributors, depending upon the product. This service can assist you with technical questions or problem solving during normal business hours. Emergency assistance is also available during non-business hours by phoning our toll-free number and stating the urgency of your problem. For technical support, please contact us via telephone, email us, or use our website and reference **Customer Services** and then **Technical Support**.

Product Training is available at many of our worldwide locations (standard classes). We also offer customized classes, which can be tailored to your needs and can be held at one of our locations or at your site. This training, conducted by experienced personnel, will assure that you will be able to maintain system reliability and availability. For information concerning training, please contact us via telephone, email us, or use our website and reference **Customer Services** and then **Product Training**.

Field Service engineering on-site support is available, depending on the product and location, from one of our many worldwide locations or from one of our authorized distributors. The field engineers are experienced both on Woodward products as well as on much of the non-Woodward equipment with which our products interface. For field service engineering assistance, please contact us via telephone, email us, or use our website and reference **Customer Services** and then **Technical Support**.

Technical Assistance

If you need to telephone for technical assistance, you will need to provide the following information. Please write it down here before phoning:

General

Your Name _____
 Site Location _____
 Phone Number _____
 Fax Number _____

Prime Mover Information

Engine/Turbine Model Number _____
 Manufacturer _____
 Number of Cylinders (if applicable) _____
 Type of Fuel (gas, gaseous, steam, etc) _____
 Rating _____
 Application _____

Control/Governor Information

Please list all Woodward governors, actuators, and electronic controls in your system:

Woodward Part Number and Revision Letter _____
 Control Description or Governor Type _____
 Serial Number _____

Woodward Part Number and Revision Letter _____
 Control Description or Governor Type _____
 Serial Number _____

Woodward Part Number and Revision Letter _____
 Control Description or Governor Type _____
 Serial Number _____

If you have an electronic or programmable control, please have the adjustment setting positions or the menu settings written down and with you at the time of the call.

Appendix.

505 Program Mode Worksheets

Governor Serial Number _____

Application _____

Date _____

For details on individual settings, refer to Chapter 4.

TURBINE START

Manual Start	YES	NO
Automatic Start	YES	NO
Semiautomatic Start	YES	NO
Rate to Min (rpm/Sec)		rpm/sec
Valve Lmtr Rate (%/Sec)		%/sec
Use Idle/Rated?	YES	NO
Idle Setpt (rpm)		rpm
Rated Setpt (rpm)		rpm
Idle/Rtd Rate (rpm/sec)		rpm/sec
Use Auto Start Sequence	YES	NO
Cold Start = (> xx Hrs)		HRS
Hot Start = (< xx Hrs)		HRS
Low Idle Setpt (rpm)		rpm
Low Idle Delay (Cold)		MIN
Low Idle Delay (Hot)		MIN
Rate to Hi Idle (Cold)		rpm/sec
Rate to Hi Idle (Hot)		rpm/sec
High Idle Setpt (rpm)		rpm
High Idle Delay (Cold)		MIN
High Idle Delay (Hot)		MIN
Rate to Rated (Cold)		rpm/sec
Rate to Rated (Hot)		rpm/sec
Rated Setpt (rpm)		rpm
Auto Halt at Idle Setpts	YES	NO
Ext Trips in Trip Relay	YES	NO
Reset Clears Trip Output	YES	NO

SPEED CONTROL

Teeth Seen by MPU		
Gear Ratio 1 :		
Failed Speed Level(rpm)		rpm
Use Speed Input #2?	YES	NO
Failed Speed Level(rpm)		rpm
Off-Line Prop Gain		%
Off-Line Int Gain		rps
Off-Line Deriv Ratio		%
On-Line Prop Gain		%
On-Line Int Gain		rps
On-Line Deriv Ratio		%

SPEED SETPOINT VALUES

Overspeed Test Lmt (rpm)		rpm
Overspeed Trip (rpm)		rpm
Max Governor Speed (rpm)		rpm
Min Governor Speed (rpm)		rpm
Setpt Slow Rate(rpm/sec)		rpm/sec
Use Remote Speed Setpt ?	YES	NO
Rmt Spd Setpt Max Rate		rpm/sec
Use Critical Speeds?	YES	NO
Critical Speed Rate		rpm/sec
Critical Speed 1 Max		rpm
Critical Speed 1 Min		rpm
Use Critical Band 2 ?	YES	NO
Critical Speed 2 Max		rpm
Critical Speed 2 Min		rpm

OPERATING PARAMETERS

Generator Application?	YES	NO
Use Gen Brkr Open Trip ?	YES	NO
Use Tie Brkr Open Trip ?	YES	NO
Use KW Droop?	YES	NO
KW Max Load		KW
Droop (%)		%
Rated Spd Setpt		rpm
Use Freq Arm/Disarm ?	YES	NO
Use Local/Remote	YES	NO

DRIVER CONFIGURATION

Act #1 is 4-20 mA?	YES	NO
Invert Driver Outputs ?	YES	NO
Use Act 1 Flt Shutdown	YES	NO
Act #1 Dither		%
Use Actuator #2?	YES	NO
Act #2 is 4-20 mA?	YES	NO
Act #2 Offset (%)		%
Use Act 2 Flt Shutdown	YES	NO
Act #2 Dither (%)		%
Use Act #2 as Readout?	YES	NO
Act #2 Readout is:		%
Readout 4 mA Value		Units
Readout 20 mA Value		Units

ANALOG INPUTS

Analog Input # 1 Function	
Input 1 4 mA Value	Units
Input 1 20 mA Value	Units
Analog Input # 2 Function	
Input 2 4 mA Value	Units
Input 2 20 mA Value	Units
Analog Input # 3 Function	
Input 3 4 mA Value	Units
Input 3 20 mA Value	Units
Analog Input # 4 Function	
Input 4 4 mA Value	Units
Input 4 20 mA Value	Units
Analog Input # 5 Function	
Input 5 4 mA Value	Units
Input 5 20 mA Value	Units
Analog Input # 6 Function	
Input 6 4 mA Value	Units
Input 6 20 mA Value	Units

CONTACT INPUTS

Contact Input 1 Function	
Contact Input 2 Function	
Contact Input 3 Function	
Contact Input 4 Function	
Contact Input 5 Function	
Contact Input 6 Function	
Contact Input 7 Function	
Contact Input 8 Function	
Contact Input 9 Function	
Contact Input 10 Fctn	
Contact Input 11 Fctn	
Contact Input 12 Fctn	

FUNCTION KEYS

F3 Key Performs	
Blink when not Active?	YES NO
F4 Key Performs	
Blink when not Active?	YES NO

AUXILIARY CONTROL

Use Auxiliary Control ?	YES	NO
Lost Aux Input Shutdown?	YES	NO
Use KW Input ?	YES	NO
Invert Aux ?	YES	NO
Min Aux Setpt		Units
Max Aux Setpt		Units
Aux Setpt Rate units/sec		Units/sec
Use Aux Enable?	YES	NO
Setpt Initial Value		Units
Aux Droop		%
Aux PID Prop Gain		%
Aux PID Integral Gain		rps
Aux Derivative Ratio		%
Tiebrkr Open Aux Disable	YES	NO
Genbrkr Open Aux Disable	YES	NO
Use Remote Aux Setting	YES	NO
Remote Aux Max Rate		Units/sec
Aux Units of Measure		

CASCADE CONTROL

Use Cascade Control?	YES	NO
Invert Cascade ?	YES	NO
Min Cascade Setpt		Units
Max Cascade Setpt		Units
Casc Setpt Rate (/sec)		Units/sec
Use Setpoint Tracking ?	YES	NO
Setpt Initial Value		Units
Speed Setpt Lower Limit		rpm
Speed Setpt Upper Limit		rpm
Max Speed Rate(rpm/sec)		rpm/Sec
Cascade Droop		%
Casc PID Prop Gain		%
Casc PID Integral Gain		rps
Casc Derivative Ratio		%
Use Remote Casc Setting	YES	NO
Remote Casc Max Rate		Units/sec
Casc Units of Measure		

READOUTS

Analog Readout 1 Is	
Readout 1 4 mA Value	Units
Readout 1 20 mA Value	Units
Analog Readout 2 Is	
Readout 2 4 mA Value	Units
Readout 2 20 mA Value	Units
Analog Readout 3 Is	
Readout 3 4 mA Value	Units
Readout 3 20 mA Value	Units
Analog Readout 4 Is	
Readout 4 4 mA Value	Units
Readout 4 20 mA Value	Units
Analog Readout 5 Is	
Readout 5 4 mA Value	Units
Readout 5 20 mA Value	Units
Analog Readout 6 Is	
Readout 6 4 mA Value	Units
Readout 6 20 mA Value	Units

RELAYS

Use Relay #1?	YES	NO
Relay # 1 is Level Switch?	YES	NO
Relay 1 Is Level Sw For		
Relay 1 ON Level		Units
Relay 1 OFF Level		Units
Relay 1 Energizes On		
Use Relay # 2?	YES	NO
Relay # 2 is Level Switch?	YES	NO
Relay 2 Is Level Sw For		
Relay 2 On Level		Units
Relay 2 Off Level		Units
Relay 2 Energizes On		
Use Relay # 3?	YES	NO
Relay # 3 is Level Switch?	YES	NO
Rly 3 Is Level Sw For		
Relay 3 On Level		Units
Relay 3 Off Level		Units
Relay 3 Energizes On		
Use Relay # 4?	YES	NO
Relay # 4 is Level Switch?	YES	NO
Rly 4 Is Level Sw For		
Relay 4 On Level		Units
Relay 4 Off Level		Units
Relay 4 Energizes On		
Use Relay # 5?	YES	NO
Relay # 5 is Level Switch?	YES	NO
Rly 5 Is Level Sw For		
Relay 5 On Level		Units
Relay 5 Off Level		Units
Relay 5 Energizes On		
Use Relay # 6?	YES	NO
Relay # 6 is Level Switch?	YES	NO
Rly 6 Is Level Sw For		
Relay 6 On Level		Units
Relay 6 Off Level		Units
Relay 6 Energizes On		

COMMUNICATIONS

Use Communications ?	YES	NO
Use Modbus Port 1?	YES	NO
Mode Ascii=1 Rtu=2		
Modbus Device #		
Port #1 Driver		
Port #1 Baud Rate		
Port #1 Stop Bits		
Port #1 Parity		
Use Modbus Port 2?	YES	NO
Mode Ascii=1 Rtu=2		
Modbus Device #		
Port #2 Driver		
Port #2 Baud Rate		
Port #2 Stop Bits		
Port #2Parity		

DECLARATION OF CONFORMITY

According to EN 45014

Manufacturer's Name: WOODWARD GOVERNOR COMPANY (WGC)
Industrial Controls Group

Manufacturer's Address: 1000 E. Drake Rd.
Fort Collins, CO, USA, 80525

Model Name(s)/Number(s): 505 Control: 18-32 Vdc (9907-164 and similar)
505E Control: 18-32 Vdc (9907-167 and similar)
505H Control: 18-32 Vdc (9907-117 and similar)

Conformance to Directive(s): 89/336/EEC COUNCIL DIRECTIVE of 03 May 1989 on the approximation of the laws of the Member States relating to electromagnetic compatibility.

94/9/EC COUNCIL DIRECTIVE of 23 March 1994 on the approximation of the laws of the Member States concerning equipment and protective systems intended for use in potentially explosive atmospheres

Applicable Standards: EN61000-6-2, 1999: EMC Generic Standards - Immunity for Industrial Environments
EN50081-2, August 1993: EMC Generic Emissions Standard, Part 2: Industrial Environment
EN50082-2, March 1995: EMC Generic Immunity Standard, Part 2: Industrial Environment
EN 60079-15, 2003: Electrical apparatus for potentially explosive atmospheres - Type of protection 'n'

We, the undersigned, hereby declare that the equipment specified above conforms to the above Directive(s).

MANUFACTURER

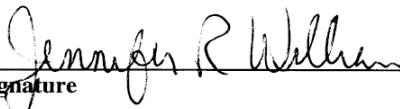

Signature

Jennifer Williams

Full Name

Engineering Manager

Position

WGC, Fort Collins, CO, USA

Place

7-9-04

Date

We appreciate your comments about the content of our publications.

Send comments to: icinfo@woodward.com

Please include the manual number from the front cover of this publication.



PO Box 1519, Fort Collins CO 80522-1519, USA
1000 East Drake Road, Fort Collins CO 80525, USA
Phone +1 (970) 482-5811 • Fax +1 (970) 498-3058

Email and Website—www.woodward.com

Woodward has company-owned plants, subsidiaries, and branches,
as well as authorized distributors and other authorized service and sales facilities throughout the world.

Complete address / phone / fax / email information for all locations is available on our website.